

## LSI Logic MegaRAID<sup>®</sup> SCSI 320-1 Controller

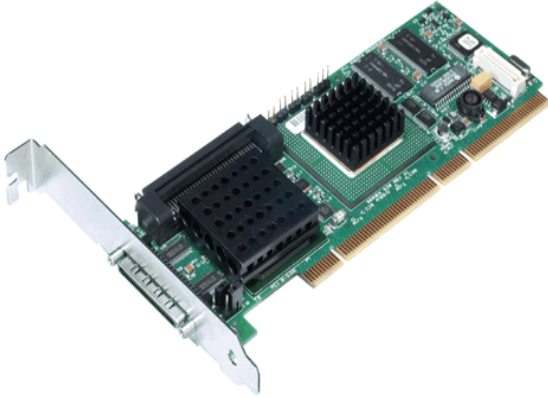

Thank you for purchasing the MegaRAID SCSI 320-1 Controller. Please take a few minutes to read this *Quick Hardware Setup Guide* before you install the MegaRAID controller. If you need more information about any topic covered in this guide, please refer to the other documents on your Driver and Documentation CD.

### Contents of Driver and Documentation CD

The Driver and Documentation CD is packaged with the MegaRAID SCSI 320-1 Controller. The CD contains utility programs, device drivers for various operating systems, and the following documentation:

- *MegaRAID SCSI 320-1 Hardware Guide*
- *MegaRAID Configuration Software Guide*
- *MegaRAID Operating System Driver Installation Guide*
- Software license agreement and warranty registration card

### Technical Support

If you need help installing, configuring, or running the MegaRAID SCSI 320-1 Controller, contact LSI Logic Technical Support:

**Phone Support:** 678-728-1250

**Web Site:** <http://megaraid.lsillogic.com/support/index.html>

**Email:** [MegaRAIDsupport@lsil.com](mailto:MegaRAIDsupport@lsil.com)

### MegaRAID Controller Installation

**Caution:** Make a backup of your data before you change your system configuration. Otherwise you may lose data.

Follow these steps to install the MegaRAID SCSI 320-1 Controller. Each step is explained more fully in the following text:

| Step | Action  |
|------|---|
| 1    | Unpack the MegaRAID SCSI 320-1 Controller.                          |
| 2    | Turn off the computer, remove the power cord, and remove the cover. |
| 3    | Check the MegaRAID controller jumper settings.                      |
| 4    | Install the MegaRAID controller.                                    |
| 5    | Connect the SCSI devices to the MegaRAID controller.                |
| 6    | Set the target IDs for the SCSI devices.                            |
| 7    | Set SCSI termination.   |
| 8    | Replace the computer cover and turn the power on.                   |

| Step | Action                                       |
|------|--|
| 9    | Run the MegaRAID BIOS Configuration Utility. |
| 10   | Install the operating system driver.         |

### Step 1: Unpack MegaRAID Controller

Unpack and install the MegaRAID SCSI 320-1 Controller in a static-free environment. Remove the MegaRAID controller from the anti-static bag and inspect it for damage. If it appears to be damaged, or if the Driver and Documentation CD is missing, contact LSI Logic or your MegaRAID OEM support representative.

### Step 2: Prepare Computer

Turn off the computer and remove the power cord from the back of the power supply. Remove the cover from the chassis. *Make sure the computer is disconnected from the power and from any networks before installing the controller card.*

### Step 3: Check MegaRAID Controller Jumpers

Make sure the jumper settings on the MegaRAID controller are correct. The jumpers are set at the factory, and you probably do not need to change them. The following table lists the jumpers and connectors on the RAID controller.

| Item | Description  | Type             |
|------|--|------------------|
| J1   | Internal high-density SCSI connector.  | 68-pin connector |
| J2   | Dirty cache LED: This can be connected to an LED on the computer enclosure. The LED will be lit when data in the cache has not yet been written to the storage device. | 2-pin header     |
| J3   | Clears EPROM configuration data.   | 2-pin header     |
| J4   | Enables or disables the MegaRAID onboard BIOS. Leave the BIOS enabled (no jumper).   | 2-pin header     |
| J5   | SCSI activity indicator: this can be connected to the hard disk LED on the computer case to show SCSI bus activity.  | 2-pin header     |
| J6   | Serial port. For test purposes only.   | 3-pin connector  |
| J7   | External Very High-density SCSI connector.   | 68-pin connector |
| J8   | Battery backup board connector.  | 40-pin connector |
| J9   | SCSI bus termination power. Leave at the default setting (jumper installed) to allow the PCI bus to provide termination power.   | 2-pin header     |
| J10  | SCSI Termination Control: Leave at the default setting (jumper on pins 1 and 2) to allow the MegaRAID controller to automatically set its own SCSI termination.        | 3-pin header     |

# Quick Hardware Setup Guide

The following diagram shows the location of the jumpers and connectors on the MegaRAID SCSI 320-1 Controller.

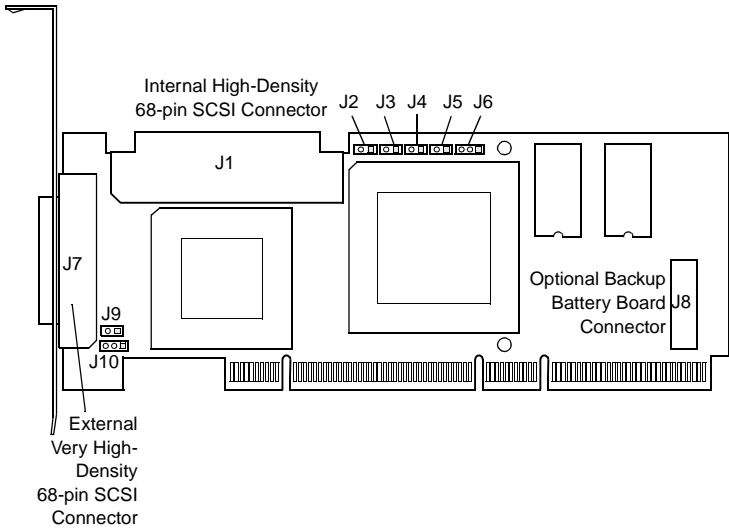

### Step 4: Install the MegaRAID SCSI 320-1 Controller

Install the MegaRAID SCSI 320-1 Controller in a 3.3 V or 5 V PCI slot, as shown below. Press down gently, but firmly, to make sure that the card is properly seated in the slot. The bottom edge of the controller card must be flush with the slot. Attach the MegaRAID controller to the computer chassis with the bracket screw.

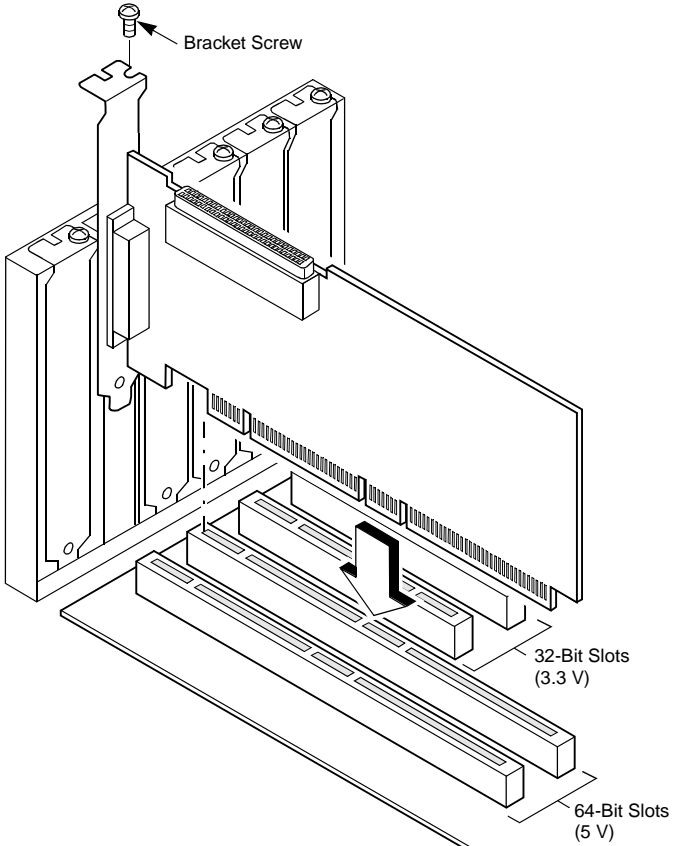

### Step 5: Connect SCSI Devices to MegaRAID Controller

Connect SCSI devices to the internal high-density 68-pin SCSI connector (J1) and/or the external very high-density 68-pin SCSI connector (J7). To achieve maximum data throughput, use only Ultra320 SCSI devices. The MegaRAID SCSI 320-1 Controller supports up to 15 Ultra320 devices at a maximum SCSI

bus cable length of 12 m. You can also connect Ultra160 and Ultra2 SCSI devices. The *MegaRAID SCSI 320-1 Hardware Guide* lists the maximum number of devices and maximum cable length for each kind of SCSI device.

Disable SCSI termination on all devices that are not connected at the end of the SCSI bus. Use only high-quality ribbon SCSI cables for internal devices and high-quality round SCSI cables for external devices.

### Step 6: Set Target IDs for SCSI Devices

Each connected SCSI device must have a unique Target ID (TID), ranging from 0 to 15 for 16-bit devices. Note that under DOS ASPI, SCSI devices are limited to SCSI IDs 1 to 6. The MegaRAID SCSI 320-1 Controller is automatically assigned TID 7, which has the highest priority. Check all SCSI devices to make sure that no two devices are set to the same TID. Change the TIDs as needed. See the SCSI device documentation if you are not sure how to do this.

### Step 7: Set SCSI Termination

The SCSI bus, which consists of connected SCSI cables and SCSI devices, is an electrical transmission line that must be terminated properly to minimize signal reflections and prevent data loss. Disk enclosures normally handle termination for the SCSI devices in the enclosure. Refer to your enclosure documentation for more information.

SCSI termination must be set at each end of the SCSI bus, as shown in the following figure. In this example, only internal SCSI devices are connected to the MegaRAID controller. The MegaRAID controller automatically terminates its end of the SCSI bus if only internal devices or only external devices are connected to the SCSI bus. It automatically disables termination if both internal and external devices are connected to the bus, because the MegaRAID controller is then in the "middle" of the bus.

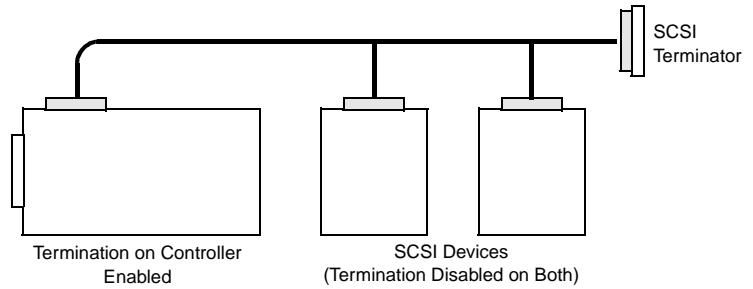

For a disk array, set SCSI bus termination so that removing or adding a SCSI device does not disturb termination. To do this, connect the MegaRAID SCSI 320-1 Controller to one end of the SCSI cable and connect a SCSI terminator module at the other end of the cable. Attach SCSI devices to the connectors between the two ends, and disable termination on them. The following example shows an external drive enclosure with seven SCSI drives. Termination is enabled at the end of the cable nearest the "last" SCSI drive, which is assigned SCSI ID6.

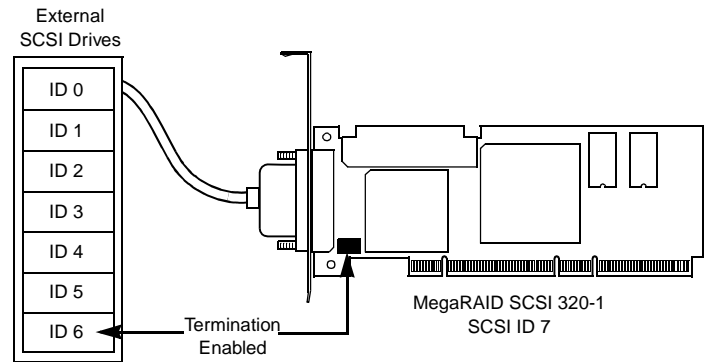

# Quick Hardware Setup Guide

## Step 8: Power Up the Computer

Replace the computer cover and connect the power cords to all the SCSI devices and to the computer itself. Turn on the power to all devices. Be sure the SCSI devices are powered up before the computer or at the same time as the computer. Otherwise, the computer may not recognize the SCSI devices.

Observe the messages that appear during the boot process, until you see the message:

Press <Ctrl><M> to run MegaRAID SCSI 320-1 BIOS Configuration Utility

## Step 9: Run MegaRAID BIOS Configuration Utility

When the "Press <Ctrl><M>" message appears on the screen, press <Ctrl><M> immediately to run the MegaRAID BIOS Configuration Utility. See the *MegaRAID Configuration Software Guide* on the Driver and Documentation CD for information about how to run and use this program.

## Step 10: Install the Operating System Driver

The MegaRAID controller can operate under MS-DOS® or any DOS-compatible operating system using the standard AT BIOS INT 13h Hard Disk Drive interface. To operate with other operating systems, you must install software drivers. The Driver and Documentation CD includes drivers for the following operating systems:

- MS-DOS version 6.xx or later
- Microsoft Windows NT v4.0, Windows 2000, Windows XP, and Windows .NET
- Novell NetWare 5.1 and 6.0
- Red Hat Linux 7.2 and 7.3

## Supported RAID Levels

The MegaRAID SCSI 320-1 Controller supports disk arrays using the following RAID levels:

- **RAID 0 (Data striping):** Data is striped across all disks in the array, enabling very fast data throughput. There is no data redundancy. All data is lost if any disk fails. (1-15 disk drives)
- **RAID 1 (Disk mirroring):** Data is written simultaneously to two disks, providing complete data redundancy in case one disk fails. The array capacity is half of total disk space. (2 disk drives)
- **RAID 5 (Disk striping with distributed parity):** Data is striped across all disks in the array. Part of the capacity of each disk is used to store parity information that is used to reconstruct data if a disk fails. Provides good data throughput for applications with high read request rates. (3 to 15 disk drives)
- **RAID 10 (RAID 1 and RAID 0 in spanned arrays):** Uses mirrored pairs of disks to provide complete data redundancy. Provides high data throughput rates. (4 to 14 disk drives)
- **RAID 50 (RAID 5 and RAID 0 in spanned arrays):** Uses both parity and disk striping across multiple disks to provide complete data redundancy. Provides high data throughput rates. (6 to 15 disk drives)



You can find a list of LSI Logic's U.S. distributors, international distributors, sales offices, and design resource centers on the LSI Logic web site at:  
[http://www.lsillogic.com/contacts/na\\_salesoffices.html](http://www.lsillogic.com/contacts/na_salesoffices.html)