

Manual for

Acer n20 Handheld

COPYRIGHT

Copyright © 2002 Acer Inc. or its subsidiaries
All Rights Reserved. Printed in Taiwan.

Acer n20 Handheld Manual
Original issue: August 2002

Acer and the Acer logo are registered trademarks of Acer Inc.

Microsoft, ActiveSync, Outlook, Pocket Outlook, Windows, Windows NT, and the Windows logo are either registered trademarks or trademarks of Microsoft Corporation in the United States and/or other countries. Microsoft products are licensed to OEMs by Microsoft Licensing, Inc., a wholly owned subsidiary of Microsoft Corporation.

Other company's product names or trademarks are used herein for identification purpose only and belong to their respective companies.

Changes may be made periodically to the information in this publication without obligation to notify any person of such revision or changes. Such changes will be incorporated in new editions of this Manual or supplementary documents and publications.

No part of this publication may be reproduced, stored in a retrieval system, or transmitted, in any form or by any means, electronic, mechanical, photocopy, recording, or otherwise, without the prior written permission of Acer Inc.

DISCLAIMER AND LIMITATION OF LIABILITY

Acer and its subsidiaries makes no representations or warranties, either expressed or implied, with respect to the contents hereof and specifically disclaims the implied warranties of merchantability or fitness for a particular purpose. Acer and its subsidiaries assume no responsibility for any damage or loss resulting from the use of this Acer n20 Handheld Manual.

NOTES

Record the serial number, purchase date, and place of purchase information in the space provided below. The serial number is recorded on the label affixed to your Acer n20. All correspondence concerning your unit should include the serial number and purchase information.

Acer n20 Handheld

S/N: _____

Purchase Date: _____

Place of Purchase: _____

About this Manual

Welcome to the Acer n20 Handheld Manual. This Manual is designed to help you get up and running quickly with your new Acer n20—a Windows® Powered Pocket PC 2002 handheld. It describes all you need to know about how to use your handheld as well as the application programs that come with it.

This Manual will discuss the following topics:

- Acer n20 system tour
- Setup and maintenance procedures
- Viewing and entering data
- Using the application programs bundled with you handheld
- Taking advantage of your handheld's expansion features
- Synchronising data between your handheld and your computer
- Connecting your handheld to a computer, a network, or the Internet
- Personalising your handheld with your own preference settings

This Manual introduces you to the many ways your Acer n20 can help you organise and manage both business and personal information to make your everyday activities a more productive and satisfying experience.

About this Manual

First things first

We would like to thank you for making Acer n20 your choice for your handheld needs. Your new sleek Acer n20 is a multi-functional tool packed with user-friendly features and high-performance applications designed to make organising work-related information and synchronising it with your personal activities a time-efficient task. We hope you enjoy using your Acer n20 as much as we enjoyed creating it for you.

Use your Acer n20 to effectively manage information related to both business and personal tasks.

- Use the Microsoft® Pocket PC 2002 software to perform organising and computing tasks
- Synchronise the information on your computer with the information on your handheld using Microsoft® ActiveSync®
- Get connected to the Internet with the Microsoft® Pocket Internet Explorer
- Create an on-the-go backup file
- Expand your handheld's capabilities using either the built-in *Memory Stick* slot or the optional expansion sleeve
- Beam information to another IR-enabled device
- Communicate using the built-in wireless communication feature (applicable to the Acer n20w model only)
- Customise your handheld based on your personal requirements and preferences

Your guides

To help you use your Acer n20, we have designed a set of guides:

For information on:	Refer to:
Programs on your handheld	This Manual. Bundled in the Acer n20 Handheld Companion CD, it provides online reference for using your Acer n20. The Acer n20 Handheld Help. To view Help, tap  and then Help.
Programs on your handheld	The Acer n20 Handheld Companion CD.
Additional programs that can be installed on your handheld	
Connecting to and synchronising with your computer	The Just for Starters... poster. ActiveSync Help on your computer. To view Help, click Help and then Microsoft ActiveSync Help.

First things first

Package contents

For information on:	Refer to:
Last-minute updates and detailed technical information	The Read Me files. Located in the Microsoft ActiveSync folder on your computer and on the Acer n20 Handheld Companion CD.
Up-to-date information regarding your handheld	http://www.acer.com/

Package contents

Your Acer n20 comes packed in a cardboard box. Carefully unpack the box and remove the contents. If any of the following items are missing or damaged, contact your dealer immediately:

- Acer n20 handheld
- Stylus
- USB cradle
- Battery pack
- AC adapter
- Just for Starters... poster
- Acer n20 Handheld Quick Guide
- Acer n20 Handheld Companion CD
- Acer n20 Handheld Accessories Catalogue
- Warranty Agreement

Optional accessories

To create more variety and expand the capabilities of your Acer n20, you can purchase the following optional accessories.

- Expansion sleeve
- Extra battery pack
- Plug adapter
- USB sync cable
- Earphones with microphone
- 4-in-1 handheld pen
- Colour stylus pack
- Leather cover

Taking care of your Acer n20

This section provides information on the following:

- Proper care and usage of your handheld
- Resetting your handheld

Proper care and usage of your Acer n20

Your Acer n20's rugged and tough construction is designed to provide you with years of reliable and trouble-free service. Observing the following general maintenance procedures will help ensure this:

- 1 Take care not to scratch the screen of your handheld. Keep the screen clean. When working with your handheld, use the supplied stylus or plastic-tipped pens intended for use with touch-sensitive screens. Never use an actual pen or pencil or other sharp object on the screen surface.
- 2 Your handheld is not waterproof and should not be exposed to rain or moisture. Under extreme conditions, water may enter the circuitry through the front panel buttons. In general, treat your handheld as you would a pocket calculator or other small electronic device.
- 3 Take care not to drop your handheld or subject it to any strong impact. Do not place your handheld in your back pocket; if you sit on it, you may damage it.
- 4 Protect your handheld from temperature extremes. For example, do not leave your handheld on the dashboard of a car on a hot day or on a day when temperatures are below the freezing point. Also, keep it away from heaters and other sources of heat.
- 5 Do not use or store your handheld in any location that is extremely dusty, damp or wet.
- 6 Use a soft, damp cloth to clean your handheld. If the surface of the screen becomes soiled, clean it with a soft cloth moistened with diluted window-cleaning solution.

Resetting your Acer n20

You may have to perform a reset if your handheld no longer responds to the buttons on the screen.

Performing a soft reset

A soft reset allows your handheld to get a fresh start, similar to rebooting a computer. All records and entries are retained after a soft reset.

To perform a soft reset:

- Using the tip of your stylus, lightly press the reset button inside the hole on the rear panel of your handheld.



Performing a hard reset

A hard reset will erase all records and entries stored in your handheld. Never perform a hard reset unless a soft reset does not correct your problem. When you perform your next ActiveSync operation, you can restore any data that you previously synchronised to your computer. To perform a hard reset, do the following:

- 1 Detach the battery pack from your handheld.
Refer to "To uninstall the battery pack" on page 9 for instructions.
- 2 Slide up the hard reset switch located on the right side of the battery bay **(a)** then slide it down again **(b)**.

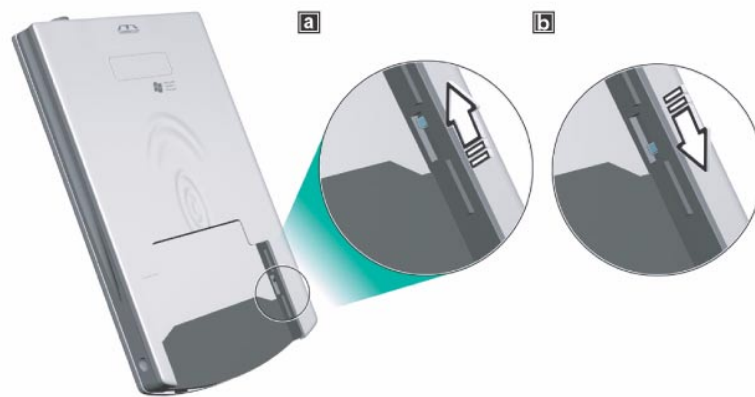

- 3 After resetting your handheld, reinstall the battery pack in its bay.
Refer to "To install the battery pack" on page 8 for instructions.

NOTE: When you perform a hard reset, the current date and time are retained. Formats, preferences, and other settings are restored to their factory default settings.

Locking your Acer n20

Your handheld is not just a financial investment but a wealthy source of personal information, some of which may be confidential so it is only logical to protect it from any unauthorized access. The Security setting gives you the option of assigning a lock password that will be required to access your handheld after a set period of inactivity.

To assign a lock password

- 1 Tap , Settings.
- 2 On the Personal tab, tap Password.
- 3 Select a password option.
 - Simple 4 digit password
 - Strong alphanumeric password
- 4 Define the period of inactivity before the lock password will be required for access.
- 5 Enter a password then retype it to confirm.

For more information, refer to "Password" on page 124.

Contents

About this Manual	iii
First things first	v
Your guides	v
Package contents	vi
Optional accessories	vi
Taking care of your Acer n20	vi
Proper care and usage of your Acer n20	vi
Resetting your Acer n20	vii
Locking your Acer n20	ix
1 Getting started	1
Features summary	1
Performance	1
Display	1
Audio	1
Connectivity	1
Expansion	2
Battery pack	2
Design and ergonomics	2
Acer n20 tour	3
Front view	3
Left view	5
Top view	6
Bottom view	7
Preparing to use your Acer n20	7
Installing the Microsoft® ActiveSync® software	7
Installing the battery pack	8
Connecting the cradle	10
Charging your Acer n20	11
Setting up your Acer n20	12
Performing the first synchronisation process	13
Command interface	14
Hardware buttons and the stylus	14
Today screen	15
Navigation bar and command bar	16
Pop-up menus	17
Notifications	18
2 Entering data in your Acer n20	19
Using the input panel	19
To type with the soft keyboard	20
To use Letter Recognizer	20

To use Block Recognizer	20
To use Transcriber	21
Writing on the screen	21
To write on the screen	22
Drawing on the screen	24
To create a drawing	24
Recording a message	26
To create a recording	26
To play a recording	26
Using My Text	27
To insert a My Text message	27
3 Managing applications and information	29
Opening an application	29
Switching between applications	29
Finding and organising information	31
To use Find	31
To use File Explorer	31
4 Managing Microsoft® Pocket Outlook applications	33
Calendar	33
Scheduling an appointment	34
Creating a meeting request	36
Contacts	36
Creating a contact	37
Finding a contact	38
Tasks	39
Creating a task	40
Notes	42
Creating a note	42
Inbox	43
Synchronising email messages	44
Connecting directly to an email server	44
Using the Message list	45
Composing a message	46
Managing email messages and folders	47
5 Managing Microsoft® Pocket PC 2002 companion programs	49
Pocket Word	49
Creating a new file	49
Entering information	50
Pocket Excel	53
Creating a new workbook	53
Displaying the toolbar	54
Protecting your workbooks	54
MSN® Messenger	55
Setting up an account	56

Working with contacts56
Chatting with contacts56
Microsoft® Windows Media™ Player for Pocket PC®57
Microsoft® Reader for Pocket PC®58
Using Guidebook.58
Getting books on your Acer n2059
Using Library59
Opening a book59
Reading a book59
Using the Reader features60
Removing a book61
6 Using third-party applications	63
RecentDo63
Backup/Restore64
Backup function66
Restore function70
Deleting a file from a storage card74
IA Album LE75
IA Album LE menus.76
Acrobat® Reader® for Pocket PC®85
PocketTV Enterprise Edition.86
Command bar86
Seek/Progress bar87
Status bar.87
Tools menu88
7 Using expansion features	91
<i>Memory Stick</i>91
Inserting a <i>Memory Stick</i>91
Removing a <i>Memory Stick</i>92
Acer Versatile Connector93
Expansion sleeve93
Attaching your Acer n20 to the expansion sleeve94
Using the expansion sleeve95
8 Exchanging and updating data using ActiveSync®	99
9 Getting connected	101
Infrared communication	101
Sending information	101
Receiving information	102
Wireless communication	102
Activating the wireless feature	103
Configuring the wireless settings	103
Configuring the WLAN utility	104
Connecting to the Internet	110

To create a modem connection to an ISP	110
To create an Ethernet connection to an ISP.	111
Connecting to a network	111
To create a modem connection to a network	112
To create an Ethernet connection to a network	112
Starting a connection	112
Ending a connection	112
Connecting directly to an email server	113
Getting help on connecting	113
10 Using Microsoft® Pocket Internet Explorer	115
Mobile Favorites folder	115
Favorite links	115
Mobile favorites.	116
AvantGo channels	117
Signing up for AvantGo	117
Using Pocket Internet Explorer	118
To view mobile favorites and channels	118
To browse the Internet	119
11 Customising your handheld	121
Adjusting handheld settings	121
Personal	122
System	126
Connections	132
Adding and removing programs	134
Adding programs	134
Removing programs	136
Adding a program to the Start menu	136
Index	139

1 Getting started

This chapter will discuss the following topics:

- Feature highlights of your Acer n20
- Acer n20 system tour
- Step-by-step procedures on how to prepare your handheld for use
- Basic concepts in using your Acer n20

Features summary

Performance

- Intel® PXA250 Applications Processor with Intel® XScale™ Technology
- System memory:
 - 64 MB SDRAM for application storage
 - 32 MB Flash ROM for operating system
- Microsoft® Pocket PC 2002 Premium with Microsoft® Outlook 2000

Display

- 3.8" Reflective TFT LCD (Thin Film Transistor Liquid Crystal Display)
- 240 x 320 resolution
- 16-bit or 64K colour support
- Microsoft® ClearType technology for clearer, crisper font display
- MediaQ graphics controller for enhanced graphics performance

Audio

- Embedded AC '97 CODEC with CD-quality stereo output
- Built-in industry-standard 3.5-mm earphone jack
- Built-in microphone

Connectivity

- 19-pin Acer Versatile Connector
- 100-pin expansion connector
- SIR (Standard Infrared) capability
- Wireless communication function using the built-in IEEE 802.11b WLAN (Wireless LAN) adapter (applicable to the Acer n20w model only)

1 Getting started

Features summary

Expansion

- Integrated *Memory Stick* slot
- Acer Versatile Connector
- Expansion sleeve (optional, sold separately)
 - CompactFlash Type II slot
 - PC Card Type II slot
 - Standard USB host connector

Battery pack

- Removable and rechargeable Lithium polymer battery
 - Acer n20 - 1000 mAH capacity battery pack
 - Acer n20w - 2000 mAH capacity battery pack
- Operation time for normal usage
 - Acer n20 - 8 hours
 - Acer n20w - 15 hours

NOTE: Length of battery operation will depend on power consumption which in turn is based on system resources use. For example, constantly using the backlight or using power-demanding applications will shorten the length of battery operation.

- Charging time from empty to full capacity
 - Acer n20 - 4 hours
 - Acer n20w - 8 hours
- Built-in backup battery

Design and ergonomics

- Stylish, light and thin design

Specifications	Acer n20	Acer n20w
Height	12.9 cm	12.9 cm
Width	7.9 cm	7.9 cm
Depth	1.29 cm	1.96 cm
Weight	180g	235g

- User-friendly navigation features
 - Scroll wheel for one-hand operation
 - Directional pad for multi-directional scrolling in various menus and applications
 - Quick buttons to easily launch commonly-used applications
 - Start  button for one-tap access to all available applications
 - Hold switch lets you lock all buttons from being accidentally pressed when handheld is placed in pocket or in a bag.

Acer n20 tour

Front view



No.	Component	Description
1	Power button/ LED indicator	<p>Press to turn on your handheld (LED lights up green) if it is off and returns to the last screen that was displayed, and off if it is on.</p> <p>LED status description.</p> <ul style="list-style-type: none"> Flashing green - Charging handheld Steady green - Charging complete Flashing red - Alarm indicator, email is received
2	Stylus holder	Secures the stylus to your handheld. To use the stylus, remove it from its holder and hold it the same way you hold a pen or pencil.
3	LCD touchscreen	Displays the applications and data stored in your handheld. It is touch-sensitive and responds to the stylus or your finger.
4	Quick button for Today	Displays the Today screen. For more information on this screen, refer to page 15.
5	Quick button for Calendar	Activates the Calendar program. For more information on this program, refer to page 33.

1 Getting started

Acer n20 tour

No.	Component	Description
6	Directional pad	Enables multi-directional scrolling in various menus and applications. Press the center of the pad on to simulate the function of the Enter key.
7	Quick button for Contacts	Activates the Contacts program. For more information on this program, refer to page 36.
8	Quick button for Inbox	Activates the Inbox program. For more information on this program, refer to page 43.
9	Microphone	Inputs audio into your handheld.
10	Internal speaker	Outputs sounds from your handheld.

NOTE:

Refer to "Personal" on page 122 for instructions on how to reassign the hardware buttons to other applications installed on your handheld.

If your handheld is turned off, pressing any Quick button turns on the handheld and opens the program assigned to that button.

Using the backlight

If lighting conditions make it difficult for you to see the information on your handheld, use the backlight to illuminate your screen.

You can change the backlight settings. Refer to "System" on page 126.

To activate the backlight:



- Press the power button and hold it down for about two seconds. Release the button when the backlight turns on.

To turn off the backlight:

- Press the power button and hold it down for two seconds. Release the button when the backlight turns off.

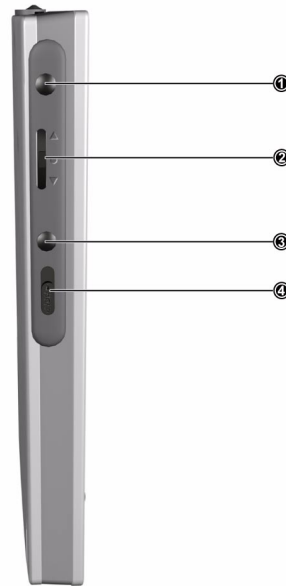
Left view





No.	Component	Description
1	Record button 	Activates the Microsoft® Pocket PC's Record program. For more information on how to use this program, refer to page 26.
2	Scroll wheel ▲ ● ▼	Scroll one page up or down to display the text and other information that extends beyond the area of the LCD touchscreen.
3	Start hardware button 	Hardware button to display the Start menu.
4	Hold switch	Slide to lock all buttons from being accidentally pressed when handheld is placed in pocket or in a bag.

1 Getting started

Acer n20 tour

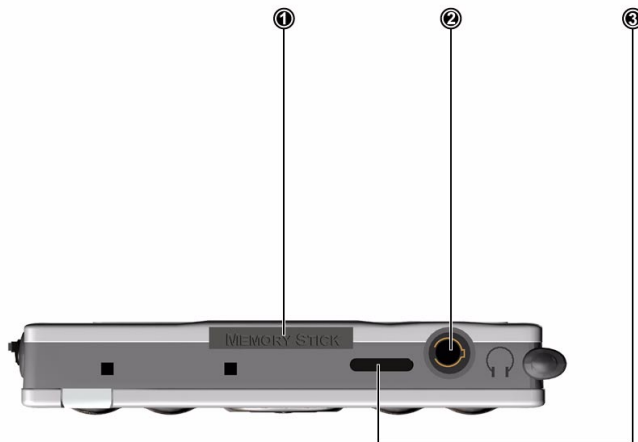
Top view



No.	Component	Description
1	Memory Stick slot 	Accepts a <i>Memory Stick</i> , allowing you to add more memory, install add-on applications or use audio or text files stored in it for use with internal applications. You can also use it to back up data from your handheld.
2	Earphone jack 	Connects to audio line-out devices (earphones/headphones).
3	Infrared (IR) port	Uses infrared technology to transmit and receive data from other IR-enabled devices.

Bottom view

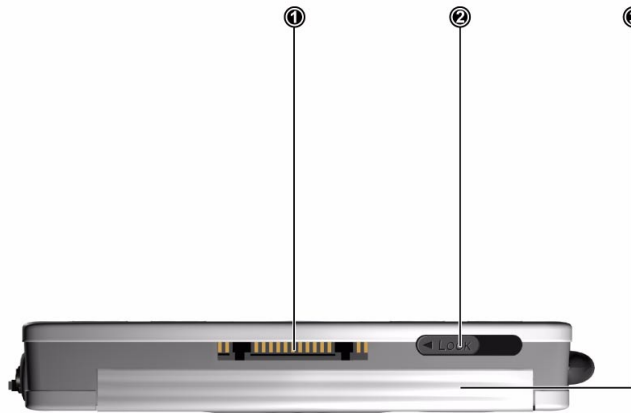

No.	Component	Description
1	Acer Versatile Connector	Connects your handheld to the cradle, which in turn connects to the back of your computer and through the AC adapter to the wall current. This allows you to recharge your handheld and perform an ActiveSync operation. You can also use it to connect peripheral hardware devices, such as an external keyboard, to your handheld.
2	Battery release switch	Unlatch to detach the removable battery pack from its bay.
3	Battery bay	Houses the handheld's battery pack.

Preparing to use your Acer n20

Perform first the following easy setup tasks to begin using your handheld:

- Install the Microsoft® ActiveSync® software in your computer
- Install the battery pack
- Connect the cradle
- Charge your handheld
- Set up your handheld
- Perform the first ActiveSync operation

Installing the Microsoft® ActiveSync® software

The main function of the Microsoft® ActiveSync® software is to synchronise the information on your computer with the information on your handheld. Synchronisation compares the data on your handheld with your computer and updates the information on both locations. This will then served as a backup file in case something happens to your handheld.

1 Getting started

Preparing to use your Acer n20

The following instructions tell you how to install the ActiveSync® software.

Important installation notes

- Before installing ActiveSync, make sure that your handheld cradle is not yet connected to your computer. Connect the cradle only after you have finished installing ActiveSync.
- If you don't have Microsoft® Outlook® 98 installed, please install Microsoft® Outlook® 2000 now.
- It is recommended that users choosing to install Outlook 2000 from this CD do so before installing ActiveSync.
- Do not copy the ActiveSync files to your computer's hard disk. You must use the Acer n20 Handheld Companion CD to place the files in their proper locations and to decompress the files.

To install the Microsoft® ActiveSync® software

- 1 Exit any open programs, including those that run at startup, and disable any virus-scanning software.
- 2 Insert the Acer n20 Handheld Companion CD into the computer's CD-ROM drive. The CD's welcome page appears.
- 3 Click the animated forward icon to go to the next screen.
- 4 Click the Start Here tab on the right side of the screen.
- 5 Read the instructions and installation notes indicated on the Start Here screen.
- 6 Click the buttons on the left pane to install each of the individual applications.
 - Outlook 2000 (recommended)
 - ActiveSync® 3.5

After installation, the ActiveSync icon  will appear on your computer's system tray (on the lower right-hand corner of the screen).

Refer to the ActiveSync software online Help for information on how to use the software. If at any time, you would like to restart this setup program, simply re-insert the CD into the CD-ROM drive.

Installing the battery pack

Your Acer n20 uses a removable and rechargeable Lithium polymer battery pack. Refer to the succeeding section for instructions on how to install the battery pack to your handheld.

To install the battery pack

- 1 Turn the handheld over to access its rear panel.
- 2 Check that the battery release switch is in the Unlock position.
- 3 Slide down the hard reset switch located on the right side of the battery bay.

IMPORTANT: You will only need to slide down the hard reset switch for the initial installation of the battery pack. There is no need to use this switch for subsequent battery pack reinstallation unless you intend to perform a hard reset. For more information on performing a hard reset, refer to page viii.

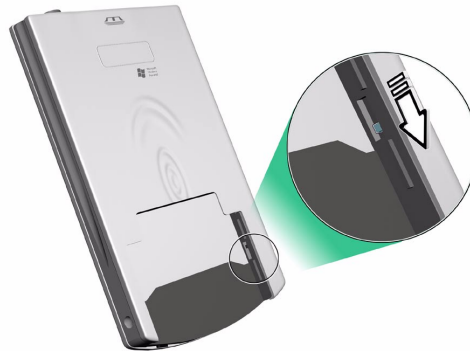

- 4 Insert the battery pack into the battery bay **(a)**, then slide the battery release switch to the Lock position **(b)**.



To uninstall the battery pack

- 1 Turn the handheld over to access its rear panel.
- 2 Slide the battery release switch to the Unlock position **(a)**, then pull out the battery pack from its bay **(b)**.

1 Getting started

Preparing to use your Acer n20



IMPORTANT: Do not remove the battery pack for more than 30 minutes, unless you intend to use the expansion sleeve; otherwise you risk losing all data on the internal memory of your handheld.

Connecting the cradle

The cradle that comes with your handheld enables you to charge your handheld as well as synchronise the information on your handheld with those in your computer using ActiveSync technology.

To connect the cradle

- 1 Connect the AC adapter cord to the power socket at the back of the cradle.
- 2 Plug the AC adapter into any AC current outlet.

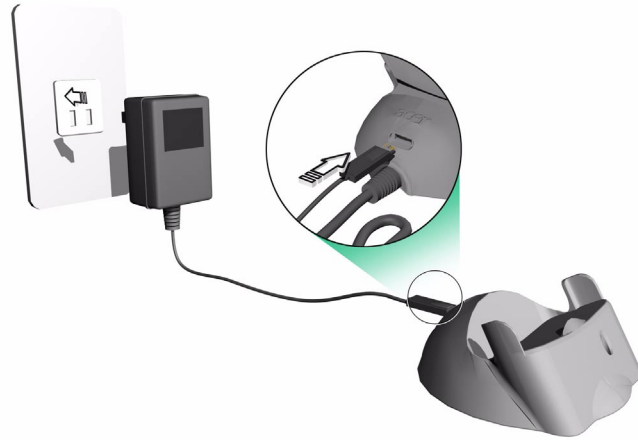

Charging your Acer n20

For initial use, you need to charge your handheld for three hours. After that, you can charge it for a few minutes each day to recharge the battery to full capacity. Normally, you can use your handheld for eight straight hours of operation before you need to recharge the battery.

To charge your Acer n20

You use the cradle to charge your handheld.

- 1 Connect the AC adapter connector to the power socket at the back of the cradle, then plug the other end of the AC adapter into any AC current outlet.
- 2 Insert your handheld into the cradle. The bottom edge of your handheld should align smoothly with the cradle when it is inserted properly.



1 Getting started

Preparing to use your Acer n20

LED status during charging:

- Charging: Flashing green
- Charging complete: Steady green

If the battery level becomes low in the course of normal use, a status icon appears on the handheld screen indicating low or very low battery status (refer to "Status icons" on page 15). Perform an ActiveSync operation to back up your data, then recharge the battery.

If your handheld shuts down (i.e., battery is completely drained out) you have about 30 minutes to recharge the battery before you lose all data on your handheld's internal memory.

The battery pack is removable. Refer to the succeeding section for instructions on how to remove it from the battery bay.

NOTE: You have the option to purchase a spare battery pack for your handheld.

Setting up your Acer n20

After you have initially charged your handheld for three hours, you can now set it up for use. Refer to the instructions below.

To set up your Acer n20

- 1 Turn on your handheld by pressing the power button on the front panel.



- 2 Follow the onscreen instructions to set up your handheld.

Performing the first synchronisation process

After completing the setup procedures you can now perform the first ActiveSync operation with the help of the 'New Partnership' setup wizard.



This wizard will help you:

- Set up a partnership so you can synchronise information between your handheld and your computer
- Customise your synchronisation settings

To perform the first synchronisation process

- 1 Connect the cradle.
For instructions, refer to page 10.
- 2 Insert your handheld in the cradle.
The bottom edge of your handheld should align smoothly with the cradle when it is inserted properly.
- 3 Plug the cradle's USB connector into a USB port on your computer.
The 'New Partnership' setup wizard will automatically start on your computer screen.

1 Getting started

Command interface



NOTE: If the wizard does not automatically appear, launch ActiveSync on your computer by clicking on its icon from *Start > Programs*.

4 Follow the onscreen instructions.

The first synchronisation process will automatically begin when you finish using the wizard.

After your first synchronisation, take a look at Calendar, Contacts, and Tasks on your handheld. You'll notice that information you've stored in Microsoft Outlook on your computer has been copied to your handheld, and you didn't have to type a word. Disconnect your handheld from your computer and you're ready to go!

Once you have set up ActiveSync and completed the first synchronisation process, you can initiate synchronisation from your handheld. To do so, on your handheld, tap , then tap ActiveSync.

NOTE: If you have a wireless LAN card, you can synchronise remotely from your handheld. For Acer n20w models, you can use the built-in IEEE 802.11b WLAN adapter.

Command interface

Hardware buttons and the stylus

Your handheld has hardware buttons that control actions and scroll functions, and a stylus for selecting items and entering information.

On your handheld, the stylus replaces the mouse.

- Tap. Touch the screen once with the stylus to open items and select options.
- Drag. Hold the stylus on the screen and drag across the screen to select text and images. Drag in a list to select multiple items.
- Tap and hold. Tap and hold the stylus on an item to see a list of actions available for that item. On the pop-up menu that appears, tap the action you want to perform.

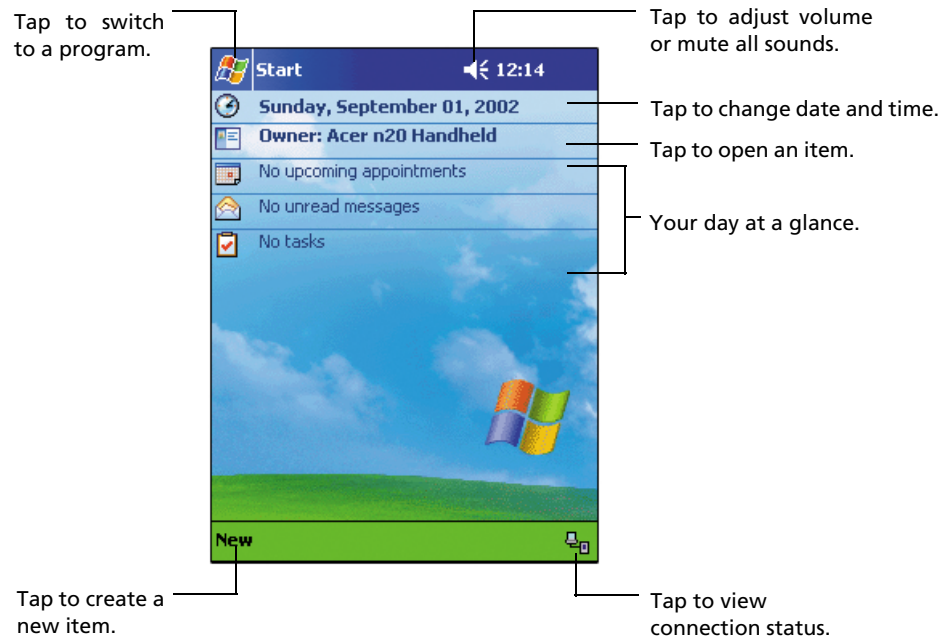

Today screen

When you turn on your handheld for the first time each day (or after 4 hours of inactivity), you'll see the Today screen. You can also display it by tapping  and then Today. On the Today screen, you can see, at a glance, a list of important reminders for the day.











Status icons

Following are some of the status icons you may see.

Status icon	Description
	Turns all sounds on and off
	Backup battery is low
	Main battery is charging

1 Getting started

Command interface

Status icon	Description
	Main battery is low
	Main battery is very low
	Main battery is full
	Connection is active
	Synchronisation is beginning or ending
	Synchronisation is occurring
	Notification ¹ that one or more instant messages were received
	Notification that one or more email messages were received

¹ If more notification icons need to be displayed than there is room to display them, the Notification icon  appears. Tap the icon to view all notification icons.

Navigation bar and command bar

The navigation bar is located at the top of the screen. It displays the active program and current time, and allows you to switch to other programs and close screens.

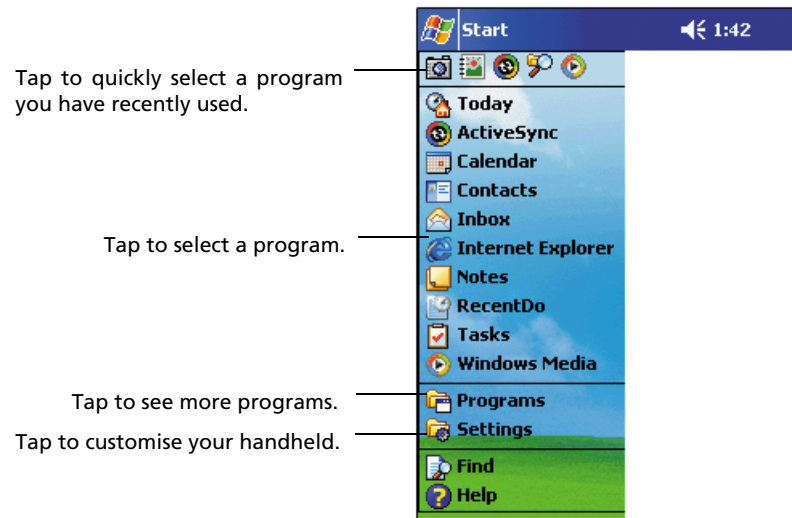

Use the command bar at the bottom of the screen to perform tasks in programs. The command bar includes menu names, buttons, and the Input Panel button.

- To create a new item in the current program, tap New.
- To see the name of a button, tap and hold the stylus on the button. Drag the stylus off the button so that the command is not carried out.

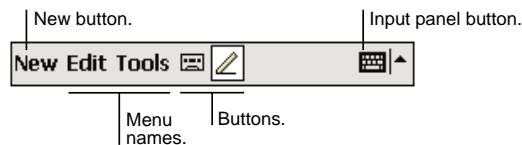

Pop-up menus

With pop-up menus, you can quickly choose an action for an item. For example, you can use the pop-up menu in the Contact list to quickly delete a contact, make a copy of a contact, or send an email message to a contact. The actions in the pop-up menu vary from program to program.

To access a pop-up menu:

- 1 Tap and hold the stylus on the item that you want to perform the action on.
- 2 When the menu appears, lift the stylus, then do any of the following:
 - Tap the action you want to perform.

1 Getting started

Command interface

- Tap anywhere outside the menu to close the menu without performing an action.

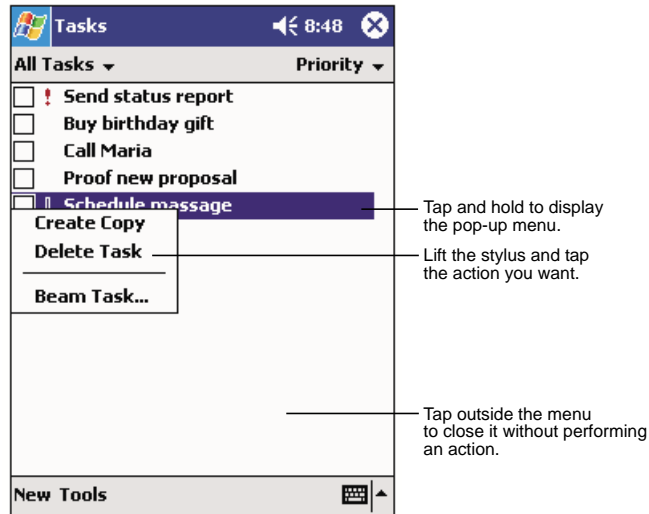

Notifications

Your handheld reminds you in a variety of ways when you have something to do. For example, if you've set up an appointment in Calendar, a task with a due date in Tasks, or an alarm in Clock, you'll be notified in any of the following ways:

- A message box appears on the screen.
- A sound, which you can specify, is played.
- The LED indicator on the front panel of your handheld flashes red.

To choose reminder types and sounds for your handheld, tap  and then Settings. In the Personal tab, tap Sounds & Notifications. The options you choose here are applied globally in your handheld.

2 Entering data in your Acer n20

You can enter data into your handheld in several ways:

- Use the input panel to enter typed text, either by using the soft keyboard or other input method.
- Write directly on the screen.
- Draw pictures on the screen.
- Speak into your handheld's microphone to record a message.
- In Inbox or MSN Messenger, use the My Text function
- Use Microsoft® ActiveSync® to synchronise or copy information from your computer to your handheld.

Refer to page 99 for detailed information on using Microsoft® ActiveSync®.

Using the input panel

Use the input panel to enter information in any program on your handheld. You can either type using the soft keyboard or write using Letter Recognizer, Block Recognizer, or Transcriber. In either case, the characters appear as typed text on the screen.

NOTE: Transcriber is available only for the English and European Acer n20 models.

To show or hide the input panel

- 1 Tap the Input Panel button.
- 2 Tap the arrow next to the Input Panel button to see your choices.

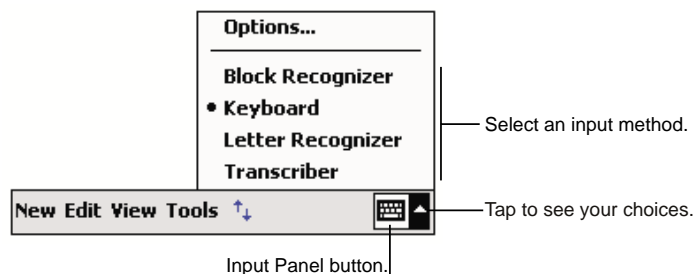

When you use the input panel, your handheld anticipates the word you are typing or writing and displays it above the input panel. When you tap the displayed word, it is

2 Entering data in your Acer n20

Using the input panel

inserted into your text at the insertion point. The more you use your handheld, the more words it learns to anticipate.

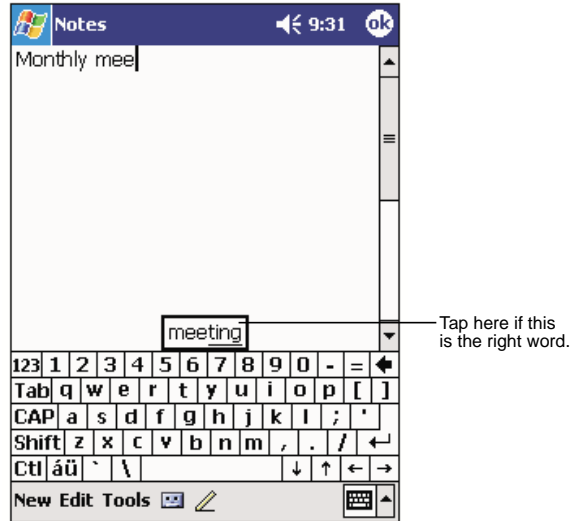

To change word suggestion options

- To set word suggestion options such as the number of words suggested at one time, tap , Settings, Personal tab, Input, and then the Word Completion tab.

To type with the soft keyboard

- 1 Tap the arrow next to the Input Panel button, then Keyboard.
- 2 On the soft keyboard that is displayed, tap the keys with your stylus.

To use Letter Recognizer

With Letter Recognizer you can write letters using the stylus just as you would on paper.

- 1 Tap the arrow next to the Input Panel button, then Letter Recognizer.
- 2 Write a letter in the box.

When you write a letter, it is converted to typed text that appears on the screen.

NOTE: For specific instructions on using Letter Recognizer, with Letter Recognizer open, tap the question mark next to the writing area.

To use Block Recognizer

With Block Recognizer you can input character strokes using the stylus that are similar to those used on other devices.

- 1 Tap the arrow next to the Input Panel button, then Block Recognizer.

- 2 Write a letter in the box.

When you write a letter, it is converted to typed text that appears on the screen.

NOTE: For specific instructions on using Block Recognizer, with Block Recognizer open, tap the question mark next to the writing area.

To use Transcriber

With Transcriber you can write anywhere on the screen using the stylus just as you would on paper.

NOTE: Transcriber is available only for the English and European Acer n20 models.

Unlike Letter Recognizer and Block Recognizer, you can write a sentence or more of information. Then, pause and let Transcriber change the written characters to typed characters.

- 1 Tap the arrow next to the Input Panel button and then Transcriber.
- 2 Write anywhere on the screen.

NOTE: For specific instructions on using Transcriber, with Transcriber open, tap the question mark in the lower right hand corner of the screen.

To select and edit typed text

If you want to edit or format typed text, you must select it first.

- 1 Drag the stylus across the text to select it.
- 2 To cut, copy, and paste typed text:
 - a Tap and hold the selected words
 - b Tap an editing command on the pop-up menu, or tap a command on the Edit menu.

Writing on the screen

In any program that accepts writing, such as the Notes program, and in the Notes tab of Calendar, Contacts, and Tasks, you can use your stylus to write directly on the screen. Write the way you do on paper. You can edit and format what you've written and convert the information to text at a later time.

2 Entering data in your Acer n20

Writing on the screen

To write on the screen

- Tap the Pen button to switch to writing mode. This action displays lines on the screen to help you write.

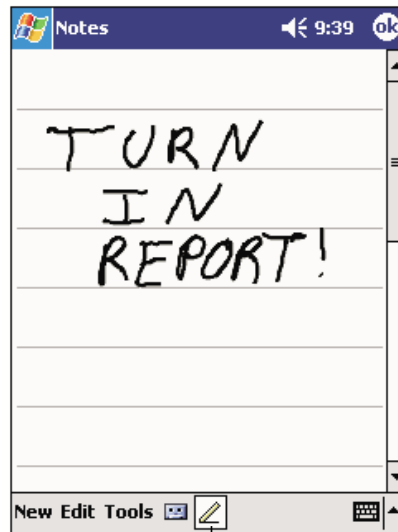

Tap the Pen button and use your stylus like a pen.

NOTE: Some programs that accept writing may not have the Pen button. See the documentation for that program to find out how to switch to writing mode.

To select and edit written text

If you want to edit or format written text, you must select it first.

- 1 Tap and hold the stylus next to the text you want to select until the insertion point appears.
- 2 Without lifting, drag the stylus across the text you want to select.

If you accidentally write on the screen, tap Tools, then Undo and try again.

-or-

Tap the Pen button to deselect it and then drag the stylus across the screen.

- 3 You cut, copy, and paste written text in the same way you work with typed text:
 - a Tap and hold the selected words
 - b Tap an editing command on the pop-up menu, or tap a command on the Edit menu.

To convert writing to text

- Tap Tools and then Recognize.

If you want to convert only certain words, select them before tapping Recognize on the Tools menu (or tap and hold the selected words and then

2 Entering data in your Acer n20 *Writing on the screen*

tap Recognize on the pop-up menu). If a word is not recognized, it is left as writing.

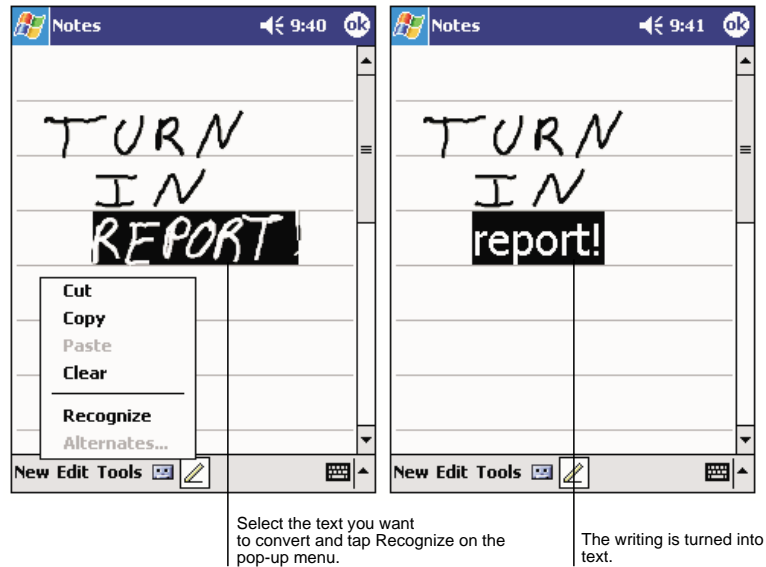

If the conversion is incorrect, you can select different words from a list of alternates or return to the original writing. To do so:

- 1 Tap and hold the incorrect word (tap one word at a time).
- 2 On the pop-up menu, tap Alternates.
A menu with a list of alternate words appears.
- 3 Do either of the following:
 - a Tap the word you want to use.
 - b Tap the writing at the top of the menu to return to the original writing.

NOTE:

Hyphenated words, foreign words that use special characters such as accents, and some punctuation cannot be converted.

If you add writing to a word to change it (such as changing a "3" to an "8") after you attempt to recognise the word, the writing you add will not be included if you attempt to recognise the writing again.

2 Entering data in your Acer n20

Drawing on the screen

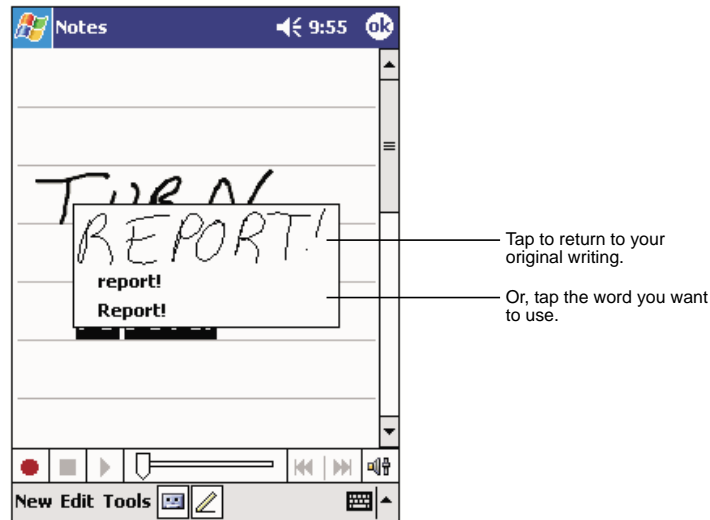

Tips for getting good recognition

- Write neatly.
- Write on the lines. Write the cross of the "t" and apostrophes below the top line so that they are not confused with the word above. Write periods and commas above the line.
- For better recognition, try increasing the zoom level to 300% using the Tools menu.
- Write the letters of a word closely and leave big gaps between words so that your handheld can easily tell where words begin and end.

Drawing on the screen

You can draw on the screen in the same way that you write on the screen. The difference between writing and drawing on the screen is how you select items and how they can be edited. For example, selected drawings can be resized, while writing cannot.

To create a drawing

- 1 Cross three ruled lines on your first stroke.
A drawing box appears.

2 Entering data in your Acer n20 *Drawing on the screen*

- 2 Subsequent strokes in or touching the drawing box become part of the drawing. Drawings that do not cross three ruled lines will be treated as writing.

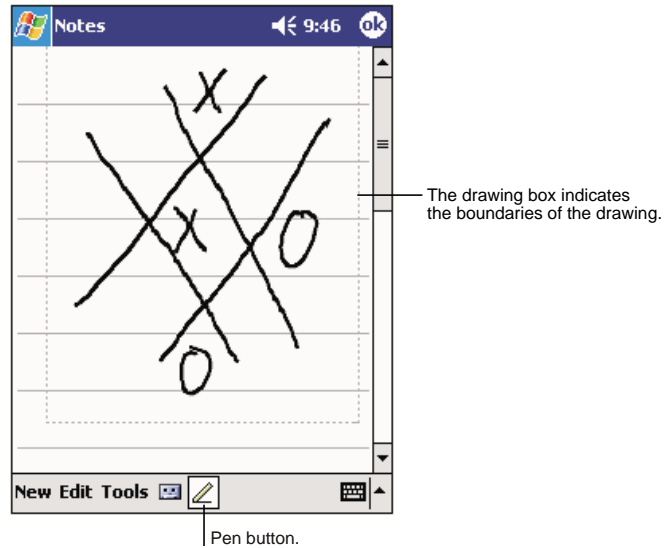

TIP: You may want to change the zoom level so that you can more easily work on or view your drawing. Tap Tools and then select a zoom level.

To select a drawing

If you want to edit or format a drawing, you must select it first.

- Tap and hold the stylus on the drawing until the selection handle appears.
- To select multiple drawings, deselect the Pen button and then drag to select the drawings you want.

To edit a drawing

- To cut, copy, and paste selected drawings:
 - a Tap and hold the selected drawing.
 - b Tap an editing command on the pop-up menu, or tap a command on the Edit menu.
- To resize a drawing:
 - a Make sure the Pen button is not selected.
 - b Drag a selection handle until desired size is attained.

Recording a message

In any program where you can write or draw on the screen, you can also quickly capture thoughts, reminders, and phone numbers by recording a message.

- In Calendar, Tasks, and Contacts, you can include a recording in the Notes tab.
- In Notes, you can either create a stand-alone recording or include a recording in a written note. If you want to include the recording in a note, open the note first.
- In Inbox, you can add a recording to an email message.

To create a recording

- 1 Hold your handheld's microphone near your mouth or other source of sound.

NOTE: Refer to "Front view" on page 3 for the location of your handheld's microphone.

- 2 Start recording by doing either of the following:
 - Press and hold (do not release) the Record hardware button on the left side of your handheld until you hear a beep.
 - Tap the Record button on the Recording toolbar.
- 3 Make your recording.
- 4 To stop recording:
 - Recording via Record hardware button: Release the Record button. Two beeps will sound.
 - Recording via the Record software button: Tap the Stop button on the Recording toolbar.

The new recording appears in the note list or as an embedded icon.

To play a recording

- Tap it in the list or tap its icon in the note.



Using My Text

When using Inbox or MSN Messenger, use My Text to quickly insert preset or frequently used messages into the text entry area.

To insert a My Text message

- 1 Tap My Text on the screen's command bar.
- 2 Tap a message.

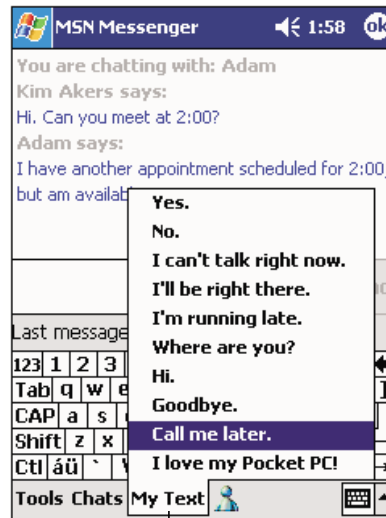

Tap to select a prewritten message.

NOTE: You can add text after inserting a My Text message before sending it.

To edit a My Text message

- 1 In the Tools menu, tap Edit and then tap My Text Messages.
- 2 Select the message you wish to edit and make the desired changes.

2 Entering data in your Acer n20

Using My Text

3 Managing applications and information

This chapter will discuss the following topics:

- Opening and switching between applications in your handheld
- Using File Explorer to manage files
- Using the Find function to look for a specific file

Opening an application

You can open applications by doing either of the following:

- Tap , Programs, and then the program name.
If you have many applications installed on your handheld, tap the scroll bar to see all the available applications.

NOTE: You can customise which programs you see on the  menu. For instructions, see "Personal" on page 122.

- Press any of the Quick buttons on the front panel of your handheld.
The icons on the buttons identify the programs.

NOTE: Based on your working style and common tasks, you can reassign the Quick buttons to other applications on your handheld. Refer to "Personal" on page 122 for instructions.

Switching between applications

Choose from the following options to switch between applications:











- Select another program from the  menu.
- Press any of the Quick buttons on the front panel of your handheld.

NOTE: Some programs have abbreviated labels for check boxes and drop-down menus. To see the full spelling of an abbreviated label, tap and hold the stylus on the label. Drag the stylus off the label so that the command is not carried out.

The following table contains a partial list of programs that are available on your handheld. Refer to the Acer n20 Handheld Companion CD for additional programs that you can install into your handheld.

3 Managing applications and information

Switching between applications

Icon	Program	Usage
	ActiveSync	Synchronise information between your handheld and your computer.
	Calendar	Keep track of your appointments and create meeting requests.
	Contacts	Keep track of your friends and colleagues.
	Inbox	Send and receive email messages.
	Pocket Internet Explorer	Browse Web and WAP sites, and download new programs and files from the Internet.
	Notes	Create handwritten or typed notes, drawings, and recordings.
	Tasks	Keep track of your tasks.
	Pocket Excel	Create new workbooks or view and edit Excel workbooks created on your computer.
	MSN Messenger	Send and receive instant messages with your MSN Messenger contacts.
	Pocket Word	Create new documents or view and edit Word documents created on your computer.

Finding and organising information

Use the Find function and the File Explorer window to search for specific files and manage your files easily.

To use Find

The Find function helps you quickly locate specific files.

- 1 On the  menu, tap Find.
- 2 Enter the text you want to find, then select a data type.

TIP: To quickly find information that is taking up storage space on your handheld, select Larger than 64 KB in Type.

- 3 Tap Go to start the search.

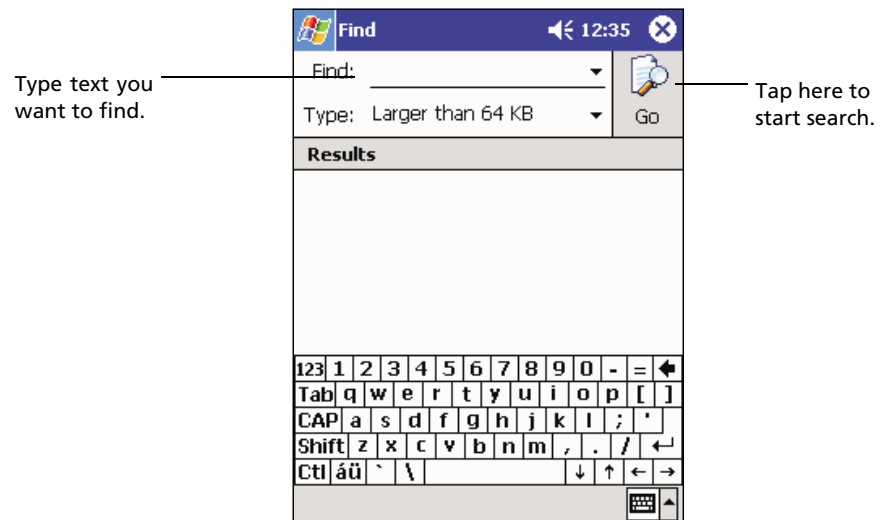

To use File Explorer

Use File Explorer to locate files on your handheld and to organise these files into folders.

- On the  menu, tap Programs, and then File Explorer.

3 Managing applications and information

Finding and organising information

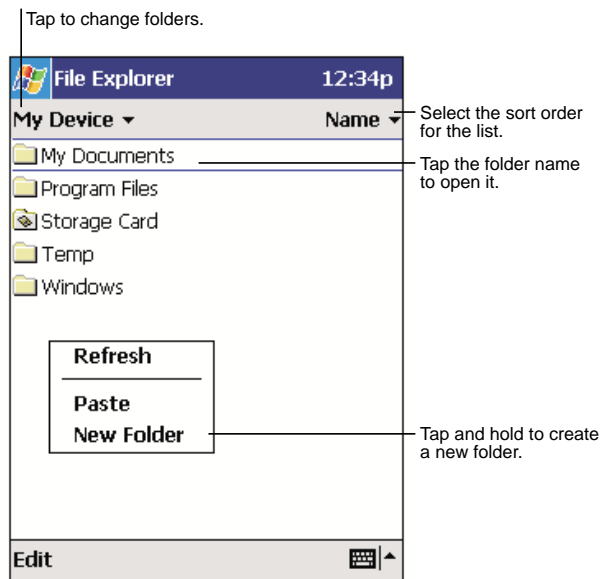

4 Managing Microsoft® Pocket Outlook applications

This chapter will discuss the basic applications included in the Microsoft® Pocket Outlook program installed in your handheld. This discussion will include:

- Calendar - schedule meetings and remind yourself of set appointments
- Contacts - keep at hand a directory of contact information
- Tasks - make a to-do list
- Notes - create textual or recorded notes of your thoughts and ideas
- Inbox - write, edit, and view your emails on the road

You can use these programs individually or in tandem with each other. For example, email addresses stored in Contacts can be used to address email messages in Inbox.

Calendar

Calendar enables you to conveniently manage your schedules and appointments or any other activities associated with a time and date. You can schedule appointments, including meetings and other events. Checking your appointments is easy using one of several views—Agenda, Day, Week, Month, and Year.

NOTE: Switch view options by using the View menu.

To open Calendar

- Press the Calendar Quick button on the front panel of your handheld. Calendar will open to today's schedule.

4 Managing Microsoft® Pocket Outlook applications

Calendar

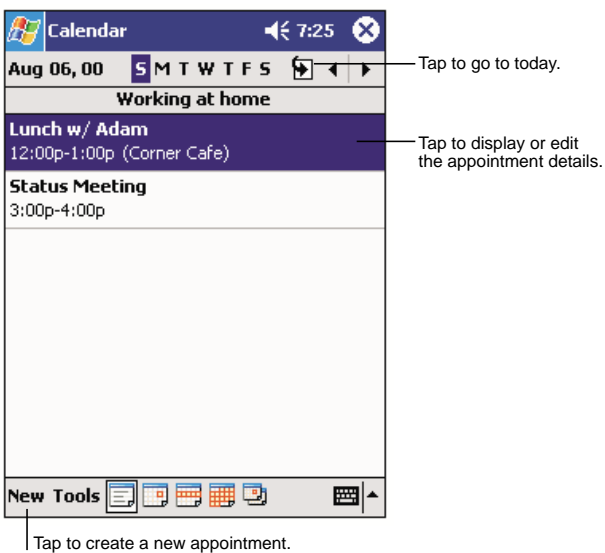

NOTE: You can customise the Calendar display, such as changing the first day of the week, by tapping Options on the Tools menu.

Scheduling an appointment

You can use Calendar to create an appointment schedule.

To create an appointment

- 1 If you are in Day or Week view, tap the desired date and time for the appointment.
- 2 Tap New.

4 Managing Microsoft® Pocket Outlook applications *Calendar*

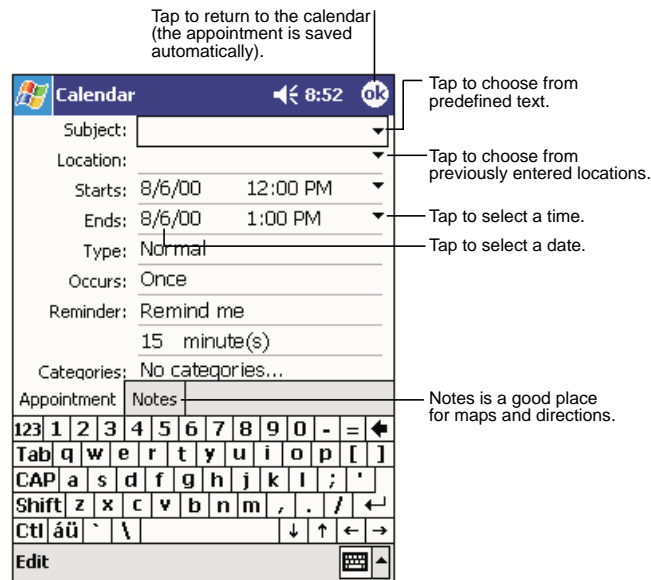

- 3 Using the input panel, enter a description and a location.
Tap first to select the field.
- 4 If needed, tap the date and time to change them.
- 5 Enter other desired information.
You will need to hide the input panel to see all available fields.
- 6 To add notes, tap the Notes tab.
You can enter text, draw, or create a recording. For more information on creating notes, see "Notes" later in this chapter.
- 7 After completing the details, tap OK.

TIP: If you select Remind me in an appointment, your handheld will remind you according to the options set in , Settings, Personal tab, Sounds & Notifications.

To use the Calendar summary screen

When you tap an appointment in Calendar, a summary screen is displayed. To change the appointment, tap Edit.

4 Managing Microsoft® Pocket Outlook applications

Contacts

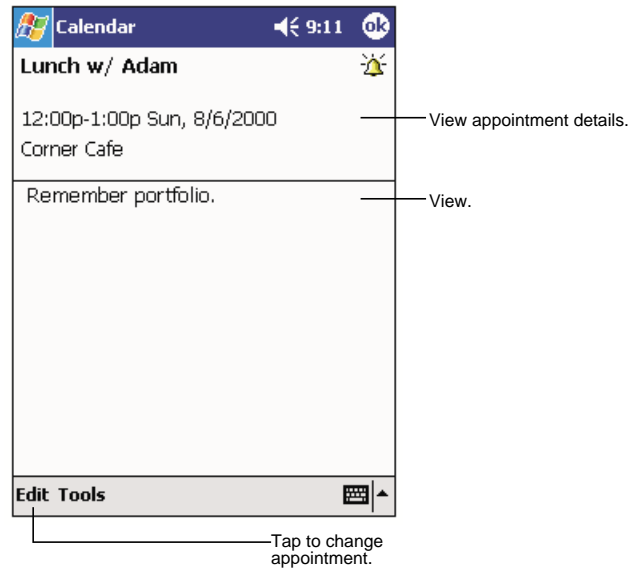

Creating a meeting request

You can use Calendar to set up meetings with users of Outlook or Pocket Outlook. The meeting request will be created automatically and sent when you synchronise Inbox or when you connect to your email server. Indicate how you want meeting requests sent by tapping Tools and then Options. If you send and receive email messages through ActiveSync, select ActiveSync.

To schedule a meeting

- 1 Create an appointment.
- 2 In the appointment details, hide the input panel, and then tap Attendees.
- 3 From the list of email addresses you've entered in Contacts, select the meeting attendees.

The meeting notice is created automatically and placed in the Outbox folder.

For more information on sending and receiving meeting requests, see the Help menu of Calendar and Inbox in your handheld.

Contacts

Contacts maintains a list of your friends' and colleagues' contact information. Using your handheld's infrared (IR) port, you can quickly share this list with other device users.

To open Contacts

- Press the Contacts Quick button on the front panel of your handheld. Contacts will open to the Contacts list.

4 Managing Microsoft® Pocket Outlook applications Contacts



NOTE: To change the way information is displayed in the list, tap Tools and then Options.

Creating a contact

- 1 Tap New.

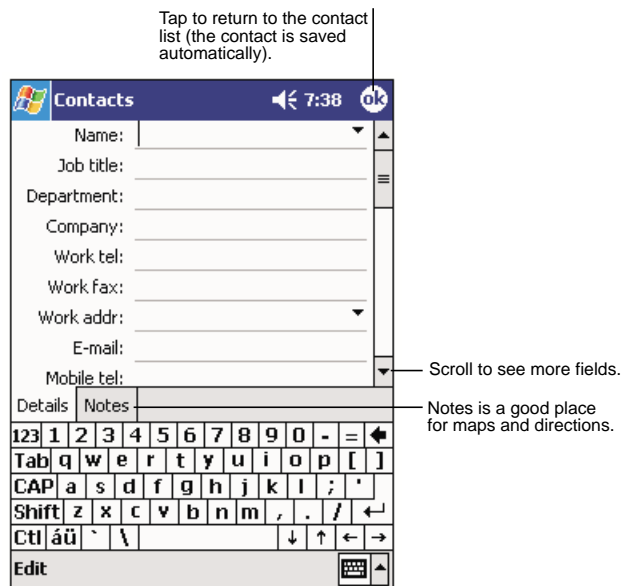

- 2 Using the input panel, enter a name and other contact information.
You will need to scroll down to see all available fields.

4 Managing Microsoft® Pocket Outlook applications

Contacts

- 3 To assign the contact to a category, scroll to and tap Categories and select a category from the list.

In the contact list, you can display contacts by category.

- 4 To add notes, tap the Notes tab.
You can enter text, draw, or create a recording. For more information on creating notes, see "Notes," later in this chapter.
- 5 After completing the details, tap OK.

Finding a contact

There are four ways to find a contact:

- In the Contact list, enter a contact name in the box under the navigation bar.
To show all contacts again, clear text from the box or tap the button to the right of the box.
- In the Contact list, tap the category list (labeled All Contacts by default) and select the type of contact that you want displayed.
To show all contacts again, select All Contacts.
To view a contact not assigned to a category, select None.
- To view the names of companies your contacts work for, in the contact list, tap *View > By Company*.
The number of contacts that work for that company will be displayed to the right of the company name.
- Tap , Find, enter the contact name, select Contacts for the type, and then tap Go.

To use the Contacts summary screen

When you tap a contact in the Contact list, a summary screen is displayed. To change the contact information, tap Edit.

4 Managing Microsoft® Pocket Outlook applications

Tasks

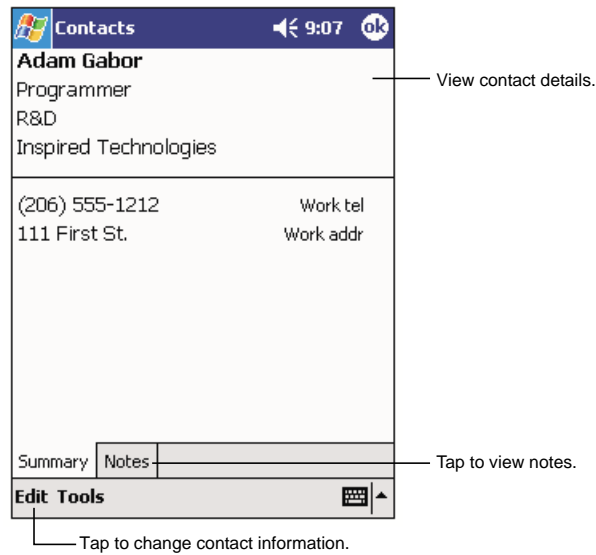

Tasks

Use Tasks to keep track of what you have to do and prioritise them based on their importance and urgency.

To open Tasks

- Tap  then, Tasks.
Tasks will open to the Tasks list.

4 Managing Microsoft® Pocket Outlook applications

Tasks

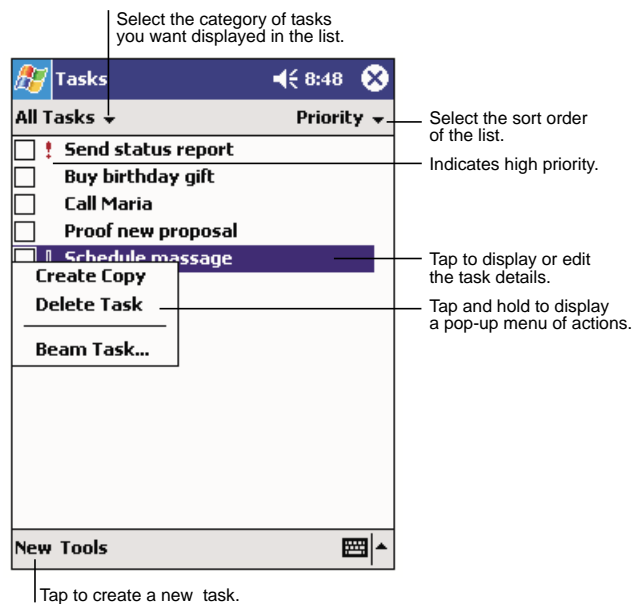

NOTE: To change the way information is displayed in the list, tap Tools and then Options.

Creating a task

- 1 Tap New.
- 2 Using the input panel, enter a description.
- 3 You can enter a start date and due date or enter other information by first tapping the field.

If the input panel is open, you will need to hide it to see all available fields.

- 4 To assign the task to a category, tap Categories and select a category from the list. In the task list, you can display tasks by category.
- 5 To add notes, tap the Notes tab.

You can enter text, draw, or create a recording. For more information on creating notes, see "Notes" later in this chapter.

4 Managing Microsoft® Pocket Outlook applications

Tasks

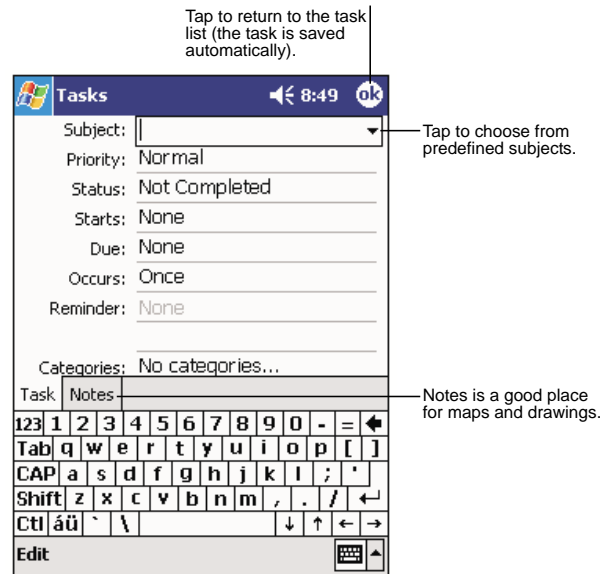

- 6 After completing the details, tap OK.

TIP: To quickly create a task with only a subject, tap Entry Bar on the Tools menu. Then, tap Tap Here to add a new task and enter your task information.

To use the Tasks summary screen

When you tap a task in the task list, a summary screen is displayed. To change the task, tap Edit.

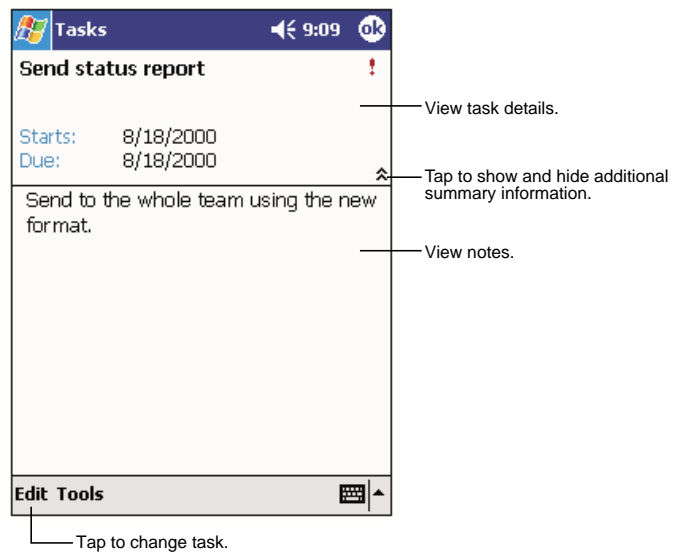

4 Managing Microsoft® Pocket Outlook applications

Notes

Notes

Quickly capture thoughts, reminders, ideas, drawings, and phone numbers with Notes. You can create a written note or a recording. You can also include a recording in a note. If a note is open when you create the recording, it will be included in the note as an icon. If the note list is displayed, it will be created as a stand-alone recording.

To open Notes

- Tap  then, Notes.
Notes will open to the Notes list.

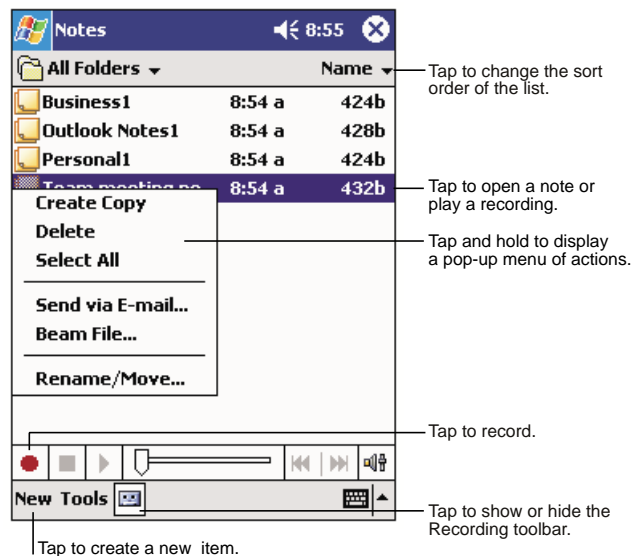

Creating a note

- 1 Tap New.
- 2 Create the note by writing, drawing, typing, or recording.

NOTE: For more information about using the input panel, writing and drawing on the screen, and creating recordings, see "2 Entering data in your Acer n20" on page 19.

4 Managing Microsoft® Pocket Outlook applications

Inbox

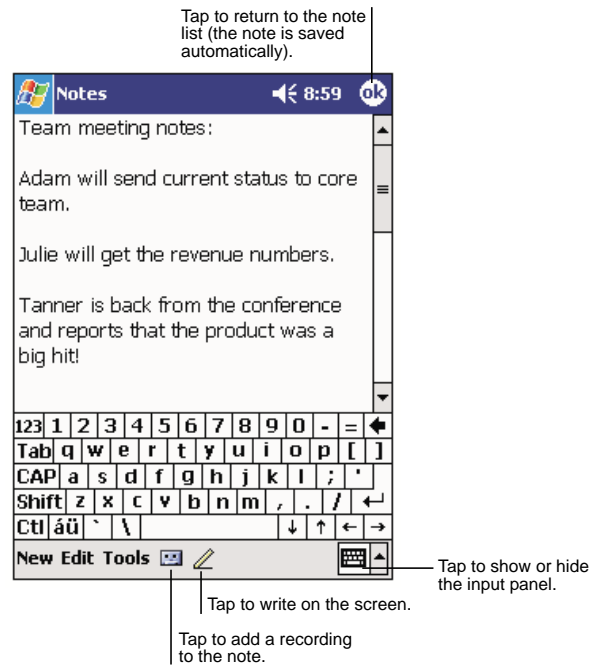

Inbox

Use Inbox to send and receive email messages by doing either of the following:

- Synchronise email messages with Microsoft Exchange or Microsoft Outlook on your computer.
- Send and receive email messages by connecting directly to an email server through an Internet service provider (ISP) or a network.

To open Inbox

- Press the Inbox Quick button on the front panel of your handheld. Inbox will open to the Inbox' folder navigator.

4 Managing Microsoft® Pocket Outlook applications

Inbox

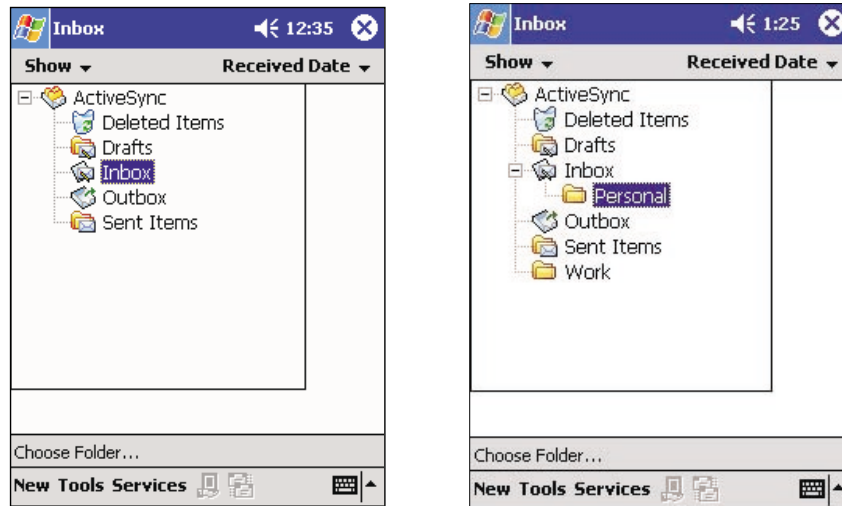

Synchronising email messages

Email messages can be synchronised as part of the general synchronisation process. You will need to enable Inbox synchronisation in ActiveSync.

For information on enabling Inbox synchronisation, see ActiveSync Help on your computer.

During synchronisation:

- Messages are copied from the mail folders of Exchange or Outlook on your computer to the ActiveSync folder in Inbox on your handheld. By default, you will receive messages from the past three days only, the first 100 lines of each message, and file attachments of less than 100 KB in size.
- Email messages in the Outbox folder on your handheld are transferred to Exchange or Outlook, and then sent from those programs.
- Email messages in subfolders must be selected in ActiveSync on your computer in order to be transferred.

TIP: You can also synchronise email messages with your computer from a remote location. For more information, see the ActiveSync Help menu in your computer.

Connecting directly to an email server

In addition to synchronising email messages with your computer, you can send and receive email messages by connecting to an email server using a modem or a network card connected to your handheld. You'll need to set up a remote connection to a network or an ISP, and a connection to your email server. For more information, refer to "9 Getting connected" on page 101.

When you connect to the email server, new messages are downloaded to your handheld's Inbox folder, messages in the handheld's Outbox folder are sent, and messages that have been deleted on the email server are removed from the handheld's Inbox folder.

4 Managing Microsoft® Pocket Outlook applications

Inbox

Messages that you receive directly from an email server are linked to your email server rather than your computer. When you delete a message on your handheld, it is also deleted from the email server the next time you connect based on the settings you selected in ActiveSync.

You can work online or offline. When working online, you read and respond to messages while connected to the email server. Messages are sent as soon as you tap Send, which saves space on your handheld.

When working offline, once you've downloaded new message headers or partial messages, you can disconnect from the email server and then decide which messages to download completely. The next time you connect, Inbox downloads the complete messages you've marked for retrieval and sends the messages you've composed.

Using the Message list

The messages you receive are displayed in the Message list. By default, the most recently received messages are displayed first in the list.

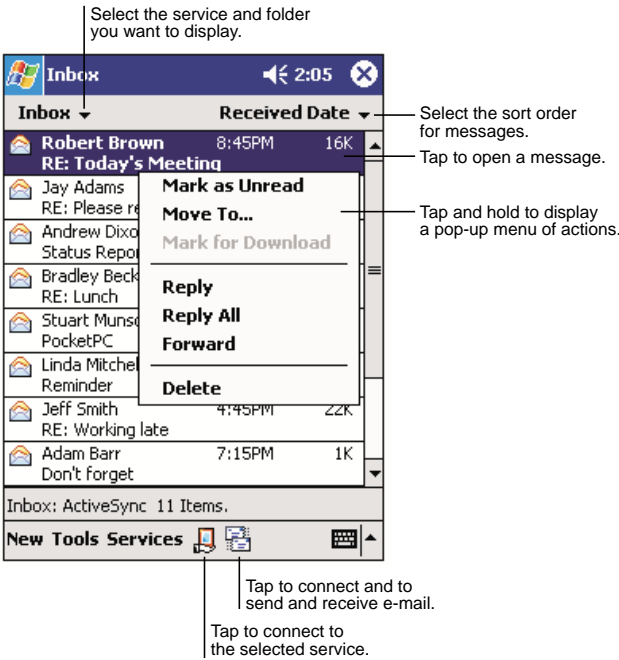

When you receive a message, tap it to open it. Unread messages are displayed in bold.

4 Managing Microsoft® Pocket Outlook applications

Inbox

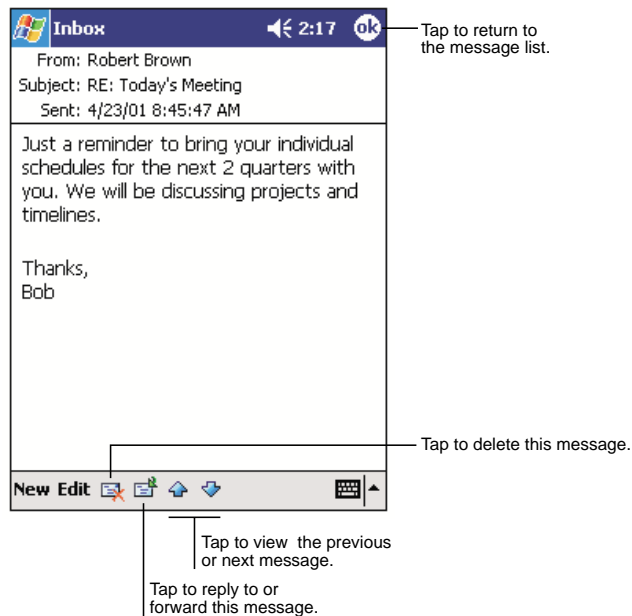

When you connect to your email server, by default, you'll receive messages from the last five days only, the first 100 lines of each new message, and file attachments of less than 100 KB in size. The original messages remain on the email server or your computer.

You can mark the messages that you want to retrieve in full during your next synchronisation or email server connection. Follow the steps below.

- 1 In the Message list, tap and hold the message you want to retrieve.
- 2 On the pop-up menu, tap Mark for Download. The icons in the Inbox message list give you visual indications of message status.

Specify your downloading preferences when you set up the service or select your synchronisation options. You can change them at any time:

- Change options for Inbox synchronisation using ActiveSync options. For more information, see ActiveSync Help.
- To change options for direct email server connections. In Inbox on your handheld:
 - a Tap Tools and then tap Options.
 - b On the Service tab, tap the service you want to change.
 - c Tap and hold the service and select Delete to remove a service.

Composing a message

- 1 Tap New.
- 2 In the To field, enter an email or SMS address of one or more recipients, separating them with a semicolon, or select a name from the contact list by tapping the Address Book button.

All email addresses entered in the email fields in Contacts appear in the Address Book.

4 Managing Microsoft® Pocket Outlook applications

Inbox

3 Compose your message.

To enter preset or frequently used messages, tap My Text and select a message.

If you are sending an SMS message and want to know if it was received, tap Edit, Options, and select Request SMS text message delivery notification.

4 Tap Send when you've finished the message.

If you are working offline, the message is moved to the Outbox folder and will be sent the next time you connect.

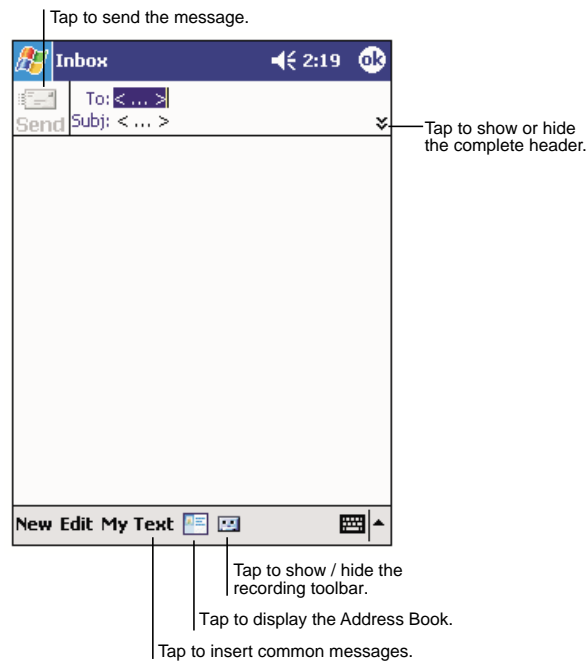

Managing email messages and folders

By default, messages are displayed in one of five folders for each service you have created: Inbox, Deleted Items, Drafts, Outbox, and Sent Items.

- The behavior of the Deleted and Sent Items folders depends on the options you have chosen. To set these options, in the Message list:
 - a Tap Tools and then Options.
 - b On the Message tab, select your options.
- If you want to organise messages into additional folders, tap Tools, and then Manage Folders to create new folders.
- To move a message to another folder, in the Message list, tap and hold the message and then tap Move to on the pop-up menu.

Folder behavior with a direct connection to an email server

The behavior of the folders you create depends on whether you are using ActiveSync, SMS, POP3, or IMAP4.

- If you use ActiveSync, email messages in the Inbox folder in Outlook will automatically be synchronised with your handheld. You can select to synchronise additional folders by designating them for ActiveSync. The folders you create and the messages you move will then be mirrored on the server. For example, if you move two messages from the Inbox folder to a folder named Family, and you have designated Family for synchronisation, the server creates a copy of the Family folder and copies the messages into that folder. You can then read the messages while away from your computer.
- If you use SMS, messages are stored in the Inbox folder.
- If you use POP3 and you move email messages to a folder you created, the link is broken between the messages on your handheld and their copies on the email server. The next time you connect, the email server will see that the messages are missing from the handheld's Inbox and delete them from the server. This prevents you from having duplicate copies of a message, but it also means that you will no longer have access to messages that you move to folders created from anywhere except your handheld.
- If you use IMAP4, the folders you create and the email messages you move are mirrored on the server. Therefore, messages are available to you anytime you connect to your email server, whether it is from your handheld or from your computer. This synchronisation of folders occurs whenever you connect to your mail server, create new folders, or rename/delete folders when connected.

5 Managing Microsoft® Pocket PC 2002 companion programs

Perform your usual computing tasks on-the-road using the Microsoft® Pocket PC 2002 companion programs which include:

- Pocket Word
- Pocket Excel
- MSN® Messenger
- Microsoft® Windows Media™ Player for Pocket PC
- Microsoft® Reader for Pocket PC



NOTE: Microsoft® Reader is available only for the English and European Acer n20 models.

To open a companion program on your handheld, tap Programs on the  menu, and then tap the program name.

Pocket Word

Pocket Word works with Microsoft Word on your computer to give you easy access to copies of your documents. You can:

- Create new documents on your handheld, such as letters, meeting minutes, and trip reports, or you can copy documents from your computer to your handheld.
- Synchronise documents between your computer and your handheld so that you have the most up-to-date content in both locations.

For more information on using Pocket Word, tap  > Programs > Pocket Word then, tap Help from the  menu.

Creating a new file

- Tap , Programs, Pocket Word, and then New.
A blank document appears. Or, if you've selected a template for new documents in the Options dialog box, that template appears with appropriate text and formatting already provided.

You can open only one document at a time; when you open a second document, you'll be asked to save the first. You can save a document you create or edit in a variety of formats, including:

- Word (.doc)
- Pocket Word (.psw)
- Rich Text Format (.rtf)
- Plain Text (.txt)

5 Managing Microsoft® Pocket PC 2002 companion programs

Pocket Word

To use the Pocket Word file list

Pocket Word contains a list of the files stored on your handheld.

- Tap a file in the list to open it.
- To delete, make copies of, and send files, tap and hold a file in the list. Then, select the appropriate action on the pop-up menu.

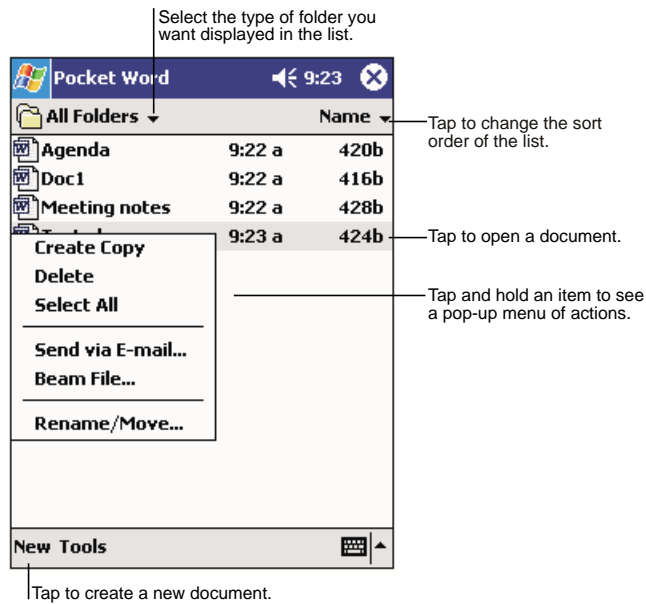

Entering information

You can enter information in Pocket Word in one of four modes—typing, writing, drawing, and recording, which are displayed on the View menu. Each mode has its own toolbar, which you can show and hide by tapping the Show/Hide Toolbar button on the command bar.

If you're opening a Word document created on a computer, select Wrap to Window on the View menu so that you can see the entire document.

TIP: You can change the zoom magnification by tapping View and then Zoom. Then select the percentage you want. Select a higher percentage to enter text and a lower one to see more of your document.

Typing mode

- Using the input panel, enter typed text into the document.
For more information on entering typed text, see "Using the input panel" on page 19.
- To format existing text and to edit text, first select the text. You can select text as you do in a Word document, using your stylus instead of the mouse to drag through the text you want to select.

- You can search a document to find text by tapping Edit and then Find/Replace.

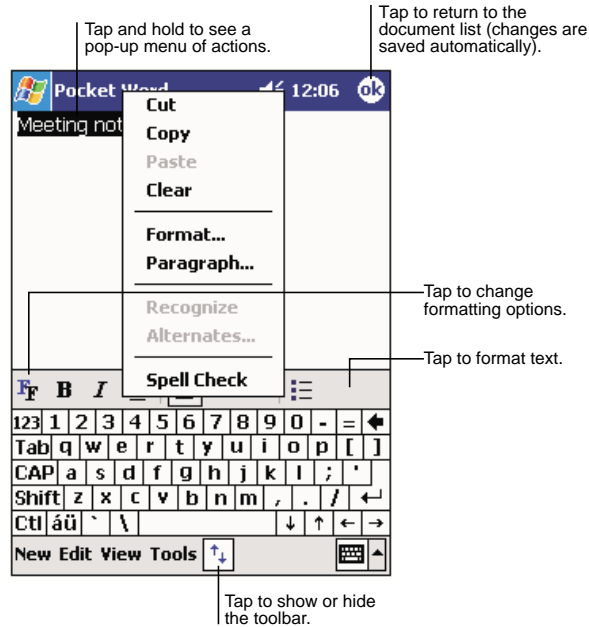

Writing mode

In writing mode, use your stylus to write directly on the screen. Ruled lines are displayed as a guide, and the zoom magnification is greater than in typing mode to allow you to write more easily.

For more information on writing and selecting writing, see "Writing on the screen" on page 21.

5 Managing Microsoft® Pocket PC 2002 companion programs

Pocket Word

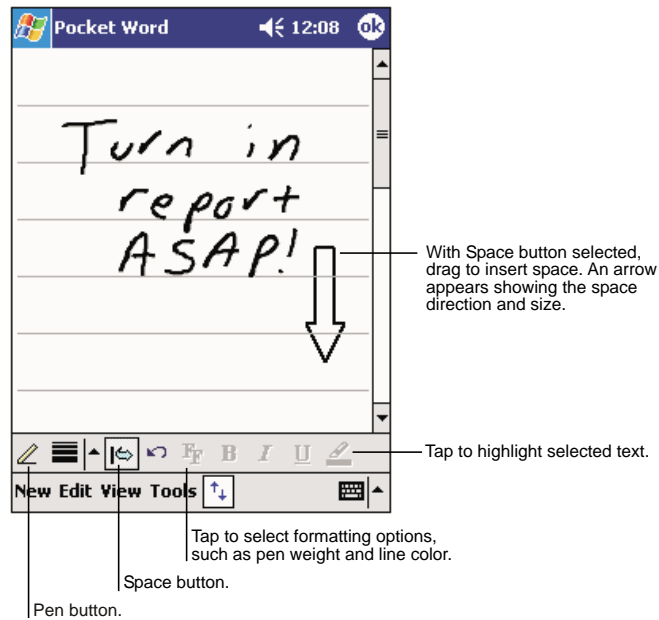

If you cross three ruled lines in a single stylus stroke, the writing becomes a drawing, and can be edited and manipulated as described in the following section.

NOTE: Written words are converted to graphics (metafiles) when a Pocket Word document is converted to a Word document on your computer.

Drawing mode

In drawing mode, use your stylus to draw on the screen. Gridlines appear as a guide. When you lift your stylus off the screen after the first stroke, you'll see a drawing box indicating the boundaries of the drawing. Every subsequent stroke within or touching the drawing box becomes part of the drawing.

For more information on drawing and selecting drawings, see "Drawing on the screen" on page 24.

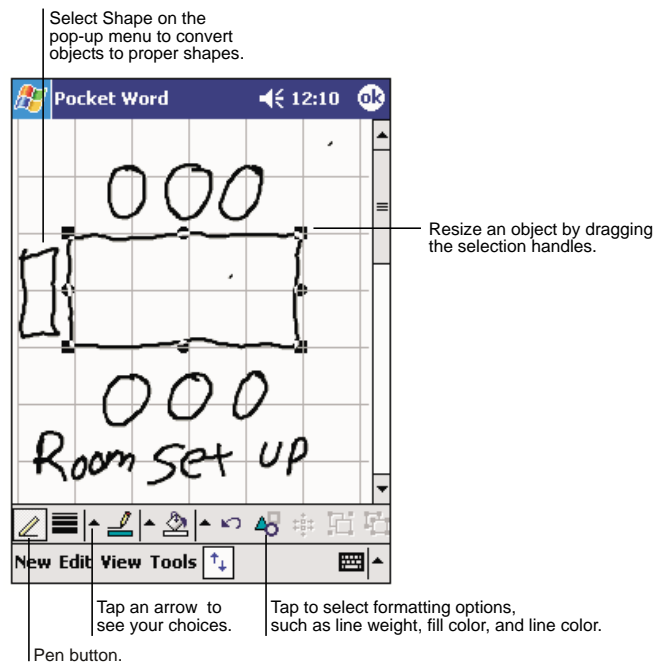

Recording mode



In recording mode, you can embed a recording into your document. Recordings are saved as .wav files.

For more information on recording, see "Recording a message" on page 26.

Pocket Excel

Pocket Excel works with Microsoft Excel on your computer to give you easy access to copies of your workbooks. You can:

- Create new workbooks on your handheld, such as expense reports and mileage logs, or you can copy workbooks from your computer to your handheld.
- Synchronise workbooks between your computer and your handheld so that you have the most up-to-date content in both locations.

For more information on using Pocket Excel, tap  > Programs > Pocket Excel then, tap Help from the  menu.

Creating a new workbook

- Tap , Programs, Pocket Excel, and then New.
A blank workbook appears. Or, if you've selected a template for new workbooks in the Options dialog box, that template appears with appropriate text and formatting already provided.

5 Managing Microsoft® Pocket PC 2002 companion programs

Pocket Excel

You can open only one workbook at a time; when you open a second workbook, you'll be asked to save the first. You can save a workbook you create or edit in a variety of formats, including:

- Pocket Excel (.pxl)
- Excel (.xls)

To use the Pocket Excel file list

Pocket Excel contains a list of the files stored on your handheld.

- Tap a file in the list to open it.
- To delete, make copies of, and send files, tap and hold a file in the list. Then select the appropriate action from the pop-up menu.

Displaying the toolbar

Pocket Excel provides fundamental spreadsheet tools, such as formulas, functions, sorting, and filtering, in its toolbar.

- Tap View and then Toolbar.

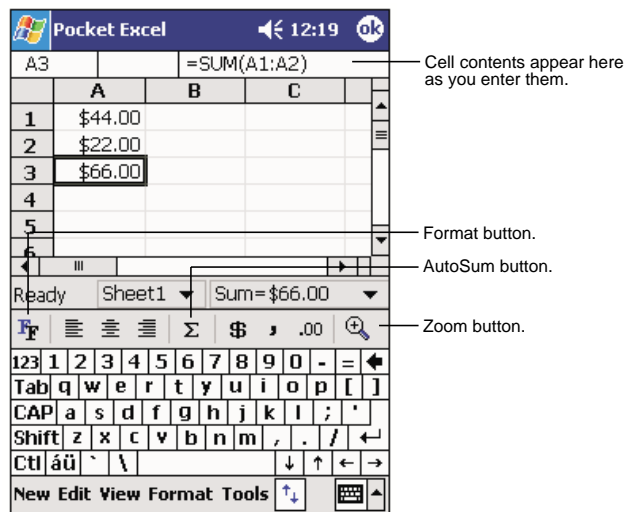

Protecting your workbooks

If your workbook contains sensitive information, you can protect it with a password.

- Open the workbook, tap Edit, and then Password.
Every time you open the workbook, you will need to enter the password, so choose one that is easy for you to remember but hard for others to guess.

Tips for working in Pocket Excel

Note the following when working in large worksheets in Pocket Excel:



- View in full-screen mode to see as much of your worksheet as possible.

- Tap View and then Full Screen.
- To exit full-screen mode, tap Restore.
- Show and hide window elements.
 - Tap View and then tap the elements you want to show or hide.
- You might want to freeze the top and left-most panes in a worksheet to keep row and column labels visible as you scroll through a sheet.
 - a Select the cell where you want to freeze panes.
 - b Tap View and then Freeze Panes.
- Split panes to view different areas of a large worksheet.
 - a Tap View and then Split.
 - b Then drag the split bar to where you want it.
To remove the split, tap View and then Remove Split.
- Show and hide rows and columns.
 - To hide a hidden row or column:
 - a Select a cell in the row or column you want to hide.
 - b Tap Format, then Row or Column, and then Hide.
 - To show a hidden row or column:
 - a Tap Tools, then Go To.
 - b Type a reference that is in the hidden row or column.
 - c Tap Format, then Row or Column, and then Unhide.

MSN® Messenger

MSN® Messenger on your handheld is an instant messaging program that lets you:

- See who is online
- Send and receive instant messages
- Have instant message conversations with groups of contacts

For more information on using MSN Messenger, tap  > *Programs* > *MSN Messenger* then, tap Help from the  menu.

Requirements to use MSN Messenger

- Microsoft Passport™ account or a Microsoft Exchange email account.
- Passport to use MSN Messenger Service. If you have a Hotmail® or MSN account, you already have a Passport.

Once you have obtained either a Microsoft Passport or a Microsoft Exchange account, you are ready to set up your account.

TIP: Sign up for a Microsoft Passport account at (<http://www.passport.com/>). Get a free Microsoft Hotmail email address at (<http://www.hotmail.com/>).

Setting up an account

Before you can connect, you must enter Passport or Exchange account information.

To set up an account and sign in:

- 1 In the Tools menu, tap Options.
- 2 In the Accounts tab, enter your Passport or Exchange account information.
- 3 To sign in, tap the sign-in screen and enter your email address and password.

NOTE: If you already use MSN Messenger on your computer, your contacts will show up on your handheld without being added again.

Working with contacts

The MSN Messenger window shows all of your messenger contacts at a glance, divided into Online and Not Online categories. From this view, while connected, you can chat, send a email, block the contact from chatting with you, or delete contacts from your list using the pop-up menu.

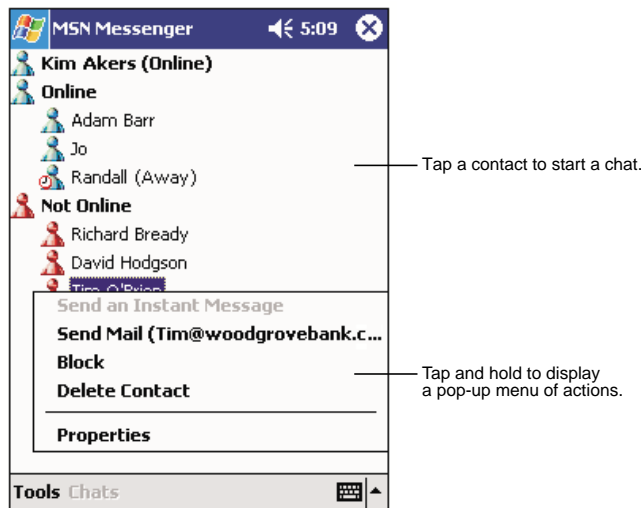

- To see others online without being seen, in the Tools menu, tap My Status and select Appear Offline.
- If you block a contact, you will appear offline but will remain on the blocked contact's list.
- To unblock a contact, tap and hold the contact, then tap Unblock on the pop-up menu.

Chatting with contacts

- 1 Tap a contact name to open a chat window.
- 2 Enter your message in the text entry area at the bottom of the screen, or tap My Text to enter a preset message.

5 Managing Microsoft® Pocket PC 2002 companion programs *Microsoft® Windows Media™ Player for Pocket PC*

3 Tap Send.



Tips when chatting with contacts

- To invite another contact to a multi-user chat, in the Tools menu, tap Invite and tap the contact you want to invite.
- To switch back to the main window without closing a chat, tap the Contacts button.
- To revert back to your chat window, tap Chats and select the person whom you were chatting with.
- To know if the contact you are chatting with is responding, look for the message under the text entry area.

Microsoft® Windows Media™ Player for Pocket PC

Use Microsoft® Windows Media™ Player for Pocket PC to play digital audio and video files (Windows Media and MP3 files) that are:

- Stored on your handheld
- Copied from Microsoft Windows Media Player on your computer to your handheld
- On a network

5 Managing Microsoft® Pocket PC 2002 companion programs *Microsoft® Reader for Pocket PC*

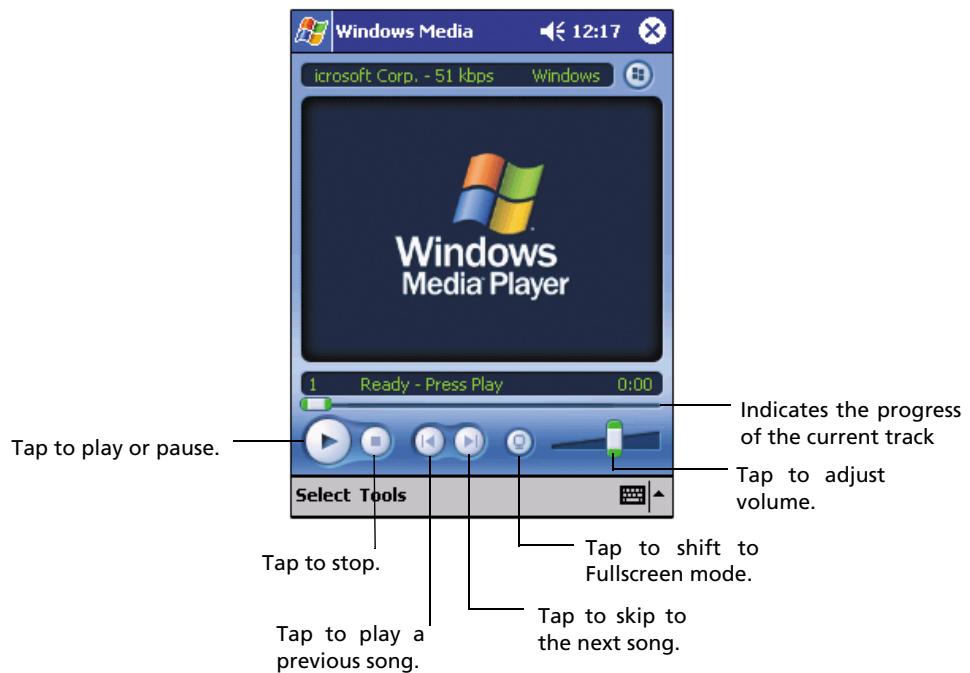

For more information about using Windows Media Player for Pocket PC, tap , and then tap Help.

Microsoft® Reader for Pocket PC

Use Microsoft® Reader for Pocket PC to read eBooks on your handheld. You can also download books from your favorite eBook Web site to your computer. Then, use ActiveSync to copy the book files to your handheld. The books appear in the Reader Library, where you can tap them in the list to open them.

NOTE: Microsoft® Reader is available only for the English and European Acer n20 models.

Using Guidebook

Guidebook contains all the information you'll need to use the Microsoft Reader.

To open Guidebook:

- Tap Help on the Reader command bar.
- or-
- On a book page, tap and hold on the book title, and then tap Help on the pop-up menu.

Getting books on your Acer n20

You can download book files from the Web. Just visit your favorite eBook retailer and follow the instructions to download the book files.

Some sample books and a dictionary are included in the MSReader folder. This folder is located in the Extras folder on the Acer n20 Handheld Companion CD.

Use ActiveSync to download the files from your computer to your handheld as described in the Read Me file in the MSReader folder.

Using Library

The Library is your Reader home page; it displays a list of all books stored on your handheld or storage card.

To open Library:

- On the Reader command bar, tap Library.
- or-
- On a book page, tap the book title, and then tap Library on the pop-up menu.

Opening a book

- Tap a book title in the Library list.

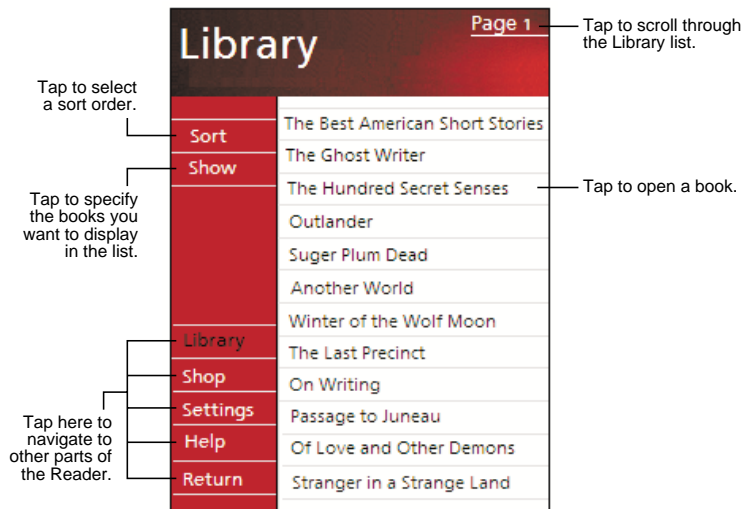

Reading a book

Each book consists of a cover page, an optional table of contents, and the pages of the book. You can:

- Annotate the book with highlighting, bookmarks, notes, and drawings.
- Search for text and look up definitions for words.

In addition to the text, each book page includes a page number and book title.

5 Managing Microsoft® Pocket PC 2002 companion programs

Microsoft® Reader for Pocket PC

Navigation options are listed in the bottom portion of the cover page. Page through the book by:

- Using the Directional pad or the Scroll wheel on your handheld
- Tapping the page number on each page

The first time you open a book, the table of contents, if there is one, will be displayed. Subsequently, whenever you open the book, you'll be automatically taken to the last page read.

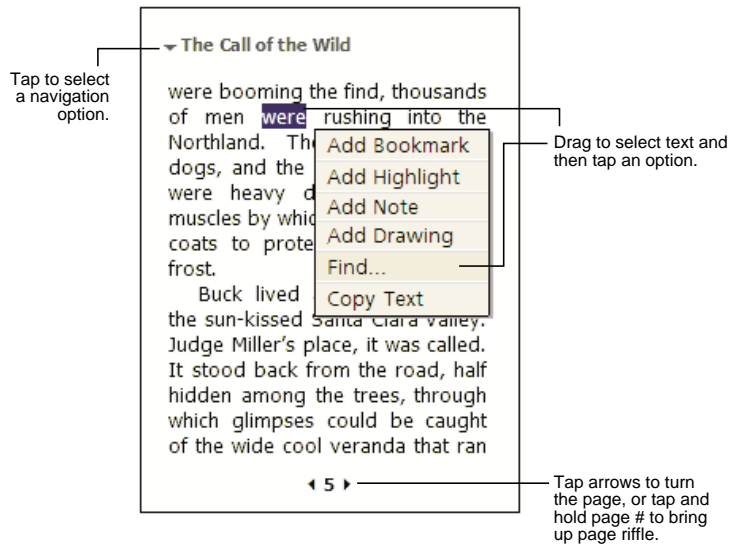

Using the Reader features

Reading a book electronically gives you several options not available with paper books. These options are available from any book page.

Select text by dragging across the text on the page. Then, tap an option on the pop-up menu, as described in the following sections.

To search for text

- 1 Tap Find on the pop-up menu.
- 2 Enter the word you want to search for.
- 3 Tap the desired Find option.

Reader highlights found matching text on the page.

- To close Find, tap outside the box.
- To return to your original page, tap the title and then tap Return on the pop-up menu.

To copy text

You can copy text from books that support this feature into any program that accepts text.

- 1 On a book page, select the text you want to copy.

- 2 Tap Copy Text on the pop-up menu.
The text can be pasted into the program of your choice.

To view book annotations

To see a list of a book's annotations, including bookmarks, highlights, text notes, and drawings:

- 1 Tap Annotations Index on the book's cover page.
- 2 Tap an entry in the list to go to the annotated page.

Bookmarks

- When you add a bookmark to a book, a colour-coded bookmark icon appears in the right margin. From anywhere in the book, tap the bookmark icon to go to the bookmarked page.

NOTE: You can add multiple bookmarks to a book.

Highlights

- When you highlight text, it appears with a coloured background.

Notes

- When you attach a note to text, you enter the text in a note pad that appears on top of the book page. A Note icon will appear in the left margin. To show or hide the note, tap the icon.

Drawings

- When you add a drawing, a Drawing icon appears in the bottom-left corner of the page, and drawing tools appear across the bottom of the page. Draw by dragging your stylus.

Removing a book

When you finish reading a book, you can delete it to conserve space on your handheld. If a copy of the book is stored on your computer, you can download it again at any time.

- 1 Tap and hold the title in the Library list.
- 2 Tap Delete on the pop-up menu.

6 Using third-party applications

Several third-party applications are included in the Acer n20 Handheld Companion CD. These applications are designed to complement the functions of your handheld.

RecentDo	Provides a quick way to launch the most recently accessed programs, documents and websites.
Backup/Restore	Backs up data files and applications in your handheld's internal memory to a storage card and restores them back when you need them.
IA Album LE	Views and edits standard image files such as JPEG, BMP, and GIF files.
Acrobat Reader for Pocket PC ¹	Views Acrobat Reader (.pdf) files
PocketTV Enterprise Edition ¹	Allows playback of standard MPEG-1 files

¹ Application available only for the English and European Acer n20 models.

RecentDo

Using RecentDo, you can conveniently scan a list of the most recently accessed programs, documents and websites.

Documents that have been edited and saved will be listed in RecentDo as well as documents opened by Microsoft Media Player or PocketTV; Documents that were only opened and viewed will not be included.

To launch RecentDo, simply tap its icon  on the navigation bar.

Items in the RecentDo window are categorised into three—Programs, Documents, and Websites. Listed items are shown in hypertext format so you can easily launch them.

6 Using third-party applications

Backup/Restore

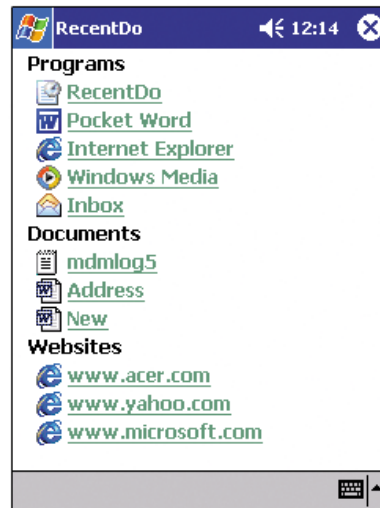

NOTE: Each category can contain a maximum of five items at a time.

Backup/Restore

Backup/Restore enables you to back up data files and applications in your handheld's internal memory to a storage card and to restore backup data to your handheld. Your handheld's expansion features allow you to use any of the following storage cards:

- *Memory Stick* - via the built-in *Memory Stick* slot
- CompactFlash - using the optional expansion sleeve
- PC Card - using the optional expansion sleeve

For more information on these expansion features, refer to "7 Using expansion features" on page 91.

During a backup or restore operation:

- All hardware buttons are disabled as well as the automatic handheld off feature
- The power button serve as a pause/resume button to control the pace of backup/restore operation

There are two tabs in the program window corresponding to the two function of Backup and Restore.

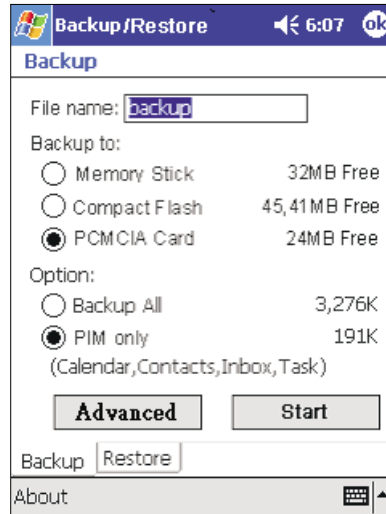

To launch Backup/Restore:

- 1 Insert a storage card into the appropriate slot.
For instructions on how to insert a *Memory Stick*, refer to page 91.
If you will be using either a CompactFlash card or a PC Card, attach first your handheld to the expansion sleeve (optional accessory, sold separately). Refer to page 94 for instructions on how to attach the expansion sleeve to your handheld.
- 2 Tap , Programs, and then Backup/Restore.
Note that when you attempt to launch Backup/Restore without any storage card available in the system, option for that unavailable storage card will be disabled.
When the selected storage card is removed during the backup or restore process, a warning message will pop up.

6 Using third-party applications Backup/Restore

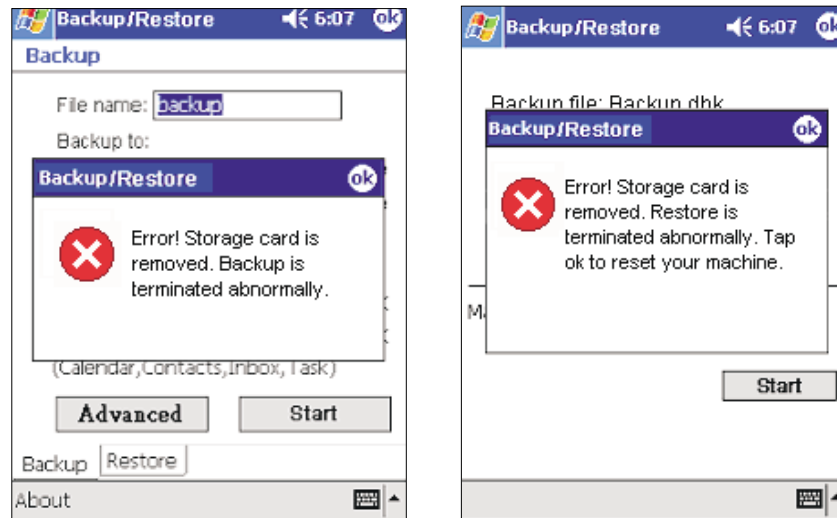

Backup function

The Backup function has two operating modes—Normal Backup and Advanced Backup. In the Advanced mode, you can set to perform an automatic data backup when the system is running on x battery power; x being the set battery capacity defined in the Advanced window.

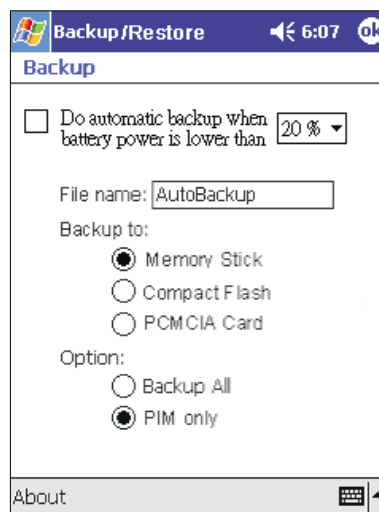

Note that no backup procedure will be performed when the Advanced backup setting is activated and the specified storage card (default: *Memory Stick*) is not attached to your handheld when x battery level is reached.

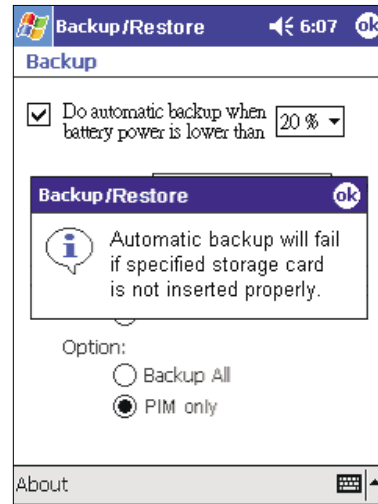

NOTE: 'AutoBackup' is the default filename of a backup file generated using the Advanced mode.

To perform data backup

- 1 Close all running programs except for Backup/Restore.
- 2 In the Backup tab, choose whether to accept the default filename (backup) or type a new one by tapping the keyboard icon on the bottom of the screen.
- 3 Select a storage card (default: *Memory Stick*) from the 'Backup to' radio buttons.
- 4 Define the backup scope (default: PIM only) from the Option' radio buttons.

If free space in the selected storage card is less than the size of the data to be copied from the handheld's internal memory, a warning message will pop up.

6 Using third-party applications

Backup/Restore

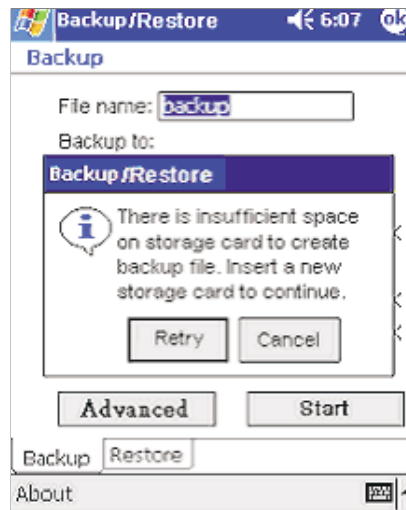

Tap **Retry** to revert to the **Backup** tab, then either delete files from the selected storage card to increase its free space or select a new storage card with a enough space to accommodate the size of the intended backup data.

Refer to page 74 for instructions on how to delete a file from a storage card.

- 5 Tap **Start** to proceed with the backup process.

If a backup file of the same filename as set exists in the selected storage card, a pop-up message appears.

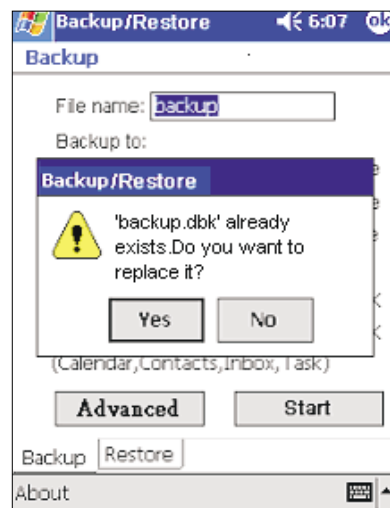

6 Using third-party applications *Backup/Restore*

Tap Yes to replace existing file, or tap No, then either define a new filename or select another storage card.

A pop-up message will appear prior to Backup initialization.

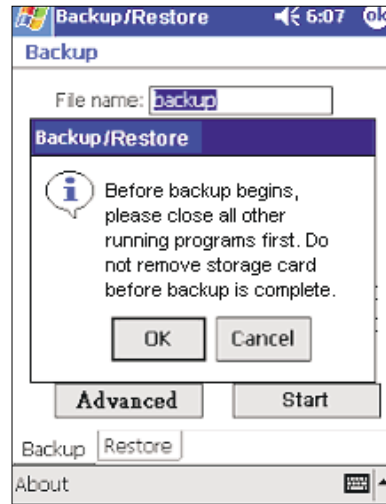

6 Tap OK.

During the backup process, a progress screen will appear displaying backup status.

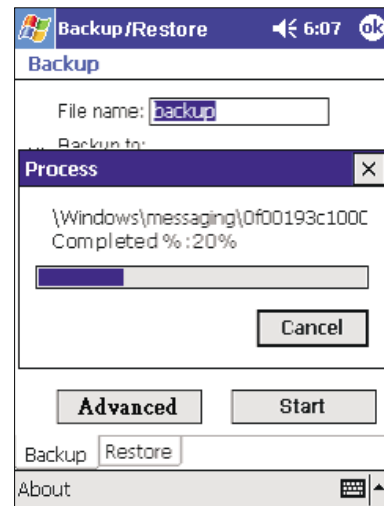

If a locked file is encountered during backup, a warning message will pop up.

6 Using third-party applications Backup/Restore

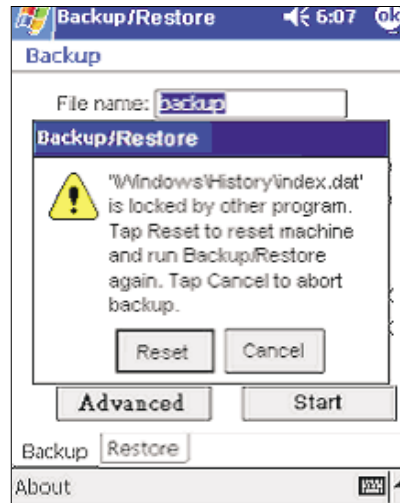

Tap Reset to restart your handheld, then launch Backup/Restore again. When the backup process is completed, a message box appears.

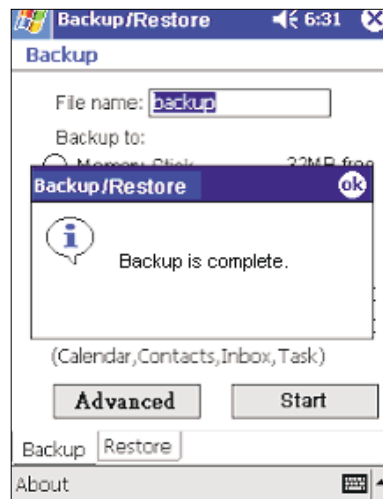

- 7 Tap ok.

Restore function

You can only restore backup files that are generated by Backup/Restore; file format is *.dbk.

To restore backup data

- 1 Close all running programs except for Backup/Restore.

6 Using third-party applications *Backup/Restore*

- 2 Select a storage card source (default: *Memory Stick*) from the 'Restore from' radio buttons.

A list of files contained in the selected storage card is displayed on the lower half of the screen. The filename, file size and creation of each backup file are shown.

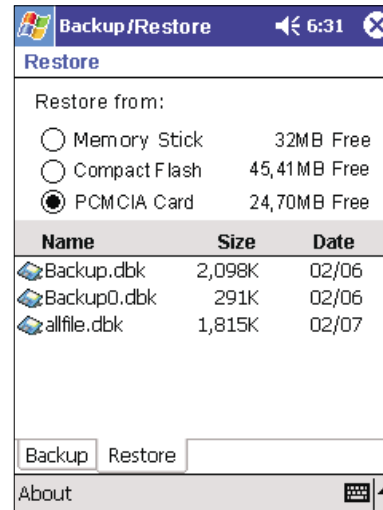

- 3 Tap a filename to select the file you wish to restore.

If a .dbk file generated by another application is selected, a warning message will pop up.

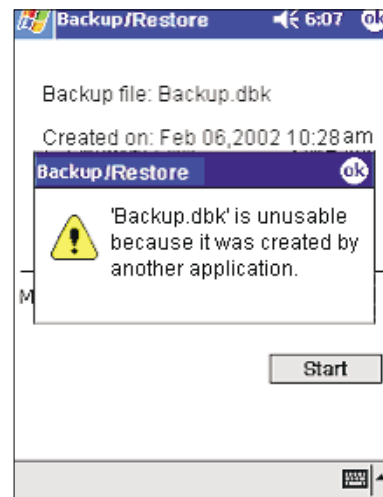

Tap ok, then select a .dbk file generated by Backup/Restore.

Once a valid .dbk file is selected, the window will shift to display related file information including:

- Backup file - filename of the selected .dbk file
- Created on - date when the selected .dbk file was created

6 Using third-party applications

Backup/Restore

- Backup option - mode used to generate the .dbk file
- Main memory free size - free space in your handheld's main memory. This should be bigger than the file size of the selected .dbk file for the restore process to proceed.



- 4 Tap Start to proceed with the restore process.
A pop-up message of restore reminders will appear.



- 5 Tap OK.
If a corrupted backup file (i.e., an error occurred during the backup process) is encountered during restore, a warning message will pop up.

6 Using third-party applications *Backup/Restore*

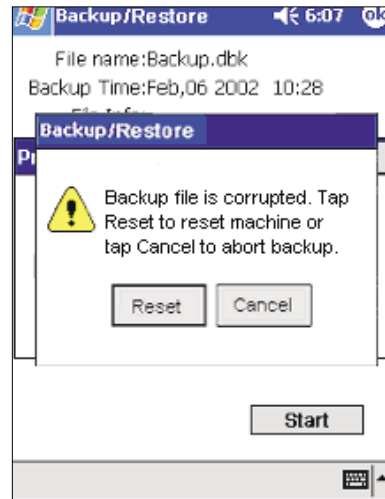

Tap Reset to restart your handheld, then relaunch Backup/Restore.
If a locked file is encountered during restore, a warning message will pop up.

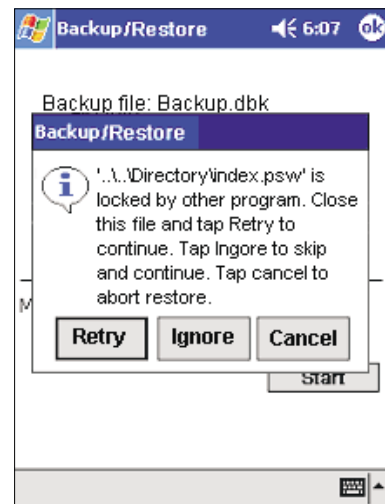

Do any of the following:

- Close the locked file then tap Retry to continue the restore process.
- Tap Ignore to skip the locked file and continue with the restore process.
- Tap Cancel to abort the whole restore process.

6 Using third-party applications

Backup/Restore

During the restore process, a progress screen will appear displaying restore status.

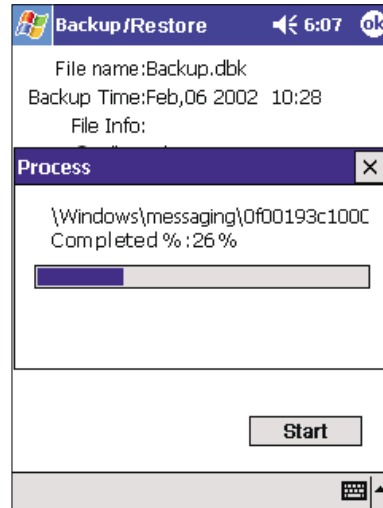

When the restore process is completed, a message box appears.

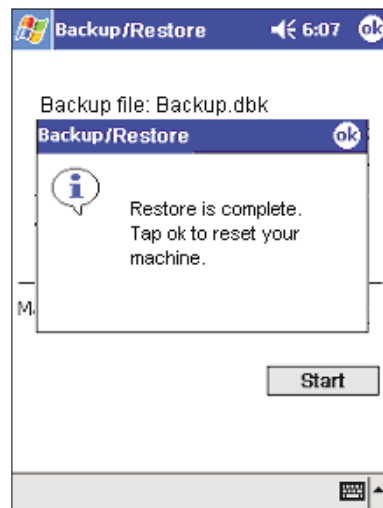

- 6 Tap ok.

Deleting a file from a storage card

To increase the size of available free space in a storage card, you can delete files that you no longer need.

- 1 Tap the Restore tab.
- 2 Select the storage card from which you want to delete a file.
- 3 From the list, tap a filename.

- 4 From the pop-up menu, tap Delete.
A message confirming deletion will appear.

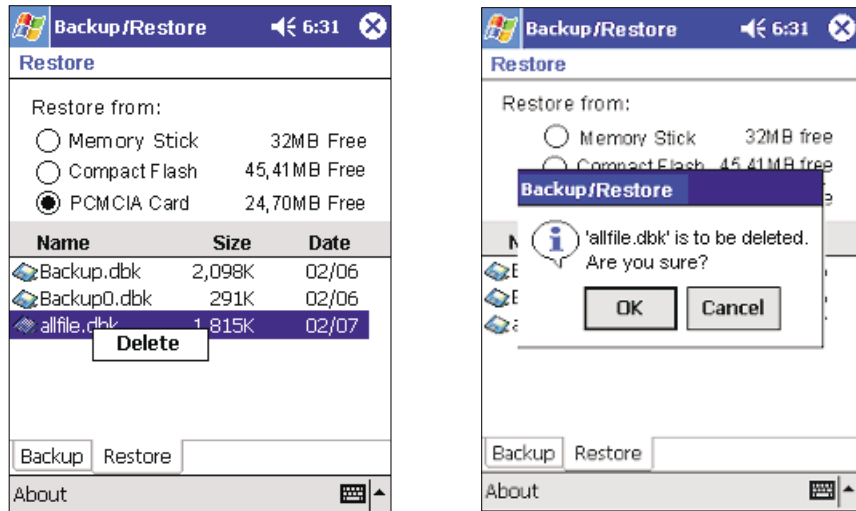

- 5 Tap OK.

IA Album LE

IA Album LE (Lite Edition) is a convenient image viewing tool for file management, browsing and viewing.

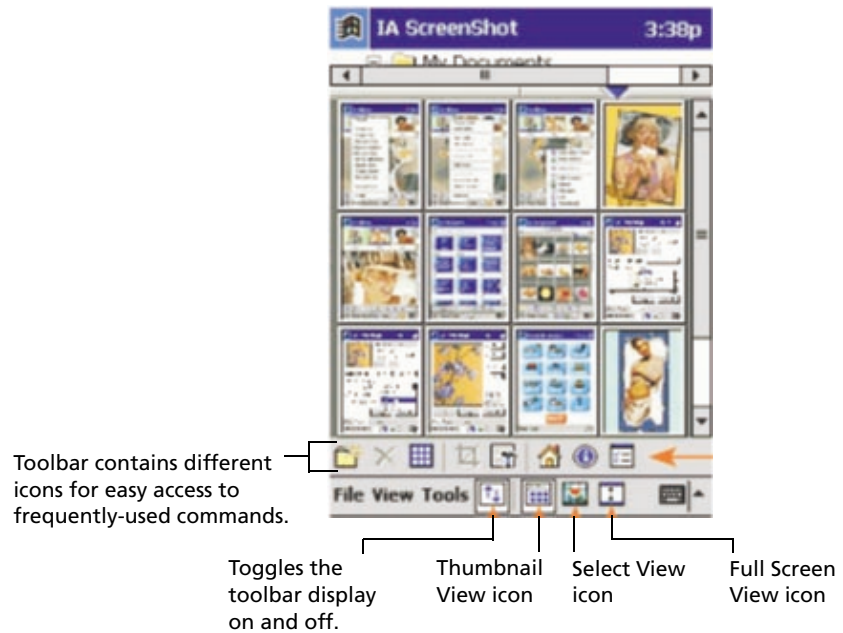

6 Using third-party applications

IA Album LE

Key features include:

- Built-in Screen Capture function with option to enable sound capture.
- Image viewing for BMP, 2BP, JPEG and GIF files.
- Image file and folder management capabilities.
View and manage any image on your handheld from any source (BMP, 2BP, JPEG, CMYK JPEG, or GIF format), whether or not they are screen-capture files created by IA Album LE.
- Image browsing and viewing modes include Thumbnail, Select, and Full Screen views.
- Optimise colours for 24-bit, 16-bit, 12-bit, 8-bit, and grayscale displays.
- Crop and Save function allows you to designate any portion of an image and then save that portion as a new file.
- Option to:
 - Select one of your hardware buttons to function as your Capture button, or specify a delay-time.
 - Convert an existing file to a different format (JPEG, GIF, or Bitmap) and resolution.
 - Save a captured screen image as a Bitmap, GIF, or JPEG file (desired resolution between 60 and 300 dpi).
- Specify a Home folder and then quick-jump to that folder or any other folder you have accessed during the current IA Album LE session.

IA Album LE menus

The IA Album LE's user interface has three menus on the command bar—File, Tools, and View.

File menu

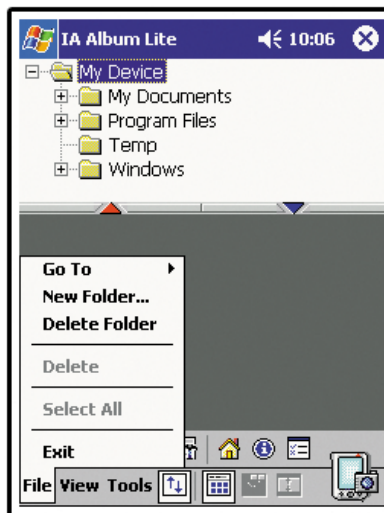

The File menu provides a convenient way to switch folders, create or delete folders, delete images, select all images in a folder, and quit the IA Album LE program.

Go To

This command provides a convenient way to switch folders. Any folders accessed during the current IA Album LE session will be available on the menu that appears when you tap Go To.

You can access the Go To menu by tapping its icon on the toolbar when in Thumbnail view. There is also a Home command on the GoTo menu which lets you access the set Home folder.

New Folder...

This command allows you to create a new folder on your handheld that you can use to store images.

- 1 Select the folder (in the upper pane) under which you want the new folder to reside.
- 2 Select the New Folder... command.
- 3 Enter the name for the new folder in the dialog box.

This command is also on the Toolbar, and on the pop-up menu that appears when you tap and hold in the folder pane while in Thumbnail View mode.

Delete Folder

This command allows you to delete an existing folder on your handheld.

- 1 Select the folder you want to delete.
- 2 Select Delete Folder from the File menu or the pop-up menu that appears when you tap-and-hold in the Folder pane when in Thumbnail View mode.

Delete

After you have selected one or more image files, this command becomes available. It allows you to permanently delete the file or files from the folder.

You can also select this command from the Toolbar, or from the pop-up menu that appears when you tap-and-hold in the lower pane when in Thumbnail view.

Select All

This command selects all images in the current folder. When in Thumbnail view, you can also use the Select All icon on the Toolbar.

If you wish to deselect all images after multiple images have been selected, simply tap anywhere within an empty portion of the Thumbnail image pane.

Exit

This command terminates the current IA Album LE session.

6 Using third-party applications

IA Album LE

View menu

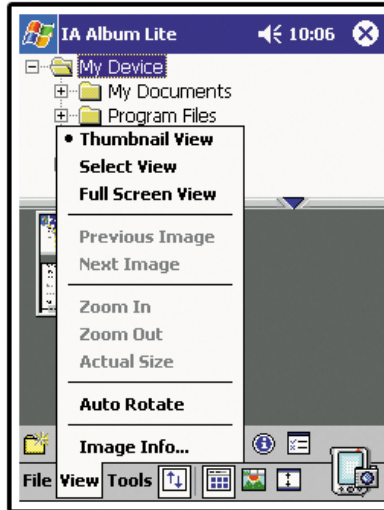

The View menu allows you to choose view modes, display your images in various ways such as zoom/rotate, and view data concerning the attributes of the images.

Thumbnail View

Switch to Thumbnail view by selecting Thumbnail View from the View menu, or by tapping its icon on the toolbar. In this view, images in the current folder are shown as thumbnails.



You can do the following in Thumbnail view:

- Tap the upward-pointing red triangle to display an additional row of thumbnail images. Conversely, each time you tap a downward-pointing blue triangle, a row of thumbnail images will be hidden.
- Tap the stylus on an image and then drag it to another position.

- Place your stylus within the edge at the far left or far right of the screen and then drag the stylus over the images to perform multiple selection useful in mass-editing such as Delete.
- Press your handheld's Directional pad right or down to select the next thumbnail image in the current folder. Pressing it left or up will select the previous thumbnail.
- Double-tap an image to switch to Select view, with the tapped thumbnail shown as the enlarged image.

Select View

Switch to Select View mode by doing any of the following:

- Double-tap an image while in Thumbnail View mode.
- Tap the Select View command from the View menu.
- Tap the Select View icon on the toolbar.
- Press the Directional pad on your handheld.

The selected image will be enlarged.

You can do the following in Select view:

- Press your stylus on an image that does not fit in the display area in its entirety and drag it in the desired direction to pan the image.
- Press your handheld's Directional pad right to display the next image in the current folder. Pressing it left will display the previous image.
- Press your handheld's Directional pad up to zoom in on the currently displayed image, or press down to zoom out.

A different toolbar appears in Select view. This toolbar provides convenient access to ten of the more common commands for Select view. To learn the function of any toolbar icon, press your stylus on the icon to view its tool tip.

Full Screen View

Activate the Full Screen view by doing any of the following:

- Select the Full Screen View command from the View menu.
- Tap the Full Screen View icon on the toolbar.
- Press in the center of your handheld's Directional pad.

In this view, the selected image is maximized so that the entire screen is used to display it. If you tap on an image while in Full Screen View, you will be returned to the previous view mode.

You can do the following in Full Screen view

- Press your handheld's Directional pad right to display the next image in the current folder. Pressing it left will display the previous image.
- Press your handheld's Directional pad up to zoom in on the currently displayed image, or press down to zoom out.

Previous/Next Image

These two commands (and the Previous Image icon on the toolbar) are only available in Select view. It selects the image previous to, or next to the current image (sequentially in the current folder) for display.

Zoom In/Zoom Out

This command (and the Zoom In icon—the left-most icon on the toolbar for Select View) is only available in Select view. Each time you select this command, the current image is incrementally magnified or reduced.

6 Using third-party applications

IA Album LE

Actual Size

This command (and the Actual Size icon on the toolbar) is only available in Select view. When you select this command, the current image will be displayed in its actual size; that is, a one-to-one pixel ratio.

Auto Rotate

If this command is selected, images will automatically be displayed in the most appropriate orientation on the screen. If active, a check mark will be shown to the left of the command name on the View menu.

Image Info...

Use this command to view various image attributes, folder information, and system resource usage status. To do so, select an image and then tap Image Info... on the View menu.

The Image Info screen consists of the Image, Size, Folder, and System tabs. When you finished viewing the info, click OK in the upper right corner of the screen.

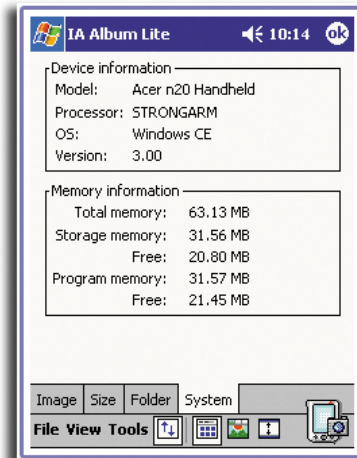
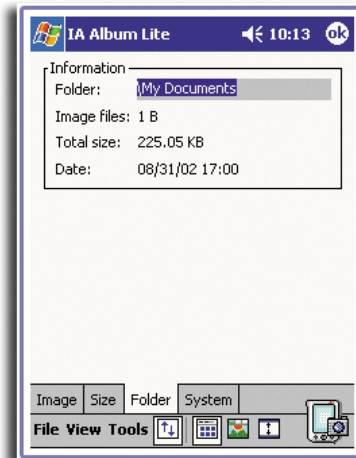
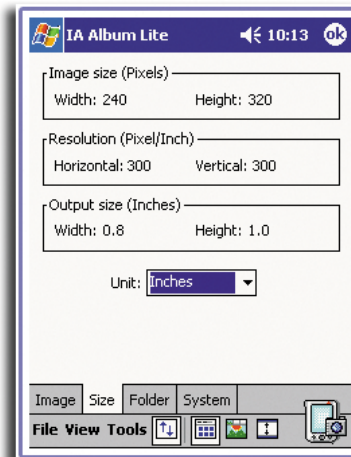
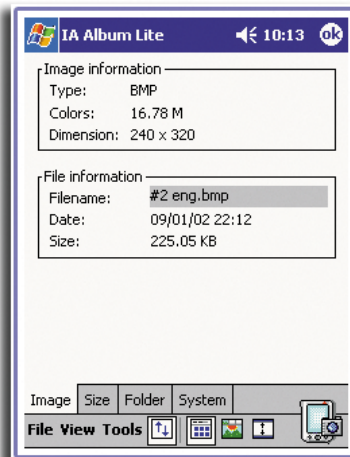

TIP: The Image Info feature is also available on the Toolbar in the form of an icon. When an image is being displayed in its Actual Size in Select View mode, the Image Info icon is shown as "1:1" instead of its standard appearance (the letter "i" inside a blue circle).

Tools menu

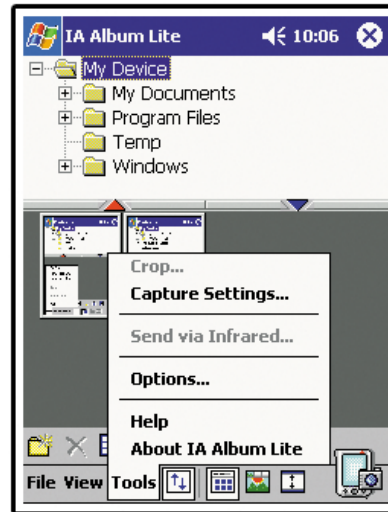

The Tools menu is where you set up your preferences for Screen Capture and general IA Album LE behaviors. It also allows you to crop an image, save it in a different format, send via infrared beaming, and access the main Help contents.

Crop...

This command allows you to specify a portion of a file and then save that portion of the file to a new individual file. You can also save a file to a different format and/or location. To do any of these options, select the image you want to crop (in either Thumbnail View or Select View) and then select Crop... from the Tools menu (or the Crop icon on the Toolbar). A thumbnail image will be shown in the Crop tab.

6 Using third-party applications

IA Album LE

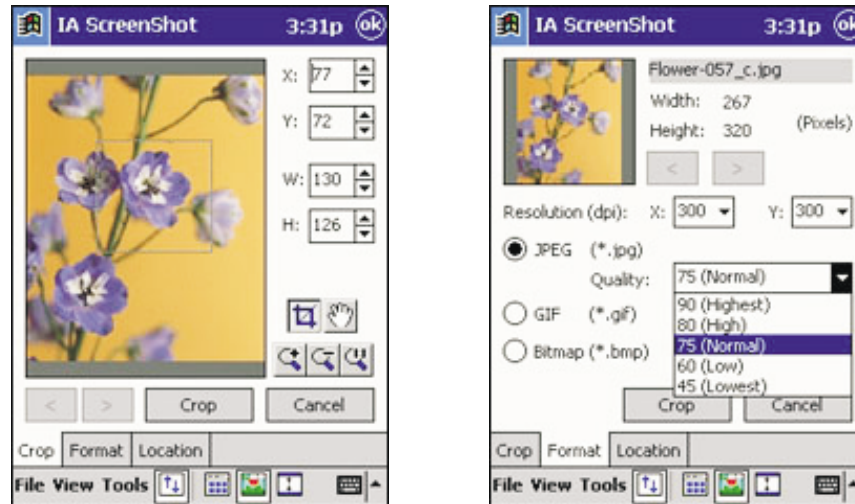

Crop tab

In the Crop tab, you can drag your stylus on the image to manually specify a square/rectangular area, or you can specify values in the X and Y (origin) and W and H (area) fields. After a Crop region has been defined, you can drag it around using your stylus. You can also Pan or Zoom In/Out using the icons in the Crop tab.

To save the cropped portion as a new file immediately to the same file type as the original, tap the Crop button. The default file-naming convention appends an underscore and a "c" (_c) prior to the extension, and places it in the current folder.

Format tab

Use the Format tab to save a cropped image to a different file type and/or resolution. You can save the file in .jpeg, .gif, or .bmp format.

Depending on which format you choose, Quality and Color choices will also be available. You also have the option to save the image at a different resolution.

Location tab

Use the Location tab to save a cropped image under a different folder. You also have the option to change the filename.

Capture Settings...

This command allows you to set any of your handheld's hardware buttons to act as a "capture" button. By simply pressing the capture button that you have designated, whatever is currently displayed on your handheld screen will be saved as an image file.

Setting and configuring a "capture" button

- 1 Tap Capture Settings... on the Tools menu, or its icon on the toolbar.

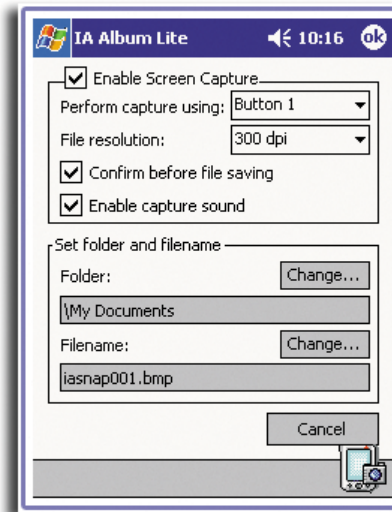

- 2 Make sure the Enable Screen Capture check box is checked.
 - 3 In the Perform capture using field, select the desired button or time-delay from the drop-down list.

If you select a button, that button on your handheld will be used as your Screen Capture button. The buttons in the drop-down list refer to the hardware buttons on your handheld.

If you select a Delay Time value from the list, the screen capture will take place after the chosen number of seconds passes.
 - 4 In the File resolution field, you can select a different predefined resolution from the drop-down list box.

Your screen captures will be saved to the resolution you choose in this field. However, you cannot change the resolution if you choose to save screen captures in the GIF format.
 - 5 Choose whether or not you want a confirmation screen to appear each time you create a screen-capture file.

By default, the Confirm before file saving check box is selected. If you remove the check from this check box, the screen capture process will take place immediately with no confirmation.
 - 6 Choose whether or not you want to trigger a sound each time you perform a screen capture. If so, check the Enable capture sound check box.
 - 7 If you want to specify a different folder in which to save the screen-capture file, tap the Change... button next to the Folder field and select the desired folder in the screen that appears.
-
- NOTE:** In the bottom half of the screen, the default location for the screen-capture file—My Documents folder is automatically specified.
-
- 8 If you want to specify a different filename prefix or suffix, tap the Change... button next to the Filename field and make the desired change.

6 Using third-party applications

IA Album LE

NOTE: In the bottom half of the screen, a default filename for the screen-capture file is automatically specified. By default, the name iasnap001 will be given to the first screen-capture file, the next screen-capture file would be sequentially named iasnap002, etc.

- 9 Specify the desired format in the Select the capture file format field. When finished, tap OK in the upper right corner. This will return you to the previous screen

By default, screen-capture files will be saved in the Bitmap (.bmp) format. You can optionally choose to save screen-capture files in the .jpeg or .gif format.

- JPEG format is suitable for saving a screen on which a photo or video is displayed.
- GIF can produce the smallest file size when used to store regular screen shots.

- 10 Tap OK.

Capturing screens

As long as the Enable Screen Capture check box is selected, and IA Album LE is running (even in the background), you can perform a screen capture anytime you want by simply pressing the "capture" button you have specified. When IA Album LE is not running, the original function of that handheld button will be restored.

Send via Infrared...

This command allows you to send a selected file to another IR-enabled device via infrared beaming, without having to leave the IA Album LE screen.

After the receiving device has started its "Receive via Infrared" process, tap Send via Infrared.... You will have approximately 30 seconds in which to line up the infrared port of your handheld with the infrared port of the receiving device.

Options...

Tapping Options... on the Tools menu, or its icon on the Toolbar, opens a screen that contains settings for colour dithering, auto-rotation, size of thumbnail images, and your Home folder.

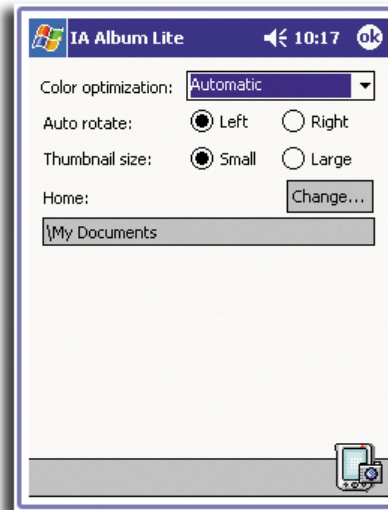

- Color optimization

The choices in the Color optimization drop-down list are related to the output fidelity of the images displayed on your handheld. If you have an 8-, 12-, or 16-bit colour handheld, you should select the appropriate item from the list so that IA Album LE can map the images to the corresponding colour resolution. This will enable IA Album LE to perform optimum dithering in the event that an image contains a colour that is not supported by your handheld screen.

The default setting is Automatic meaning IA Album LE will do its best to detect your handheld's display capabilities and automatically optimise colours. If the None setting is enabled, no colour optimisation will be performed meaning the image will be displayed in its original form.

- Auto rotate

The Auto rotate function controls whether the intelligent 90-degree rotation will occur to the Left or to the Right when in Full Screen view. This function is activated when the Auto Rotate command on the View menu is selected.

- Thumbnail size

The Thumbnail Size function controls whether thumbnail images are displayed in Large or Small size, both in Thumbnail and Select views. Default setting is Small.

- Home

By default, the Home folder is set to the \My Documents folder. You can change the Home folder to any folder. Follow the steps below:

- 1 Select Options... from the Tools menu.
- 2 Tap the Change... button in the Home field.

Acrobat Reader for Pocket PC

Acrobat® Reader® for Pocket PC® lets you view Adobe Portable Document Format (PDF) files from your handheld. This application includes two components:

- The ActiveSync® filter runs on the Windows platform. It prepares untagged Adobe PDF files and transports them to your handheld.
- The Reader is an application in your handheld designed to accommodate the characteristics of small-screen devices.

Acrobat Reader for Pocket PC allows you to view Adobe PDF files in two modes:

- View the Adobe PDF file exactly as intended
- View a tagged Adobe PDF file in a reflowed format. This provides the best reading experience on your handheld because text and images are shown in a 'fit-the-screen' mode.

Refer to (<http://www.adobe.com/products/acrobat/readerforppc.html/>) for more information.

PocketTV Enterprise Edition

PocketTV™ Enterprise Edition allows you to play back standard MPEG-1 video files (i.e. extension .mpeg, .mpe or .mpg) as well as MPEG-1 video elementary streams (i.e. video only, no audio), with extension .m1v.

The program also supports .m1u files (MPEG-1 URL). These are text files that contain the URL of an MPEG file. These files can be used to trigger streaming from web pages. For more information, see (<http://www.pockettv.com/html.html/>).

NOTE: PocketTV can be launched from the File Explorer, by tapping an MPEG file.

For more information on PocketTV usage and troubleshooting, see (<http://www.mpegv.com/wince/pockettv/faq.html/>).

Command bar

The Command bar contains the usual media player commands including:

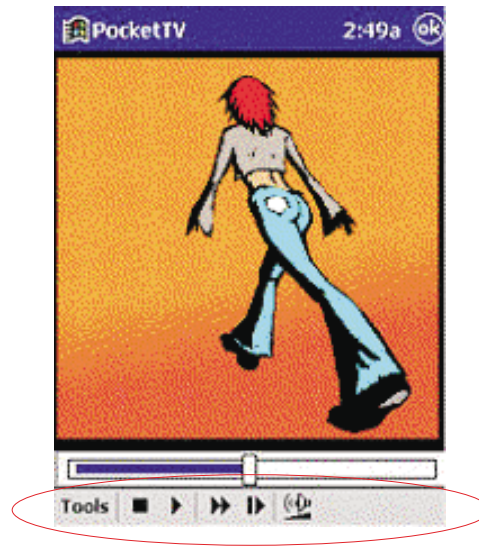

- Stop
- Play
- Pause
- Step
- Fast-forward
- Volume control
- Mute
- Repeat (loop)
- Open file

- Fullscreen/Landscape switch
PocketTV automatically detects the screen orientation when a third-party Landscape driver is used (JSLandscape or Nyditot Virtual Display).

TIP: You can also tap on the video to switch between normal mode and Fullscreen/Landscape mode.

Seek/Progress bar

Allows you to control display pace and shows the playback progress.



Status bar

Shows time information (estimated time elapsed, estimated total play time), fps indicator (actual frames-per-second) and bit-rate indicator.



Tools menu

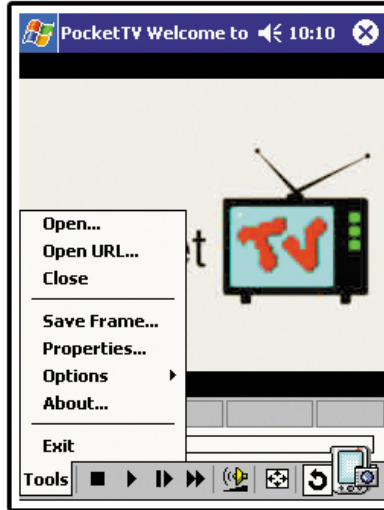

Includes the following commands:

- **Open** Select a file to open.
There are two possible ways to open a file, depending on whether the option *Options > Files > Open With tGetFile* is selected or not.
If selected, you can open a file located anywhere; otherwise it uses the standard Microsoft dialog which only shows the files located in 'My Documents' and in one level of subfolders.
- **Open URL** Specify an http URL for streaming.
Built-in streaming protocols include http and ftp.
- **Save Frame** Capture and save the current frame.
The frame is saved in RGB 'Targa' format and can be viewed or converted using the popular PQView image viewer.
- **Properties** Show the file parameters.
- **Options** Refer to the following subsection for details on this Tools command.
- **About** Show copyright and registration information.
- **Exit** Terminate the application.
This is different from the (X) 'Smart Minimize' button, which merely deactivates PocketTV and pushes it back to the background.

Options menu command

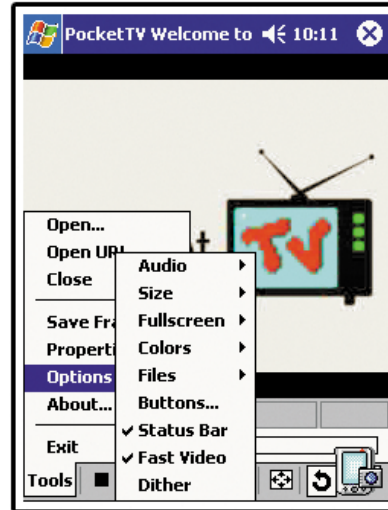

Some menu commands under Options also have their own set of sub-commands.

- **Audio** Audio Channels: Stereo, Mono (left), Mono (right)
 Audio Quality: High, Medium, Low
 Swap Left/Right
- **Size** Auto - fit screen if video is larger than screen
 Nominal - fit screen if video is smaller than screen
 Fit screen
- **Fullscreen** 90 deg Left
 90 deg Right
 Auto at Play - switch to Fullscreen when it starts playing
 Always when Playing - links play mode with Fullscreen
 Video Output: Normal, Voyager VGA, Presenter-to-go
 VGA
- **Color** Adjust - opens the Color Adjustment dialog.
 You can adjust the Brightness (Gamma), Contrast, Color
 (saturation) and colour balance (red, green and blue
 gamma).
 There are options to set each individual value to neutral
 or default (i.e. adjusted for optimum quality).

NOTE: The Default and Neutral options act on all the values.

6 Using third-party applications

PocketTV Enterprise Edition

- **Files**

Play at Open - file is in automatic playback mode when opened.

Microdrive - additional buffering is use to reduce battery usage when playing from a hard drive or Microdrive.

Open with tGetFile - change the format of the Open File dialog.

Save with tGetFile - change the format of the Save Frame dialog.

Remember Last - last opened file before exiting PocketTV is automatically displayed on the next session.

File Association - check file association.

NOTE: If a PocketTV file association was modified by another application, you have the option to restore it.

7 Using expansion features

The slim and lightweight design of your Acer n20 belies the impressive expansion features that it is capable of. These expansion features include the following:

- Integrated *Memory Stick* slot
- Acer Versatile Connector
- Expansion sleeve (optional)

These expansion features allow you to:

- Install additional applications
- Increase system memory
- Perform backup procedures
- Use a variety of peripheral devices
- Connect to the Internet or to a network

NOTE: Before using any peripheral device with your handheld, refer to the documentation that accompany each device for information on how to install and operate it.

Memory Stick

On the top of your handheld is a *Memory Stick* slot. This allows you to expand your handheld memory and perform data backup.

Refer to "Top view" on page 6 for the location of the *Memory Stick* slot.

For instructions on how to use a *Memory Stick* to perform data backup, refer to "Backup/Restore" on page 64.

To learn more about *Memory Stick*, please go to (<http://www.memorystick.org/>).

Inserting a *Memory Stick*

- 1 Hold your handheld securely.

7 Using expansion features

Memory Stick

- 2 Insert the *Memory Stick* into the *Memory Stick* slot.



- 3 Push the card into the slot using your finger until you feel the card lock and hear an audible system sound; this will signal that the card is already properly seated within the slot.

Removing a *Memory Stick*

- 1 Hold your handheld securely.
- 2 Release the card from the slot by using your finger to push against the top of the card, as if you were pushing it further into the slot **(a)**. An audible system sound will signal that the card has been released.
- 3 Gently remove the card from the slot **(b)**.



Acer Versatile Connector

Acer has adopted the use of a standard connector interface—the Acer Versatile Connector, on its handheld line. This interface allows you to easily attach and use peripheral hardware devices as a modem, a portable keyboard or a Global Positioning System (GPS) receiver. You can also use the Versatile Connector to take advantage of the existing line of accessories available for the Acer s10 Handheld series including the Travel Charger and the USB Sync Charge Cable.

Refer to "Front panel" on page 2 for the location of the Acer Versatile Connector.

Expansion sleeve

The expansion sleeve is an optional accessory designed for users who demand more features and functions. It combines the ultimate flexibility in expansion, increase battery capacity, and adds more functionality, all in a simple and portable design.

The illustration below shows the components of the expansion sleeve.

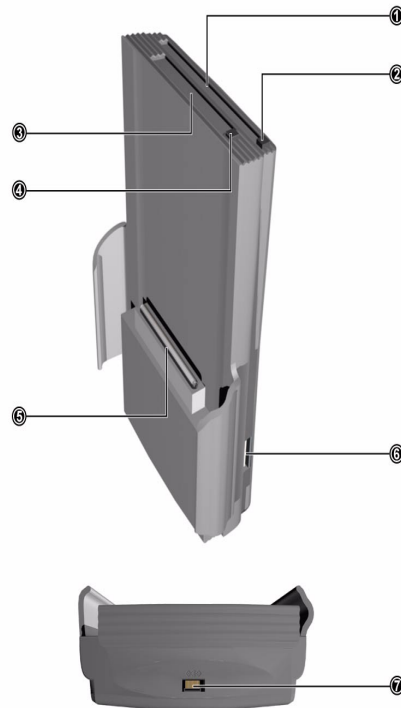

No.	Component	Usage
1	PC Card Type II slot	Accepts PC Card-based peripheral devices.
2	PC Card Type II slot eject button	Press to pop-out any installed PC Card-based device.

7 Using expansion features

Expansion sleeve

No.	Component	Usage
3	CompactFlash Type II slot	Accepts CompactFlash-based peripheral devices.
4	CompactFlash Type II slot eject button	Press to pop-out any installed CompactFlash-based device.
5	100-pin expansion slot	Connects the expansion sleeve to your handheld.
6	USB host connector	Accepts USB peripheral devices.
7	Power socket	Connects to the AC adapter to provide external power supply to the system

Attaching your Acer n20 to the expansion sleeve

- 1 Detach the removable battery pack from your handheld (**a**).

Refer to "To uninstall the battery pack" on page 9.

IMPORTANT: After removing the battery pack, you have about 30 minutes to attach the expansion sleeve and turn the handheld back on, otherwise you risk losing all data on the internal memory of your handheld.

- 2 Align the handheld's rear panel to the expansion sleeve then, slide it in through the sleeve's arms (**b**).
- 3 Gently push your handheld downward until you feel it lock.



- 4 Slide the battery release switch on the handheld to Lock position.

Using the expansion sleeve

Both the CompactFlash and PC Card slots are flexible expansion features that allow you to use a wide range of peripheral devices with your handheld. These may include:

- Hard drives
- Memory cards
- VGA (Video Graphics Array) cards
- Cellular phone interface
- GPS (Global Positioning System) cards
- Modem cards
- Modem and Ethernet combination cards
- 100 Mbps Ethernet adapters
- Ethernet LAN adapters
- Infrared wireless LAN adapters

These two expansion slots also allow you to use a wide selection of products for notebook computers making your handheld an ideal mobile buddy for your laptop computer.

For instructions on how to use a CompactFlash card or a PC Card to perform data backup, refer to "Backup/Restore" on page 64.

To learn more about CompactFlash and PC Card, refer to (<http://www.compactflash.org/>) and (<http://www.pc-card.com/>) respectively.

The extra capacity battery function of the expansion sleeve system provides your handheld with increased battery capacity to cope up with the more power-demanding applications.

With the standard USB host connector you can easily attach USB peripheral devices to your handheld without consuming precious system resources. The expansion sleeve can readily support USB keyboards. For other USB devices, operation will depend on driver availability.

Inserting a CompactFlash card

- 1 Hold your handheld securely.
- 2 Insert the CompactFlash card into its corresponding slot on the expansion sleeve.



7 Using expansion features

Expansion sleeve

- 3 Push the card into the slot using your finger until you feel the card lock.

Removing a CompactFlash card

- 1 Hold your handheld securely.
- 2 Press the slot eject button to pop out the card **(a)**; then gently remove it from the slot **(b)**.



Inserting a PC Card

- 1 Hold your handheld securely.
- 2 Insert the PC Card into its corresponding slot on the expansion sleeve.



- 3 Push the card into the slot using your finger until you feel the card lock.

Removing a PC Card

- 1 Hold your handheld securely.
- 2 Press the slot eject button to pop out the card **(a)**; then gently remove it from the slot **(b)**.



7 Using expansion features

Expansion sleeve

8 Exchanging and updating data using ActiveSync®

Using ActiveSync®, you can synchronise information in Microsoft Outlook or Microsoft Exchange on your computer with your handheld. You can also synchronise this information directly with a Microsoft Exchange server. Each time you synchronise, ActiveSync compares the changes you made on your handheld and computer or server and updates both locations with the latest information. For example:

- Keep Pocket Outlook data up-to-date by synchronising your handheld with the Microsoft Outlook data on your computer.
- Synchronise Microsoft Word and Microsoft Excel files between your handheld and your computer. Files are automatically converted to the correct format.

By default, ActiveSync does not automatically synchronise all types of information. Use ActiveSync options to turn synchronisation on and off for specific information types.

NOTE: If you have a wireless LAN card, you can synchronise remotely from your handheld. For the Acer n20w model, you can use the built-in IEEE 802.11b WLAN adapter.

For information on using ActiveSync, see ActiveSync Help on the your computer.

You can also use ActiveSync to:

- Back up and restore your handheld data.
- Copy (rather than synchronise) files between your handheld and your computer.
- Control when synchronisation occurs by selecting a synchronisation mode.
For example, you can synchronise continually while connected to your computer or only when you choose the synchronise command.
- Select which information types are synchronised and control how much data is synchronised.
For example, you can choose how many weeks of past appointments you want synchronised.

Before you begin synchronisation, install ActiveSync on your computer from the Acer n20 Handheld Companion CD.

NOTE: ActiveSync is already installed on your handheld.

For instructions on installing ActiveSync, see "Installing the Microsoft® ActiveSync® software" on page 7 or you could refer to the Just for Starters... poster included in the package contents.

For detailed information about using ActiveSync on your computer, start ActiveSync on your computer, and then see ActiveSync Help.

8 Exchanging and updating data using ActiveSync®

To open ActiveSync on your handheld

- Tap , and then tap ActiveSync.

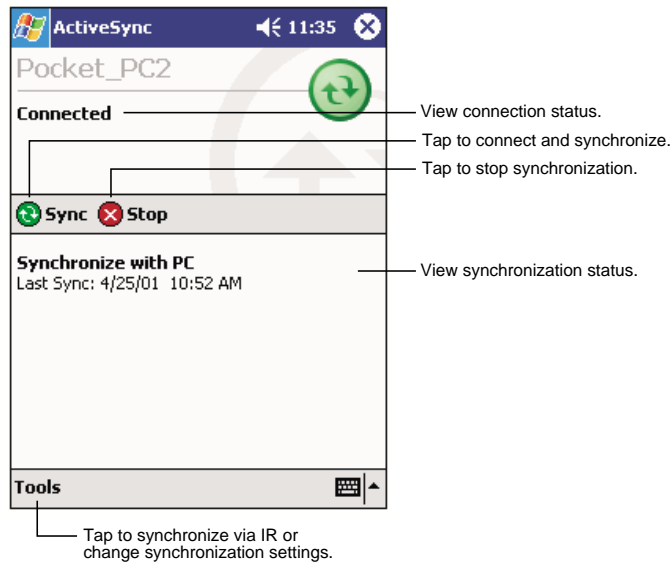

To remotely synchronise your handheld

- 1 Tap , and then ActiveSync.
- 2 In the Tools menu, tap Options.
- 3 In the PC tab, select Include PC when synchronising remotely then select your computer's name.

Remote synchronisation with a computer will work only if you have set up a partnership with that computer through ActiveSync and have set ActiveSync to allow remote connections. Other restrictions apply.

For more information on synchronising remotely, see ActiveSync Help on the your computer.

9 Getting connected

You can use your handheld to exchange information with other mobile devices and connect to your computer, a network, or the Internet. You have the following connection options:

- Use the infrared (IR) port on your handheld to send and receive files from another IR-enabled device.
- Use the built-in IEEE 802.11b WLAN adapter to connect to an existing IEEE 802.11b wireless network (applicable only to the Acer n20w handheld model).
- Connect to your Internet service provider (ISP). Once connected, you can send and receive email messages by using Inbox and view Web or WAP pages by using Microsoft® Pocket Internet Explorer.
The communication software for creating an ISP connection is already installed on your handheld. Your service provider will provide software needed to install other services, such as paging and fax services.
- Connect to the network at your company or organisation where you work. Once connected, you can send and receive email messages by using Inbox, view Web or WAP pages by using Microsoft® Pocket Internet Explorer, and synchronise with your computer.
- Connect to your computer to synchronise remotely. Once connected, you can synchronise information such as your Pocket Outlook information.

Infrared communication

Using infrared, you can send and receive information, such as contacts and appointments from another IR-enabled device.

Refer to "Front view" on page 3 for the location of your handheld's IR port.

Sending information

- 1 Switch to the program where you created the item you want to send and locate the item in the list.
- 2 Align the IR port of your handheld with that of the IR-enabled device so that they are unobstructed and within a close range.
- 3 Tap and hold the item, and then tap Beam Item on the pop-up menu.

-or-

Send items (but not folders) using File Explorer.

- Tap and hold the item you want to send and then tap Beam File on the pop-up menu.

9 Getting connected

Wireless communication

Receiving information

- 1 Align the IR port of your handheld with that of the IR-enabled device so that they are unobstructed and within a close range.



- 2 Have the owner of the other device send the information to you. Your handheld will automatically receive it.



Wireless communication

Applicable only to the Acer n20w model, this feature uses a built-in IEEE 802.11b WLAN adapter to connect to an existing IEEE 802.11b wireless network. This feature provides you with an Internet experience that is completely mobile to meet your fast-paced lifestyle, and with a high-speed transmission rate of up to 11 Mbps you're sure to be always wired to the information highway.

Activating the wireless feature

- 1 Tap , Settings.
- 2 Tap the System tab, then the Wireless LAN Utility icon.

Configuring the wireless settings

To view and modify the IP address and server-related settings:

- 1 Tap , Settings.
- 2 Tap the Connections tab, then the Network Adapters icon.
- 3 Select IEEE 802.11b WLAN Adapter from the list, then tap the Properties button.

IP Address page

Use this page to view and edit the IP address, the subnet mask and the default gateway settings.



You can use a server-assigned IP address or you can set a specific one.

- **IP address (Internet Protocol address)**
This is a numeric address that the domain name server translates into a domain name. Each node on the IP network has a unique IP address.
- **Subnet mask**
A number used to identify a sub-network when multiple networks share a common IP address.
- **Default gateway**
This is a device used to forward IP packets to and from a remote destination.

Name Servers page

Use this page to view and edit the DNS, Alt DNS, WINS and Alt WINS settings.

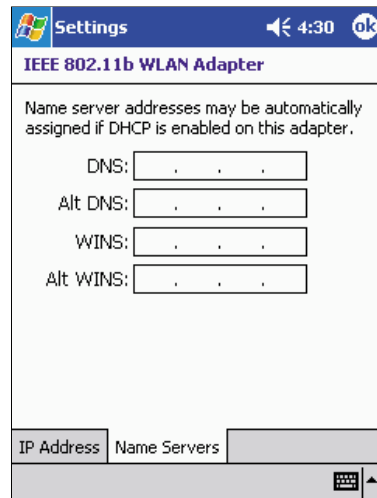

- **DNS (Domain Name System)**
This is a database system that translates IP addresses to domain names. For example, an IP address like 232.245.021.54 can correspond to the domain name <http://jtl.com>. This system is also used to control Internet email delivery.
- **Alt DNS (Alternative DNS)**
Used to substitute the main DNS when necessary.
- **WINS (Windows™ Internet Naming Service)**
This service has two functions. First, the Microsoft® Net BIO name server eliminates the broadcasts needed to resolve the computer names to IP addresses by providing a cache or database of translations. The other function sets the IP address of the host computer you used when you set up the wireless utility for wireless ActiveSync operation.

NOTE: You need to set the IP address of the host computer to perform wireless synchronisation between your handheld and your host computer.

- **Alt WINS (Alternative WINS)**
Used to substitute the main WINS when necessary.

Configuring the WLAN utility

- 1 Tap , Settings.
- 2 Tap the System tab, then the WLAN icon.

Link page

Use this page to view the SSID, Channel, TxRate, BSSID, IP Address, Subnet Mask and Gateway settings.

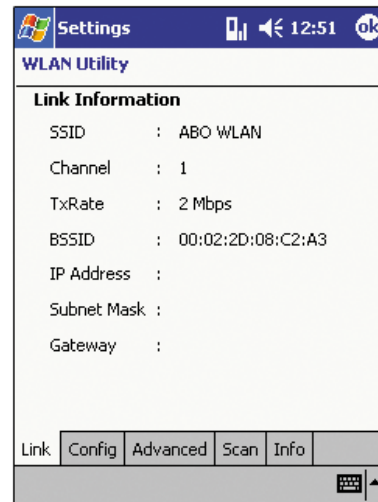

- **SSID (Service Set Identifier)**
This is a unique case-sensitive name of up to 32 characters shared among all devices sharing a common wireless network. The name value is set in Scan page with the default value being 'ANY'.
- **Channel**
Displays the current channel used for Access Point or 802.11 Ad Hoc stations.
- **TxRate**
Displays the current data transmission rate.
- **BSSID (Basic SSID)**
Displays the current BSSID selected for Access Point or 802.11 Ad Hoc networks. When your handheld is not connected to a wireless network, the BSSID value would be 'Non-associated'. You can view the BSSID list in the Scan page.
- **IP Address**
Displays the current IP address.
- **Subnet Mask**
Displays the current subnet mask.
- **Gateway**
Displays the IP address of the current gateway.

Configuration page

Use this page to set the Mode, SSID, Channel and Country settings, and to view the Link Quality indicator.



- **Mode**
Select the operating mode.
 - Infrastructure - This is the default mode. It allows transmission and reception of data to and from an Access Point (AP) cell. It also enables roaming between AP cells in the network.
 - 801.11 Ad Hoc - This mode allows the formation of a local network where adapters using a shared SSID communicate peer-to-peer without going through Access Points.
- **SSID**
This is a unique case-sensitive name of up to 32 characters shared among all devices sharing a common wireless network. You will be able to connect to an Access Point with the same SSID.
When operating under the 801.11 Ad Hoc mode, the SSID must be the same among stations so that computers can communicate properly within the LAN.
- **Channel**
Under the 801.11 Ad Hoc mode, the first station forms the 801.11 Ad Hoc network by selecting the initial SSID and channel. Other stations will only need to have the same SSID to join the network.
- **Country**
Select the country where you are located. Different countries have different wireless regulations.
- **Rescan.**
Tap this button to search for the nearest Access Point.
- **Radio On/Off:**
Tap this button to turn your adapter's radio on or off.

- **Link Quality.**
This icon indicates the clarity of your handheld's connection to the Access Point.

Advanced page

Use this page to view and set the WEP, Transmission Rate, and Power Saving Mode settings.

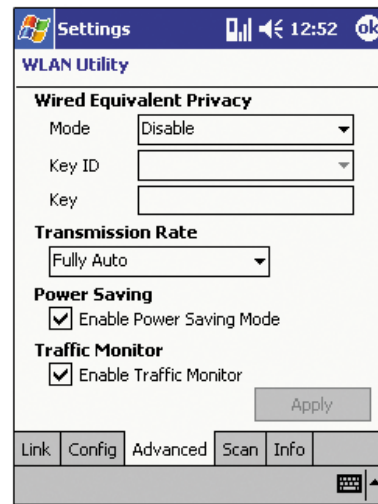

- **WEP (Wired Equivalent Privacy)**
Select the WEP mode, key ID and key.
Mode options:
 - Disable - This is the default mode. Choose this mode when security issue is of no concern. This mode increases the rate of data transmission.
 - 64 bits (ASCII)
 - 128 bits (ASCII)
 - 64 bits (HEX)
 - 128 bits (HEX)Key ID options:
When you enable one of the ASCII or HEX WEP modes, the Key ID setting would automatically be enabled as well. You must choose 'Key ID' for connection with an AP or peer site station. You can choose 'Key 1' to 'Key 4' for your personal use.
Key options:
When you enable one of the ASCII or HEX WEP modes, the Key setting would automatically be enabled as well. You have to enter the WEP key characters manually.
 - 64 bits (ASCII) - requires 5 ASCII characters with no limitation
 - 128 bits (ASCII) - requires 13 ASCII characters with no limitation

9 Getting connected

Wireless communication

- 64 bits (HEX) - requires 10 hexadecimal numbers with an upper limit of 10 hexadecimal value from 0-9 and from (A)-(F).
- 128 bits (HEX) - requires 26 hexadecimal values with an upper limit of 26 hexadecimal numbers from 0-9 and from (A)-(F).

NOTE: For HEX keys, when you enter an out-of-range character, you will be prompted to enter the correct character.

- Transmission Rate
Select a transmission rate option.
 - Fixed 1 Mbps
 - Fixed 2 Mbps
 - Fixed 5.5 Mbps
 - Fixed 11 Mbps
 - Auto Select 1 or 2 Mbps
 - Fully Auto - Choose this option to automatically adjust the transfer speed (recommended).
- Power Saving mode
Select or clear the check box to enable or disable the power saving mode.
When you are in the 802.11 Ad Hoc mode, you cannot enable the power saving mode.

Scan page

Use this page to scan and select available Access Point and 802.11 Ad Hoc networks.

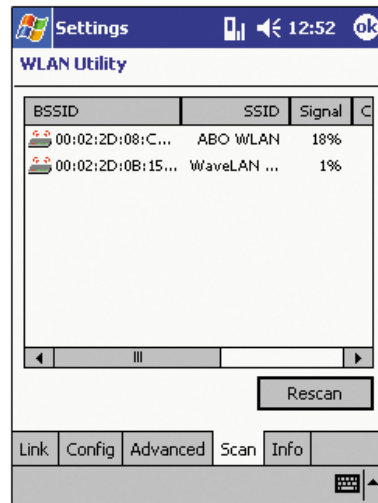

- Rescan
Tap this button to view all available 802.11 networks.

- BSSID/SSID

A wireless network is identified by its BSSID and SSID. Double-tap an item in the BSSID column to select the AP/801.11 Ad Hoc network you want to connect to. The Link page of the selected network will be displayed.

When operating under the 801.11 Ad Hoc mode, the SSID must be the same among stations so that computers can communicate properly within the LAN.

- Signal

Percentage values indicate the signal strength of AP.

- Channel

Indicates which channel is set to be used by the network.

- Encryption

Indicates whether encryption is enabled or disabled in the selected network.

Info page

Use this page to view the MAC address and version information of your handheld's wireless utility.

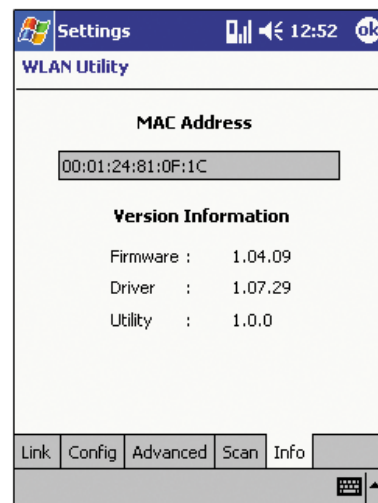

- MAC (Media Access Control) Address

This refers to the physical address of a device connected to a network expressed as a 48-bit hexadecimal number.

- Version Information

Includes version information for your handheld's firmware, driver and wireless utility.

Connecting to the Internet

You can connect to your ISP, and use the connection to send and receive email messages and view Web or WAP pages.

You can connect to the Internet in one of two ways:

- Create a modem connection.
If this is the method you want to use, see "To create a modem connection to an ISP" later on this page.
- Use an Ethernet card and a net tap to connect to the network.
If this is the method you want to use, see "To create an Ethernet connection to an ISP" on page 111.
You can use either an Ethernet PC Card or a CompactFlash Ethernet card. Either way, you will need to use an expansion sleeve (optional accessory) to make the connection.

To create a modem connection to an ISP

- 1 Obtain the following information from your ISP:
 - ISP dial-up access telephone number
 - User name and password
Some ISPs require information in front of the user name, such as MSN/username.
 - TCP/IP settings
- 2 If your handheld does not have a built-in modem, install a modem card, or use a NULL modem cable and appropriate adapters to connect an external modem to your handheld through the Versatile Connector.
- 3 Tap  and then Settings.
- 4 In the Connections tab, tap Connections.
- 5 Under The Internet settings, select Internet Settings and tap Modify.
- 6 In the Modem tab, tap New.
- 7 Enter a name for the connection, such as "ISP Connection".
- 8 In the Select a modem list, select your modem type.
If your modem type does not appear, try re-inserting the modem card. If you are using an external modem that is connected to your handheld with a cable, select Hayes Compatible on COM1.
- 9 You need not change any settings in Advanced. Most ISPs now use a dynamically-assigned address. If the ISP you are connecting to does not use a dynamically-assigned address, tap Advanced and then the TCP/IP tab, and enter the address. When finished, tap OK and then Next.
- 10 Enter the access phone number, and tap Next.
- 11 Select other desired options, and tap Finish.
- 12 In the Dialing Locations tab, specify your current location and phone type (most phone lines are tone). These settings will apply to all connections you create

To create an Ethernet connection to an ISP

You do not need to create a new connection on your handheld. Instead, you must purchase and configure an Ethernet card that is compatible with your handheld.

- 1 Obtain the following information from your ISP:

- User name and password
- Domain name

- 2 Connect the expansion sleeve to your handheld.

- 3 Insert the Ethernet card into the appropriate slot in the expansion sleeve.

The first time you insert the card, Network Settings will appear automatically so that you can configure the Ethernet card. Most networks use DHCP, so you need not change these settings unless your network administrator instructs you to do so.

NOTE: If Network Settings does not appear or you wish to change settings later, tap  and then Settings. On the Connections tab, tap Network Adapters, tap the adapter you want to change, and then tap Properties.

- 4 Tap OK.

- 5 Connect the Ethernet card to the network by using a network cable.

NOTE: For instructions on inserting and using the Ethernet card, see the documentation that came with the card.

- 6 Tap , Settings, Connections tab, and then Connections.

- 7 From the My network card connects to list, select Internet.

Connecting to a network

If you have access to a network at work, you can send email messages, view Intranet pages, synchronise your handheld, and possibly access the Internet. You can connect to a network in one of two ways:

- Create a modem connection by using a RAS account.

Before you can create this modem connection, your network administrator will need to set up a RAS account for you. If this is the method you want to use, see "To create a modem connection to a network" later on this page. Your network administrator may also give you VPN settings.

- Use an Ethernet card and a net tap to connect to the network.

If this is the method you want to use, see "To create an Ethernet connection to a network" on page 112.

You can use either an Ethernet PC Card or a CompactFlash Ethernet card. Either way, you will need to use an expansion sleeve (optional accessory) to make the connection.

9 Getting connected

Starting a connection

To create a modem connection to a network

- 1 Get the following information from your network administrator:
 - Dial-up access telephone number
 - User name and password
 - Domain name
 - TCP/IP settings
- 2 If your handheld does not have a built-in modem, install a modem card.
- 3 Tap  and then Settings. In the Connections tab, tap Connections. Under The Internet settings, select Internet Settings and tap Modify.
- 4 In the Modem tab, tap New.
- 5 Enter a name for the connection, such as "Company Connection".
- 6 Follow steps 8 to 12 on page 110.

To create an Ethernet connection to a network

You do not need to create a new connection on your handheld. Instead, you must purchase and configure an Ethernet card that is compatible with your handheld.

- 1 Follow steps 1 to 6 on page 111.
- 2 From the My network card connects to list, select Work.

Starting a connection

To start the connection, simply start using one of the following programs. Your handheld will automatically begin connecting. Once connected, you can:

- Send and receive email messages by using Inbox.
Before you can use Inbox, you need to provide the information it needs to communicate with the email server.
For instructions, see "Connecting directly to an email server" on page 113.
- Visit Web and WAP pages by using Pocket Internet Explorer.
For more information, refer to "10 Using Microsoft® Pocket Internet Explorer" on page 115.
- Send and receive instant messages with MSN Messenger.
For more information, refer to "MSN® Messenger" on page 55.

Ending a connection

To disconnect, do any of the following:

- When connected via cable or cradle, detach your handheld from the cable or cradle.
- When connected via Infrared, move your handheld away from the computer.

- When connected via dial-up or VPN, tap the Connection icon  on your navigation bar, and then tap End.
- When connected via a network (Ethernet) card, remove the card from your handheld.

Connecting directly to an email server

You can set up a connection to an email server so that you can send and receive email messages by using a modem or network connection and Inbox on your handheld.

NOTE: The ISP or network must use a POP3 or IMAP4 email server and an SMTP gateway.

You can use multiple email services to receive your messages. For each email service you intend to use, first set up and name the email service. If you use the same service to connect to different mailboxes, set up and name each mailbox connection.

To set up an email service

- 1 In Inbox on your handheld, tap Services.
- 2 Tap New Service.
- 3 Follow the directions in the New Service wizard.

For an explanation of a screen, tap  and then Help. When finished connecting to your email server, tap Services and then Connect.

For more information on using the Inbox program, see "Inbox" on page 43.

Getting help on connecting

More information on the procedures described here, as well as information on additional procedures, can be found in the following locations:

- The section on "Inbox" on page 43.
- Online Help of your handheld. Tap  and then Help. Tap View, All Installed Help, and then Inbox or Connections.
- ActiveSync Help on the your computer. In ActiveSync, click Microsoft ActiveSync Help on the Help menu.
- For troubleshooting information, see the Pocket PC Web site at (<http://www.microsoft.com/mobile/pocketpc/>).

9 Getting connected
Getting help on connecting

10 Using Microsoft® Pocket Internet Explorer

Use Microsoft® Pocket Internet Explorer to view Web or WAP pages in either of these ways:

- During synchronisation with your computer, download your favorite links and mobile favorites that are stored in the Mobile Favorites subfolder of Internet Explorer on your computer.
- Connect to an Internet service provider (ISP) or network and browse the Web. To do this, you'll need to create the connection first, as described in "9 Getting connected" on page 101.

When connected to an ISP or network, you can also download files and programs from the Internet or intranet.

Mobile Favorites folder

Only items stored in the Mobile Favorites subfolder in the Favorites folder of Internet Explorer on your computer will be synchronised with your handheld. This folder was created automatically when you installed ActiveSync.

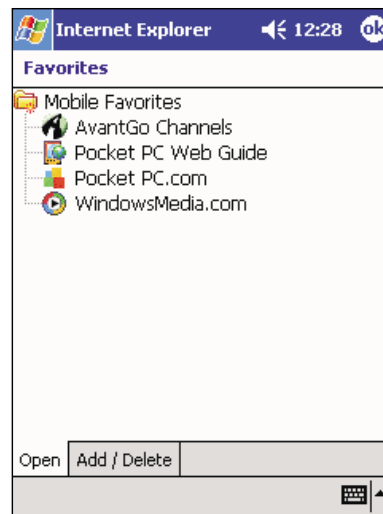

Favorite links

During synchronisation, the list of favorite links in the Mobile Favorites folder on your computer is synchronised with Pocket Internet Explorer on your handheld. Both locations are updated with changes made to either list each time you synchronise.

10 Using Microsoft® Pocket Internet Explorer

Mobile Favorites folder

Unless you mark the favorite link as a mobile favorite, only the link will be downloaded to your handheld, and you will need to connect to your ISP or network to view the content.

For more information on synchronisation, see ActiveSync Help on your computer.

Mobile favorites

If you are using Microsoft Internet Explorer 5.0 or later on your computer, you can download mobile favorites to your handheld. Synchronising mobile favorites downloads Web content to your handheld enable you to view pages while you are disconnected from your ISP and computer.

Use the Internet Explorer plug-in installed with ActiveSync to create mobile favorites quickly.

To create a mobile favorite

- 1 In Internet Explorer on your computer, click Tools and then Create Mobile Favorite.
- 2 To change the link name, enter a new name in the Name box.
- 3 Optionally, in Update, select a desired update schedule.

NOTE: If you did not specify an update schedule, you will need to manually download content to keep the information updated on both your computer and handheld. Before synchronising with your handheld, in Internet Explorer on your computer, click Tools and then Synchronise. You will see the last time content was downloaded to the computer, and you can manually download content if needed.

- 4 Click OK.

Internet Explorer downloads the latest version of the page to your computer.

TIP: You can add a button to the Internet Explorer toolbar for creating mobile favorites. In Internet Explorer on your computer, click View, Toolbars, and then Customise.

To download a mobile favorite

- 1 Right-click the mobile favorite and then click Properties.
- 2 In the Download tab, specify the number of links deep you want to download.
To conserve handheld memory, go only one level deep.
- 3 Synchronise your handheld and computer.

Mobile favorites that are stored in the Mobile Favorites folder in Internet Explorer are downloaded to your handheld.

To save handheld memory in downloading mobile favorites

Mobile favorites take up storage memory on your handheld. To minimise the amount of memory used, observe the following:

- In the settings for the Favorites information type in ActiveSync options, turn off pictures and sounds, or stop some mobile favorites from being downloaded to your handheld.

- Limit the number of downloaded linked pages.
 - a In Internet Explorer on the computer, right-click the mobile favorite you want to change and then click Properties.
 - b In the Download tab, specify 0 or 1 for the number of linked pages you want to download.

AvantGo channels

AvantGo is a free interactive service that gives you access to personalised content and thousands of popular Web sites. You subscribe to AvantGo channels directly from your handheld, then, you synchronise your handheld and computer, or connect to the Internet to download the content. For more information, visit the AvantGo Web site.

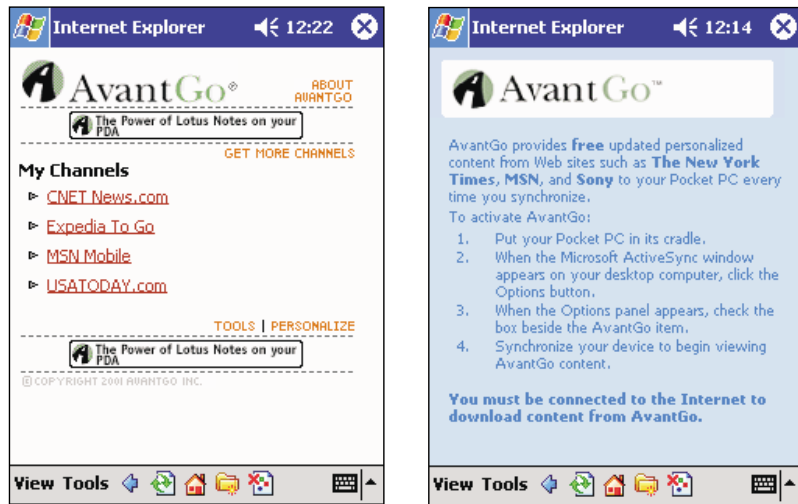

Signing up for AvantGo

- 1 In ActiveSync options on your computer, turn on synchronisation for the AvantGo information type.
- 2 In Pocket Internet Explorer on your handheld, tap the Favorites button to display your list of favorites.
- 3 Tap the AvantGo Channels link.
- 4 Tap the Activate button.
- 5 Follow the onscreen directions.
- 6 To complete the setup, synchronise your handheld with your computer and then tap the My Channels button.

When synchronisation is complete, tap the AvantGo Channels link in your list of favorites to see a few of the most popular channels.

10 Using Microsoft® Pocket Internet Explorer

Using Pocket Internet Explorer

To add or remove channels

- Tap the Add or Remove link.

Using Pocket Internet Explorer

You can use Pocket Internet Explorer to browse mobile favorites and channels that have been downloaded to your handheld without connecting to the Internet. You can also connect to the Internet through an ISP or a network connection and browse the Web.

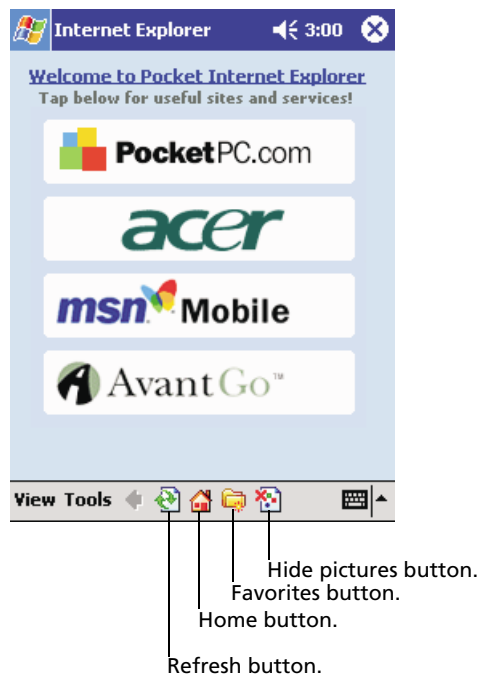

To view mobile favorites and channels

- 1 Tap the Favorites button to display your list of favorites.

10 Using Microsoft® Pocket Internet Explorer *Using Pocket Internet Explorer*

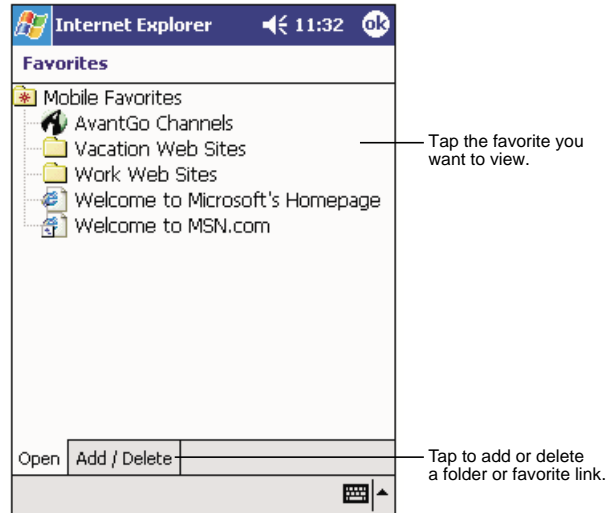

- 2 Tap the page you want to view.

You'll see the page that was downloaded the last time you synchronised with your computer. If the page is not on your handheld, the favorite will be dimmed. You will need to synchronise with your computer again to download the page to your handheld, or connect to the Internet to view the page.

To browse the Internet

- 1 Set up a connection to your ISP or corporate network, as described in "9 Getting connected" on page 101.
- 2 To connect and start browsing, do one of the following:
 - Tap the Favorites button, and then tap the favorite you want to view.
 - Tap View and then Address Bar. In the address bar that appears at the top of the screen, enter the Web address you want to visit and then tap Go. Tap the arrow to choose from previously entered addresses.
 - To add a favorite link while using the handheld:
 - a Go to the page you want to add.
 - b Tap and hold on the page.
 - c Tap Add to Favorites.

10 Using Microsoft® Pocket Internet Explorer

Using Pocket Internet Explorer

11 Customising your handheld

You can customise your handheld based on your personal requirements and preferences as well as depending on your usual work modes. Customise your handheld by doing either of the following:

- Adjust the handheld settings
- Add or remove programs

Adjusting handheld settings

You can adjust the settings of your handheld to suit the way you work.

To access Settings

- Tap , then Settings.

The Settings window has three tabs—Personal, System, and Connections, each of which has its own set of options.

The succeeding sections show the configuration page of each the Settings options. For detailed instructions on these pages, access the page from your handheld, tap , then Help.

11 Customising your handheld

Adjusting handheld settings

Personal

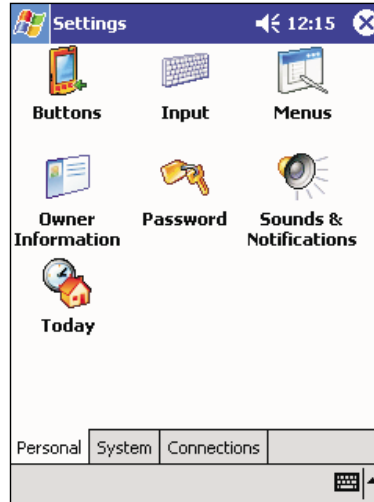

Buttons

Assign your favorite programs to any of the Quick buttons.

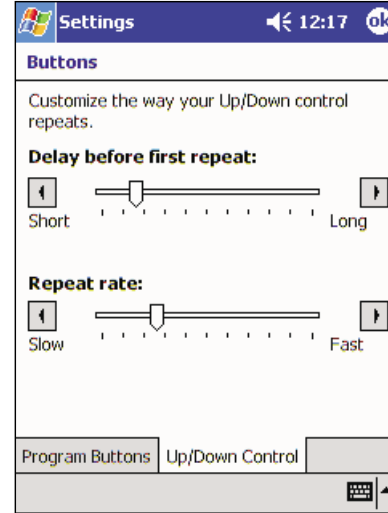
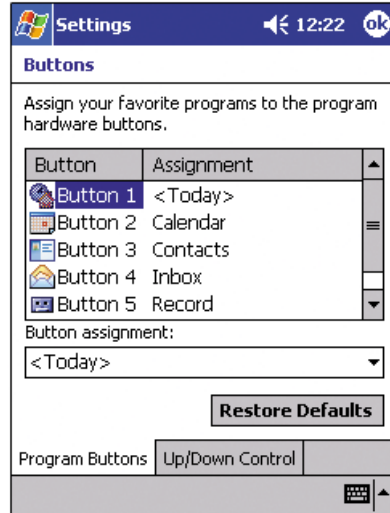

Input

Select an input method, options for word completion and other related settings.

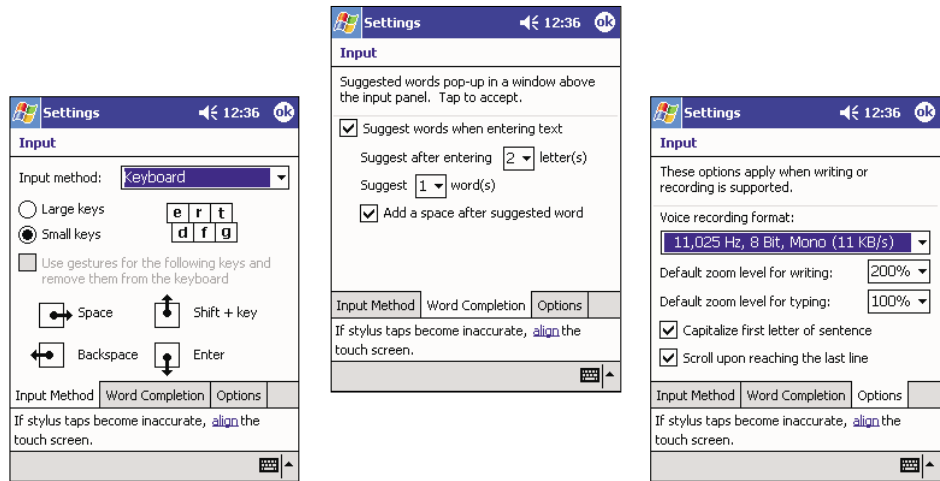

Menus

Customise what appears on the  menu, and enable a pop-up menu from the New button.

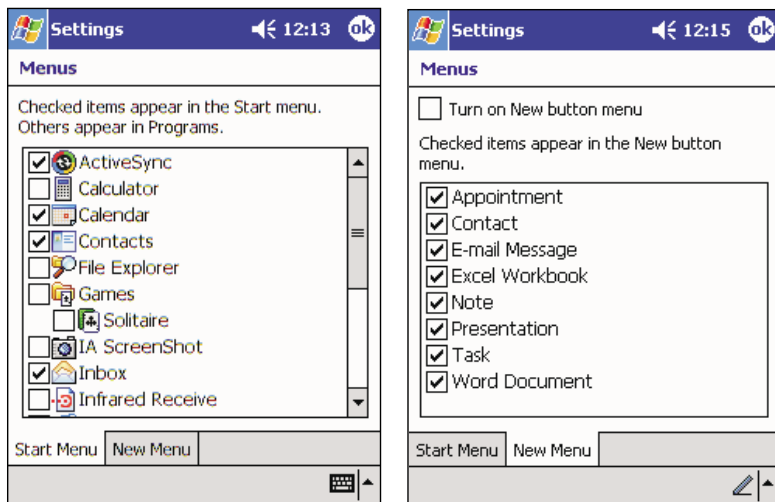

11 Customising your handheld

Adjusting handheld settings

Owner Information

Enter personal information and customise text display when handheld is turned on.

The first screenshot shows the 'Owner Information' screen with the following fields: Name, Company, Address, Telephone, and E-mail. Below these fields is a checkbox labeled 'Show information when device is turned on'. The second screenshot shows the same screen with the 'Notes' field expanded and the checkbox checked.

Password

Set a password to prevent unauthorized access to your handheld.

The first screenshot shows the 'Password' screen with three radio button options: 'No password', 'Simple 4 digit password', and 'Strong alphanumeric password'. Below these is a dropdown menu for 'Prompt if device unused for' set to '1 hour' and a 'Password' input field. The second screenshot shows a numeric keypad with buttons for digits 1-9, 0, CLR, and ENTR. The third screenshot shows the 'Confirm' field.

Sounds & Notification

Select the types of action you want to hear sounds for and define how you want to be notified about different events.

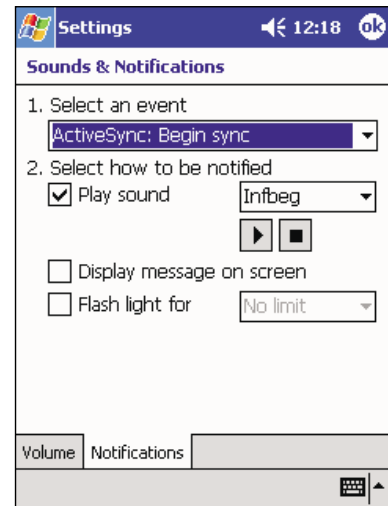
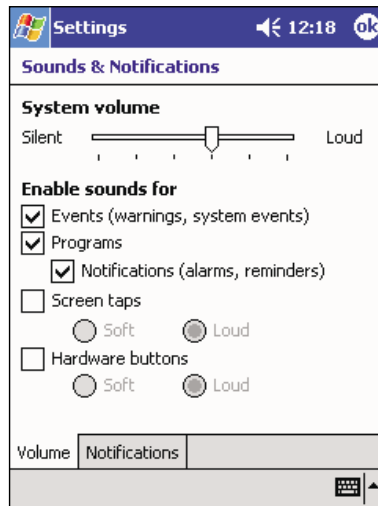

Today

Customise the look and the information that is displayed on the Today screen.

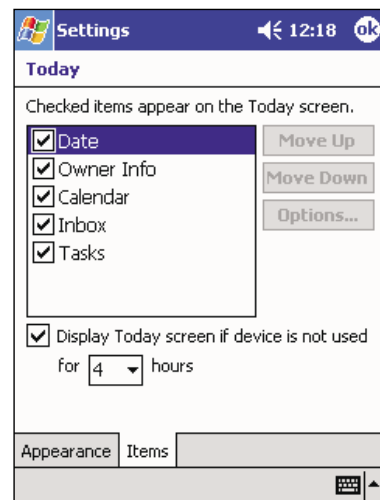
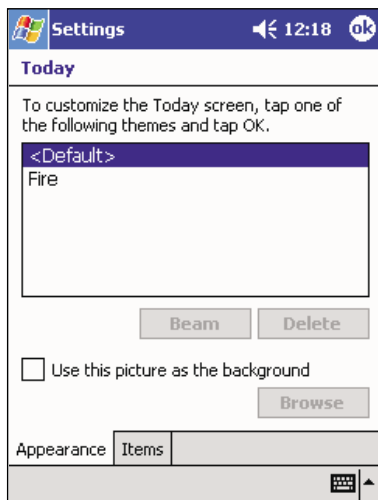

11 Customising your handheld

Adjusting handheld settings

System

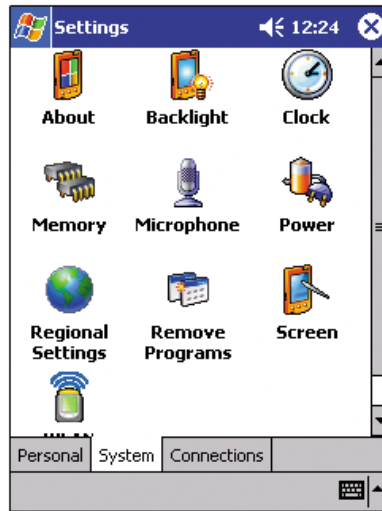

About

Displays your handheld's version and copyright information; includes an option to define a device ID.

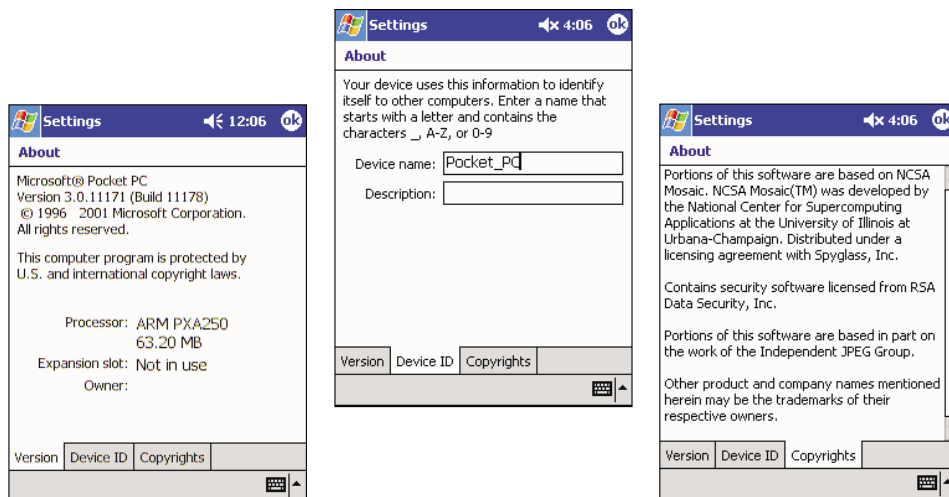

Backlight

Define settings for backlight control.

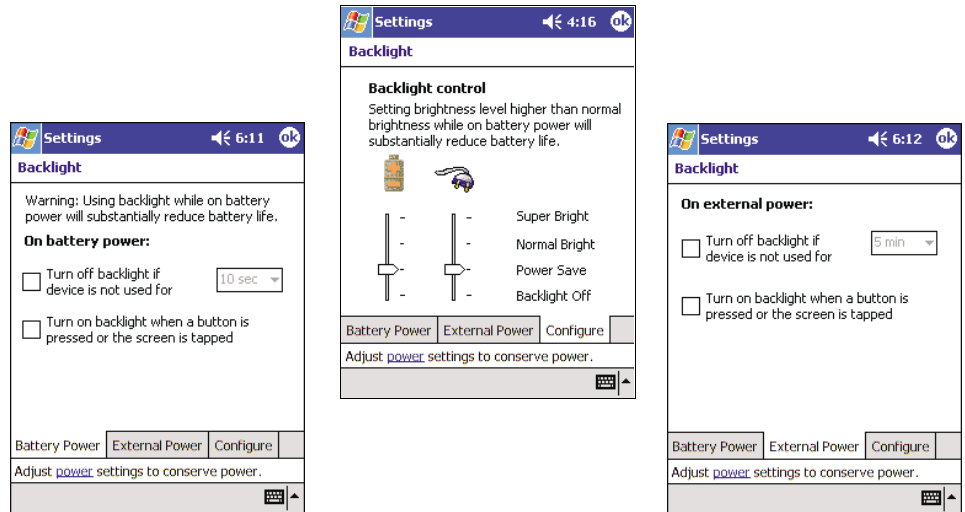

Clock

Change the time or set alarms.

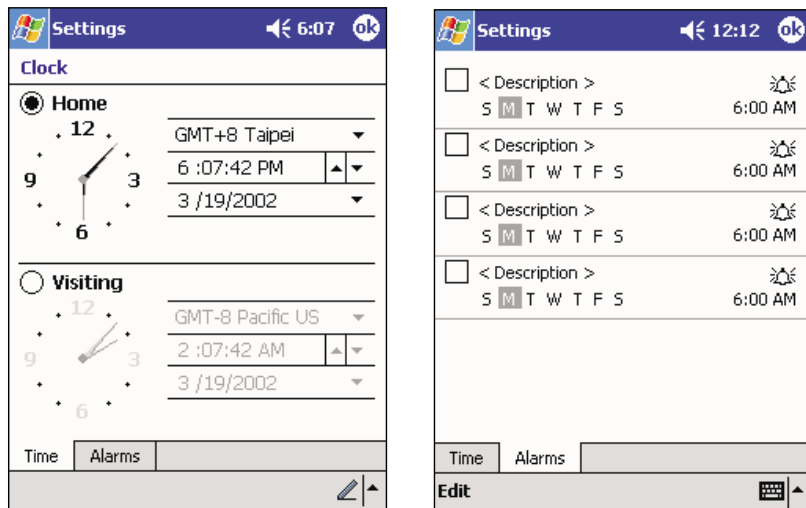

11 Customising your handheld

Adjusting handheld settings

Memory

Adjust allocation of storage and main memory.

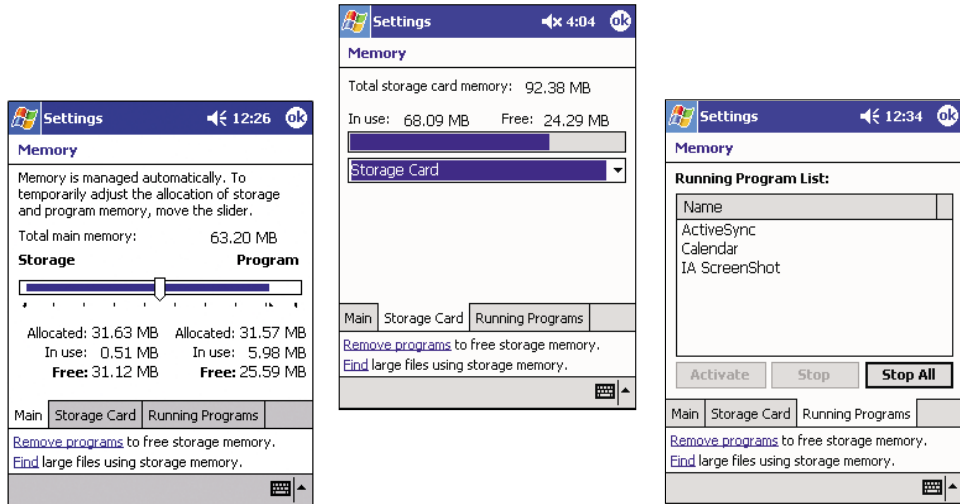

Microphone

Enable or disable the AGC (Automatic Gain Control) function—volume control when making an audio recording.

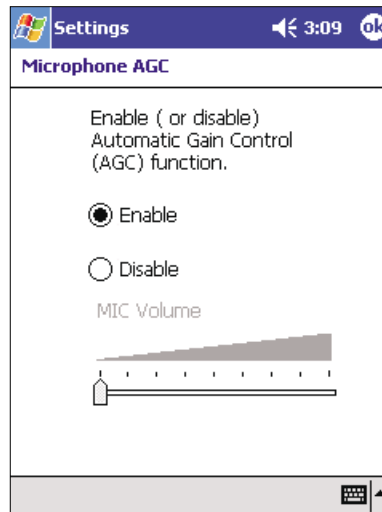

Power

Define settings to minimise power consumption.

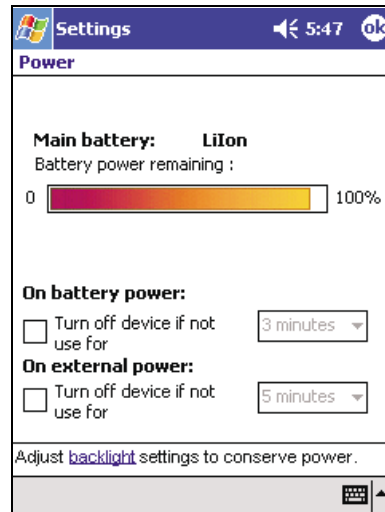

11 Customising your handheld

Adjusting handheld settings

Regional Settings

Set default number and time display formats and other related options.

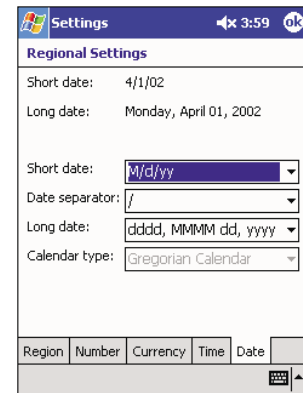
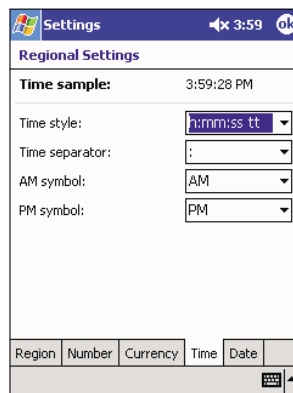
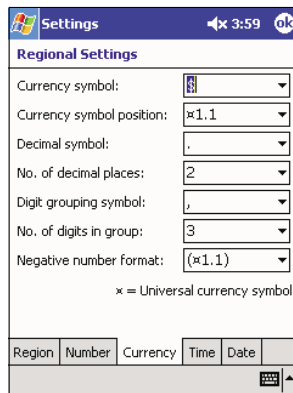
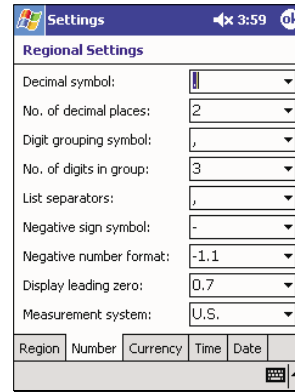
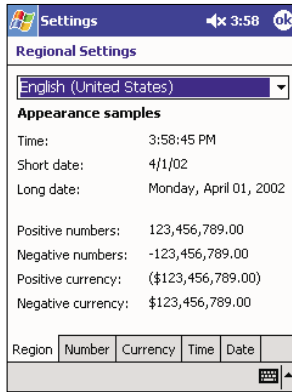

Remove Programs

Remove programs from storage memory.

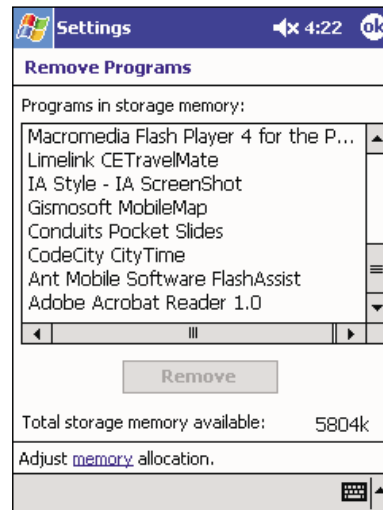

Screen

Align screen and enable the ClearType feature.

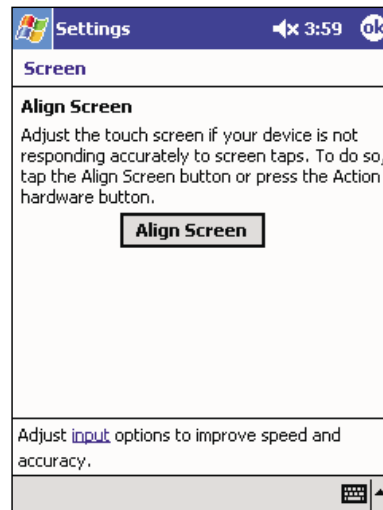

WLAN

Configure settings for your handheld's WLAN utility. For more information, refer to page 104.

11 Customising your handheld

Adjusting handheld settings

Connections

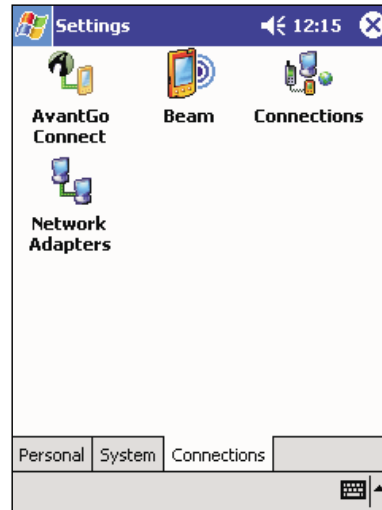

AvantGo Connect

Set server settings and related options for AvantGo.

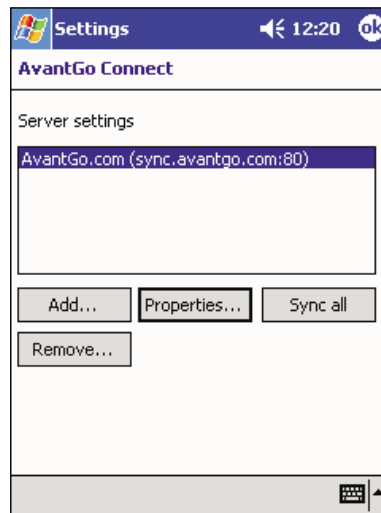

Beam

Define settings for the beam function.

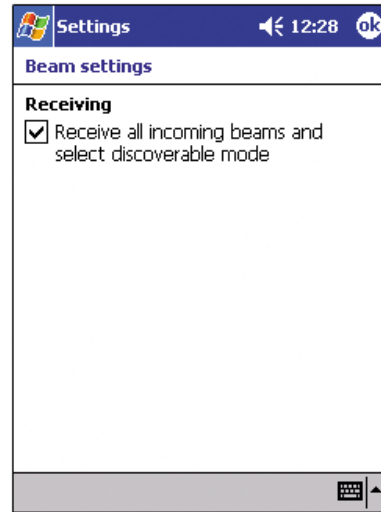

Connections

Adjust settings for connecting to the Internet or to a local network.

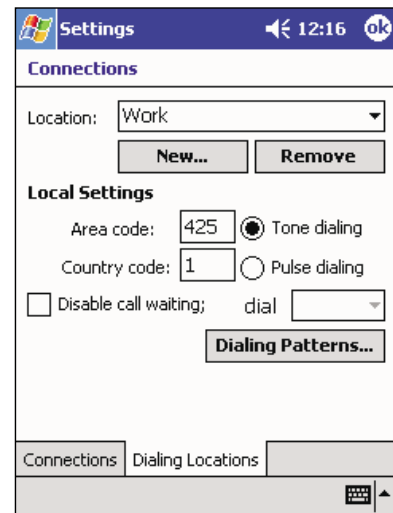
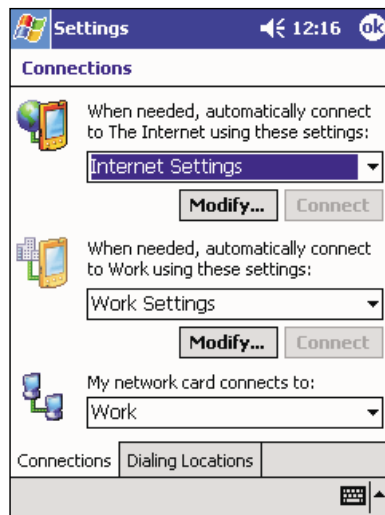

11 Customising your handheld

Adding and removing programs

Network Adapters

Select your handheld's network adapter and set its properties.

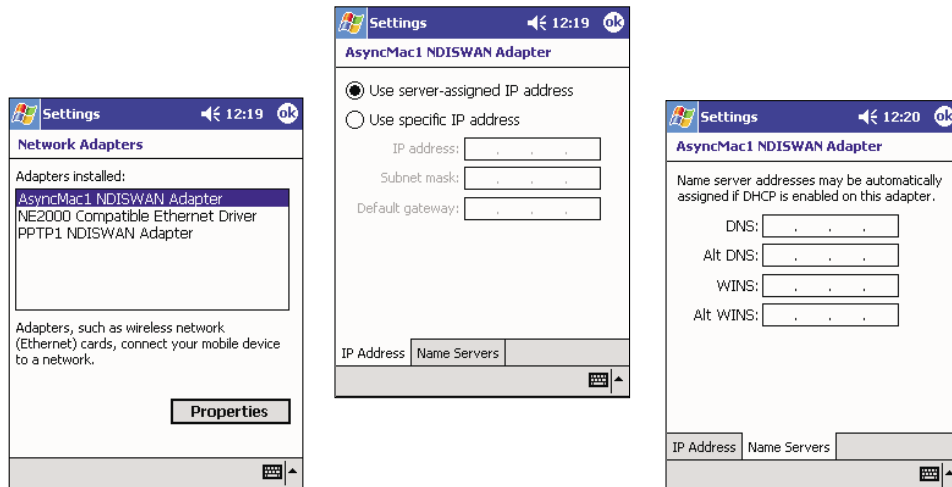

Adding and removing programs

Programs bundled with your handheld at the factory are stored in ROM (read-only memory). You cannot remove these programs, and you'll never accidentally lose ROM contents. ROM programs can be updated using special installation programs with a *.xip extension. All other programs and data files installed to your handheld after factory installation are stored in RAM (random access memory).

You can install any program created for your handheld, as long as it has enough memory. The most popular place to find software for your handheld is on the Pocket PC Web site (<http://www.microsoft.com/mobile/pocketpc/>).

Adding programs

You can add programs to your handheld either by using ActiveSync or by downloading the program from the Internet.

To add programs using ActiveSync

You'll need to install the appropriate software for your handheld on your computer before installing it on your handheld.

- 1 Determine your handheld and processor type so that you know which version of the software to install.
 - a Tap  and then Settings.
 - b On the System tab, tap About.
 - c In the Version tab, make a note of the information in Processor.

11 Customising your handheld

Adding and removing programs

- 2 Download the program to your computer (or insert the CD or disk that contains the program into your computer).

You may see a single *.xip, *.exe, or *.zip file, a Setup.exe file, or several versions of files for different device types and processors. Be sure to select the program designed for a Pocket PC and your handheld's processor type.

NOTE: Read any installation instructions, Read Me files, or documentation that come with the program. Many programs provide special installation instructions.

- 3 Connect your handheld to your computer.
- 4 Double-click the *.exe file.
 - If the file is an installer, the installation wizard will begin. Follow the directions on the screen. Once the software has been installed on your computer, the installer will automatically transfer the software to your handheld.
 - If the file is not an installer, you will see an error message stating that the program is valid but it is designed for a different type of computer. You will need to move this file to your handheld. If you cannot find any installation instructions for the program in the Read Me file or documentation, use ActiveSync Explore to copy the program file to the Program Files folder on your handheld. For more information on copying files using ActiveSync, see ActiveSync Help.
- 5 Once installation is complete, tap , Programs, and then the program icon to launch it.

To add a program directly from the Internet

- 1 Determine your handheld and processor type so that you know which version of the software to install.
 - a Tap  and then Settings.
 - b On the System tab, tap About.
 - c In the Version tab, make a note of the information in Processor.
- 2 Download the program to your handheld straight from the Internet using Pocket Internet Explorer.

You may see a single *.xip, *.exe or *.zip file, a Setup.exe file, or several versions of files for different device types and processors. Be sure to select the program designed for a Pocket PC and your handheld's processor type.

NOTE: Read any installation instructions, Read Me files, or documentation that comes with the program. Many programs provide special installation instructions.

- 3 Tap the file, such as a *.xip or *.exe file.

The installation wizard will begin.
- 4 Follow the directions on the screen.

11 Customising your handheld

Adding a program to the Start menu

Removing programs

- 1 Tap  and then Settings.
- 2 On the System tab, tap Remove Programs.





- 3 Tap the program you wish to remove.
- 4 Tap Remove.
If the program does not appear in the list of installed programs, use File Explorer on your handheld to locate the program:
 - 1 Tap and hold the program.
 - 2 Tap Delete on the pop-up menu.

Adding a program to the Start menu

- Tap , Settings, Menus, the Start Menu tab, and then the check box for the program.
If you do not see the program listed, you can either use File Explorer on your handheld to move the program to the Start Menu folder, or use ActiveSync on your computer to create a shortcut to the program and place the shortcut in the Start Menu folder.

To add a Start menu program using File Explorer on your handheld

- 1 Tap , Programs, File Explorer, and locate the program (tap the folder list, labeled My Documents by default, and then My Device to see a list of all folders on your handheld).
- 2 Tap and hold the program and tap Cut on the pop-up menu.
- 3 Open the Start Menu folder located in the Windows folder, tap and hold a blank area of the window.
- 4 Tap Paste on the pop-up menu.
- 5 The program will now appear on the  menu.
For more information on using File Explorer, see "To use File Explorer" on page 31.

To add a Start menu program using ActiveSync on your computer

- 1 Use the Explorer in ActiveSync to explore your handheld files and locate the program.
- 2 Right-click the program, and then click Create Shortcut.
- 3 Move the shortcut to the Start Menu folder in the Windows folder.
- 4 The shortcut now appears on the menu.
For more information on using ActiveSync, see ActiveSync Help on your computer.

11 Customising your handheld

Adding a program to the Start menu

Index

A

Acer Versatile Connector 93
Acrobat Reader for Pocket PC 85
ActiveSync 99
add program 134
AvantGo channels 117

B

backlight 4
Backup
 opening 65
 Restore function 70
Backup/Restore 64
Block Recognizer 20

C

Calendar 33
command interface 14
 command bar 17
 hardware buttons 14
 navigation bar 16
 notifications 18
 pop-up menus 17
 Today screen 15
 status icons 15
connectivity features 101
 connect to email server 113
 connect to Internet 110
 connect to network 111
 email service 113
 end connection 112
 help 113
 infrared
 receive 102
 wireless communication
 activating 103
 configuring 103
Contacts 36
copyright ii
customise features 121
 handheld settings 121
 install/remove program
 add 134
 using ActiveSync 134
 via Internet 135
 remove 136
customise handheld 121

E

email
 manage folders 47
 synchronise 44

email server 113
email service 113
enter data 19
 drawing on the screen 24
 recording a message 26
 using input panel 19
 Block Recognizer 20
 Letter Recognizer 20
 soft keyboard 20
 Transcriber 21
 using My Text 27
 writing on the screen 21
 convert to text 22
expansion features 91
 Acer Versatile Connector 93
 expansion sleeve 93
 attaching expansion sleeve 94
 inserting CompactFlash card 95
 inserting PC Card 96
 removing CompactFlash card 96
 removing PC Card 97
 Memory Stick 91
 inserting 91
 removing 92

H

handheld
 guides v
 maintenance vi
 optional accessories vi
 package contents vi
 resetting vii
handheld features 1
 audio 1
 battery pack 2
 install 8
 uninstall 9
 connectivity 1
 display 1
 ergonomics 2
 expansion 2
 performance 1
handheld setup
 charging 11
 LED status 12
 through the Acer Versatile Connector 12
 connecting cradle 10
 installing battery 12
 installing Microsoft ActiveSync software 7
 initial synchronisation 13

-
- I**
 - IA Album LE 75
 - menus 76
 - Inbox 43
 - input panel 19
 - Internet 110
 - L**
 - Letter Recognizer 20
 - M**
 - manage applications
 - application list 29
 - finding information 31
 - opening 29
 - organising information 31
 - switching 29
 - Memory Stick* 91
 - Microsoft Pocket Internet Explorer 115
 - AvantGo 117
 - signup 117
 - Mobile Favorites
 - create mobile favorite 116
 - favorite links 115
 - using 118
 - view mobile favorites 118
 - Microsoft Pocket Outlook 33
 - Calendar 33
 - create meeting request 36
 - open 33
 - schedule appointment 34
 - Contacts 36
 - create contact 37
 - find contact 38
 - open 36
 - Inbox 43
 - connect to email server 44
 - manage folders 47
 - Message list 45
 - open 43
 - synchronise email 44
 - Notes 42
 - create note 42
 - open 42
 - Tasks 39
 - open 39
 - Microsoft Pocket PC 2002 49
 - companion programs 49
 - Microsoft Reader
 - get book 59
 - read book 59
 - Reader features 60
 - remove book 61
 - use Guidebook 58
 - using Library 59
 - MSN Messenger 55, 57
 - chat with contacts 56
 - requirements 55
 - set up 56
 - work with contacts 56
 - Pocket Excel 53
 - File list 54
 - protect workbook 54
 - Pocket Word 49
 - enter data
 - drawing mode 52
 - recording mode 53
 - typing mode 50
 - writing mode 51
 - File list 50
 - Windows Media Player for Pocket PC 57
 - Microsoft Reader 58
 - Mobile Favorites folder 115
 - MSN Messenger 55
 - My Text 27
 - N**
 - Notes 42
 - P**
 - Pocket Excel 53
 - protect workbook 54
 - Pocket Word 49
 - PocketTV 86
 - R**
 - RecentDo 63
 - remove program 136
 - S**
 - system tour 3
 - bottom view 7
 - front view 3
 - left view 5
 - top view 6
 - T**
 - Tasks 39
 - third-party applications 63
 - Acrobat Reader for Pocket PC 85
 - Backup/Restore 64
 - IA Album LE 75
 - key features 76
 - Capture button 76
 - Crop and Save 76

menus 76
 File 76
 Tools 81
 screen capture preferences 82
 View 78
 select view 79
PocketTV 86
 Command bar 86
 Fullscreen/Landscape switch 86

Menu 88
 Options 89
 Seek bar 87
 Status bar 87
Transcriber 21

W

Windows Media Player for Pocket PC 57
