



EMC UPDATE TEST REPORT

For

LCD Monitor

Applicant : Compal Electronics Inc.
Trade Name : Compal; **acer
Model Number : CM870
Part Number : CM570; **CM670; **AM670; **AL722
Serial Number : N/A
Date : May 10, 2002
Date of test : May 9 ~ 10, 2002
Revision : 01
Reference Standard:

Standards	Results (Pass/Fail)
EN 55022: 1998	PASS
EN 61000-3-2: 1995 + A1: 1998 + A2: 1998 + A14: 2000	PASS
EN 61000-3-3: 1995 + A1: 2001	PASS
EN 55024: 1998 + A1: 2001	PASS
- IEC 61000-4-2: 1995 + A2: 2000	PASS
- IEC 61000-4-3: 1995	PASS
- IEC 61000-4-4: 1995	PASS
- IEC 61000-4-5: 1995	PASS
- IEC 61000-4-6: 1996	PASS
- IEC 61000-4-8: 1993	N/A
- IEC 61000-4-11: 1994	PASS

Description of Rev. 01:

1. Applicant adds one trade name for marketing purpose only.
(Please refer to have ** mark items on this report)
2. Applicant adds three part name on this report as per customer requested.
(Please refer to have ** mark items on this report)
3. Applicant adds two Panel to re-test.
(Please refer to have ** mark items on this report)
4. Other information please refers to the Rev.00 and this (Rev.01) test report.

Approved by Authorized Signatory:

Kurt Chen / Q.A. Manager



PRODUCT INFORMATION

Housing Type: Plastic

EUT Power Rating: DCV from Power Adapter

AC power during Test: 230VAC/50Hz to Power Adapter

Power Adapter Manufacturer: LI SHIN

Power Adapter Model Number: LSE9901B1260

Power Adapter Power Rating: I/P: 100-240VAC, 50/60Hz, 1.5A
O/P: 12VDC, 5A

AC Power Cord Type: Unshielded, 1.8m (Detachable) to Power Adapter

DC Power Cable Type: Unshielded, 1.8m (Non-detachable) at Power Adapter with a core

OSC/Clock Frequencies: 11.0592MHz/14.318MHz

17.4" LCD Panel Manufacturer: Fujitsu **Model:** FLC445XC8V
** AU L170E3-1-M170EN04
** HYUNDAI HT17E11

VGA Cable Type: Shielded, 1.8m with two cores (Detachable)

I/O Port of EUT:

I/O Port Type	Q'TY	Tested with
1). Video Port	1	1
2). Line in Port	1	1
3). Earphone Port	1	1



SUPPORT EQUIPMENT

No.	Equipment	Model #	Serial #	FCC ID	Trade Name	Data Cable	Power Cord
1.	PC	Presario 5180	1L8ABX422174	FCC DoC	Compaq	Audio Cable: Unshielded, 1.8m	Unshielded, 1.8m
2.	Modem	2400	94-364-176-277	DK467GSM24	Computer Peripherals	Shielded, 1.8m	Unshielded, 1.8m
3.	Printer	2225C	3050S82775	DSI6XU2225	HP	Shielded, 1.8m	Unshielded, 1.8m
4.	PS/2 Keyboard	SK-2800C	B1C790BCPJCN6L	GYUR79SK	Compaq	Shielded, 1.8m	N/A
5.	PS/2 Mouse	M-CAA43	LZA11750827	FCC DoC	Logitech	Shielded, 1.8m	N/A
6.	Earphone	GT-2004V	A5-1	N/A	GITON	Shielded, 1.8m	N/A

Note: All the above equipment/cables were placed in worse case positions to maximize emission signals during emission test.

Grounding: Grounding was in accordance with the manufacturer's requirements and conditions for the intended use.

BLOCK DIAGRAM OF TEST SETUP

System Diagram of Connections between EUT and Simulators

EUT: LCD Monitor

Trade Name: Compal

Model Number: CM870

AC Power Cord: Unshielded, 1.8m to Power Adapter

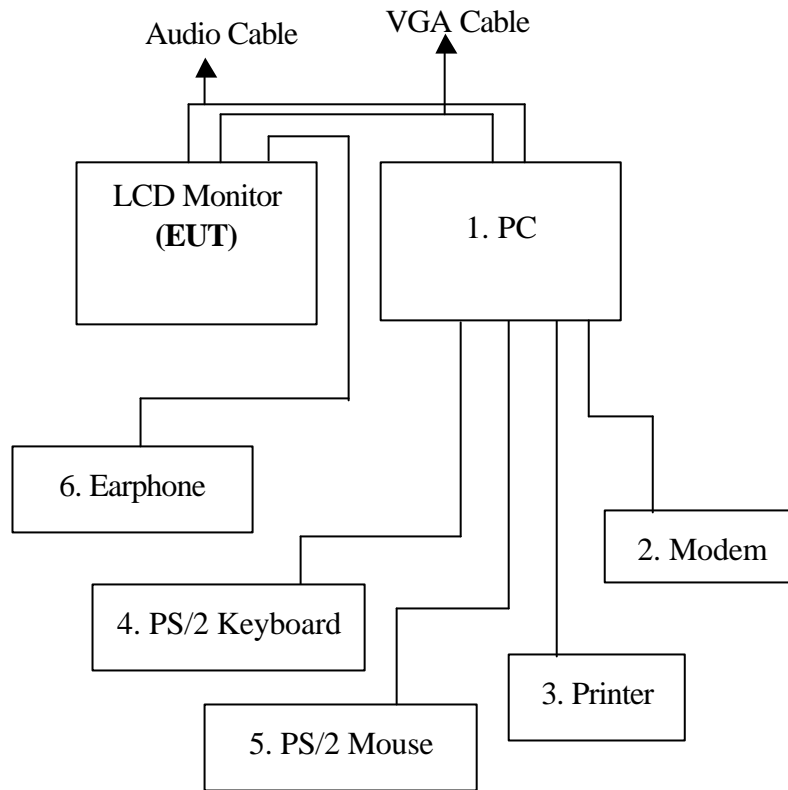



TEST EQUIPMENT LIST

Instrumentation: The following list contains equipment used at C & C Laboratory, Co., Ltd. for testing. The equipment conforms to the CISPR 16-1 / ANSI C63.2-1988 Specifications for Electromagnetic Interference and Field Strength Instrumentation from 10kHz to 1.0 / 2.0 GHz.

Equipment used during the tests:

Conducted Emission Test Site: #3

Conducted Emission Test Site # 3					
EQUIPMENT TYPE	MFR	MODEL NUMBER	SERIAL NUMBER	LAST CAL.	CAL DUE.
EMI Test Receiver	R&S	ESCS30	847793/012	12/19/2001	12/18/2002
LISN	R&S	ESH2-Z5	843285/010	12/10/2001	12/09/2002
LISN	EMCO	3825/2	9003-1628	07/16/2001	07/15/2002

Radiation Emission Test site:

Open Area Test Site: #1

Open Area Test Site # 1					
EQUIPMENT TYPE	MFR	MODEL NUMBER	SERIAL NUMBER	LAST CAL.	CAL DUE.
Q.P Adaptor	HP	85650A	2811A01399	06/19/2001	06/18/2002
RF Pre-selector	HP	85685A	2947A01064	06/19/2001	06/18/2002
Spectrum Analyzer	HP	8568B	3001A05004	06/19/2001	06/18/2002
S.P.A Display	HP	85662A	3014A18846	06/19/2001	06/18/2002
Precision Dipole	SCHWAZBECK	VHAP	998/999	05/17/2001	05/16/2002
Precision Dipole	SCHWAZBECK	UHAP	981/982	05/17/2001	05/16/2002
Bilog Antenna	CHASE	CBL6112A	2309	02/09/2002	02/08/2003
Turn Table	EMCO	2081-1.21	N/A	N.C.R	N.C.R
Antenna Tower	EMCO	2075-2	9707-2604	N.C.R	N.C.R
Controller	EMCO	2090	N/A	N.C.R	N.C.R
RF Switch	ANRITSU	MP59B	M54367	N.C.R	N.C.R
Site NSA	C&C	N/A	N/A	11/03/2001	11/02/2002
Spectrum Analyzer	ADVANTEST	R3261A	21720279	08/16/2001	08/15/2002



Power Harmonic & Voltage Fluctuation/Flicker Measurement (61000-3-2&-3-3)					
EQUIPMENT TYPE	MFR	MODEL NUMBER	SERIAL NUMBER	LAST CAL.	CAL DUE.
Harmonic & Flicker Tester	HAEFELY TRENCH	PHF555	080 419-25	10/12/2001	10/11/2002
ESD test (61000-4-2)					
EQUIPMENT TYPE	MFR	MODEL NUMBER	SERIAL NUMBER	LAST CAL.	CAL DUE.
ESD Generator	EMV	SESD 2000	812006	02/08/2002	02/07/2003
Radiated Electromagnetic Field immunity Measurement (61000-4-3)					
EQUIPMENT TYPE	MFR	MODEL NUMBER	SERIAL NUMBER	LAST CAL.	CAL DUE.
S.G.	R&S	SMY02	100094	08/03/2001	08/02/2002
Power Amplifier	ar	150W1000	300300	N/A	N/A
Power Antenna	EMCO	93141	9712-1083	N/A	N/A
EM PROBE	narda	EMR-20	AF-0024	06/28/2001	06/27/2002
Fast Transients/Burst test (61000-4-4)					
EQUIPMENT TYPE	MFR	MODEL NUMBER	SERIAL NUMBER	LAST CAL.	CAL DUE.
Fast Transients/Burst Generator	HAEFELY TRENCH	PEFT-JUNIOR	583 333-117	08/21/2001	08/20/2002
Surge Immunity test (61000-4-5)					
EQUIPMENT TYPE	MFR	MODEL NUMBER	SERIAL NUMBER	LAST CAL.	CAL DUE.
Surge Tester	HAEFELY TRENCH	PSUGER 4010	583 334-71	09/01/2001	08/31/2002
CS test (61000-4-6)					
EQUIPMENT TYPE	MFR	MODEL NUMBER	SERIAL NUMBER	LAST CAL.	CAL DUE.
S.G.	R&S	SMY02	100094	08/03/2001	08/02/2002
Power Amplifier	ar	500A100A	300299	N/A	N/A
CDN	MEB	M3	3683	09/14/2001	09/13/2002
CDN	Lüthi	801-M3	1879	03/05/2002	03/04/2003
CDN	MEB	M2	A3002010	04/24/2002	04/23/2003
Voltage Dips/Short Interruption and Voltage Variation Immunity test (61000-4-11)					
EQUIPMENT TYPE	MFR	MODEL NUMBER	SERIAL NUMBER	LAST CAL.	CAL DUE.
Dips/Interruption and Variations Simulator	HAEFELY TRENCH	PLINE 1610	080 344-05	04/08/2002	04/07/2003



EUT Configuration during measurement:

1) Pre-scan mode are list as below:

Mode(s): (Customer defined)

- 1. 1280 × 1024 Resolution (75Hz) + AU LCD Panel**
- 2. 1024 × 768 Resolution (75Hz) + AU LCD Panel**
- 3. 800 × 600 Resolution (75Hz) + AU LCD Panel**
- 4. 1280 × 1024 Resolution (75Hz) + HYUNDAI LCD Panel**

2) After pre-scan, found mode 1 producing the highest emission level, used this mode for all final test.



SUMMARY DATA (LINE CONDUCTED TEST)

Model Number: CM870

Location: Site # 3

Tested by: Tommy Lin

Test Mode: Mode 1

Test Results: Passed

Temperature: 25?

Humidity: 55? RH

(The chart below shows the highest readings taken from the final data)

FREQ MHz	Q.P. RAW dBuV	AVG RAW dBuV	Q.P. Limit dBuV	AVG Limit dBuV	Q.P. Margin dB	AVG Margin dB	NOTE
0.170	44.30	---	65.00	55.00	-20.7	---	L1
2.242	26.10	---	56.00	46.00	-29.9	---	L1
3.501	36.70	---	56.00	46.00	-19.3	---	L1
4.129	35.60	---	56.00	46.00	-20.4	---	L1
14.401	28.50	---	60.00	50.00	-31.5	---	L1
14.978	27.90	---	60.00	50.00	-32.1	---	L1
0.170	44.80	---	65.00	55.00	-20.2	---	L2
2.348	28.20	---	56.00	46.00	-27.8	---	L2
3.778	35.60	---	56.00	46.00	-20.4	---	L2
4.008	35.00	---	56.00	46.00	-21.0	---	L2
14.422	32.70	---	60.00	50.00	-27.3	---	L2
14.728	31.70	---	60.00	50.00	-28.3	---	L2

L1 = Line One (Hot side) / L2 = Line Two (Neutral side)

****NOTE:** “---” denotes the emission level complied with the Average limit, with at least 2dB margin,

so no further recheck.



SUMMARY DATA

(RADIATED EMISSION TEST)

Model Number: CM870

Location: Site # 1

Tested by: Tommy Lin

Polar: Vertical – 10m

Test Mode: Mode 1

Detector Function: Quasi-Peak

Test Results: Passed

Temperature: 28?

Humidity: 69? RH

(The chart below shows the highest readings taken from the final data)

Freq. (MHz)	Raw Data (dBuV/m)	Corr. Factor (dBuV)	Emiss. Level (dBuV/m)	Limits	Margin (dB)
33.06	8.3	18.9	27.2	30.0	-2.8
47.67	11.5	12.6	24.1	30.0	-5.9
135.25	14.0	12.2	26.2	30.0	-3.8
210.88	13.7	10.6	24.3	30.0	-5.7
629.27	10.9	23.0	33.9	37.0	-3.1
840.06	5.0	28.5	33.5	37.0	-3.5



SUMMARY DATA

(RADIATED EMISSION TEST)

Model Number: CM870

Location: Site # 1

Tested by: Tommy Lin

Polar: Horizontal – 10m

Test Mode: Mode 1

Detector Function: Quasi-Peak

Test Results: Passed

Temperature: 28?

Humidity: 69? RH

(The chart below shows the highest readings taken from the final data)

Freq. (MHz)	Raw Data (dBuV/m)	Corr. Factor (dBuV)	Emiss. Level (dBuV/m)	Limits	Margin (dB)
139.72	12.8	12.3	25.1	30.0	-4.9
210.27	12.5	10.6	23.1	30.0	-6.9
280.12	14.9	16.1	31.0	37.0	-6.0
349.52	15.2	17.7	32.9	37.0	-4.1
629.63	10.5	23.0	33.5	37.0	-3.5
768.20	8.3	26.2	34.5	37.0	-2.5

SECTION 1 EN 61000-3-2 & EN 61000-3-3 (POWER HARMONICS & VOLTAGE FLUCTUATION / FLICKER)

POWER HARMONICS MEASUREMENT

Port : AC mains
Basic Standard : EN 61000-3-2: 1995 + A1: 1998 + A2: 1998 + A14: 2000
Limits : CLASS A
Tester : Lung Tsai
Temperature : 23?
Humidity : 53?

VOLTAGE FLUCTUATION/FLICKER MEASUREMENT

Port : AC mains
Basic Standard : EN 61000-3-3: 1995
Limits : § 5 Section of EN 61000-3-3 : 1995 + A1 :2001
Tester : Lung Tsai
Temperature : 23?
Humidity : 53?

Block Diagram of Test Setup:

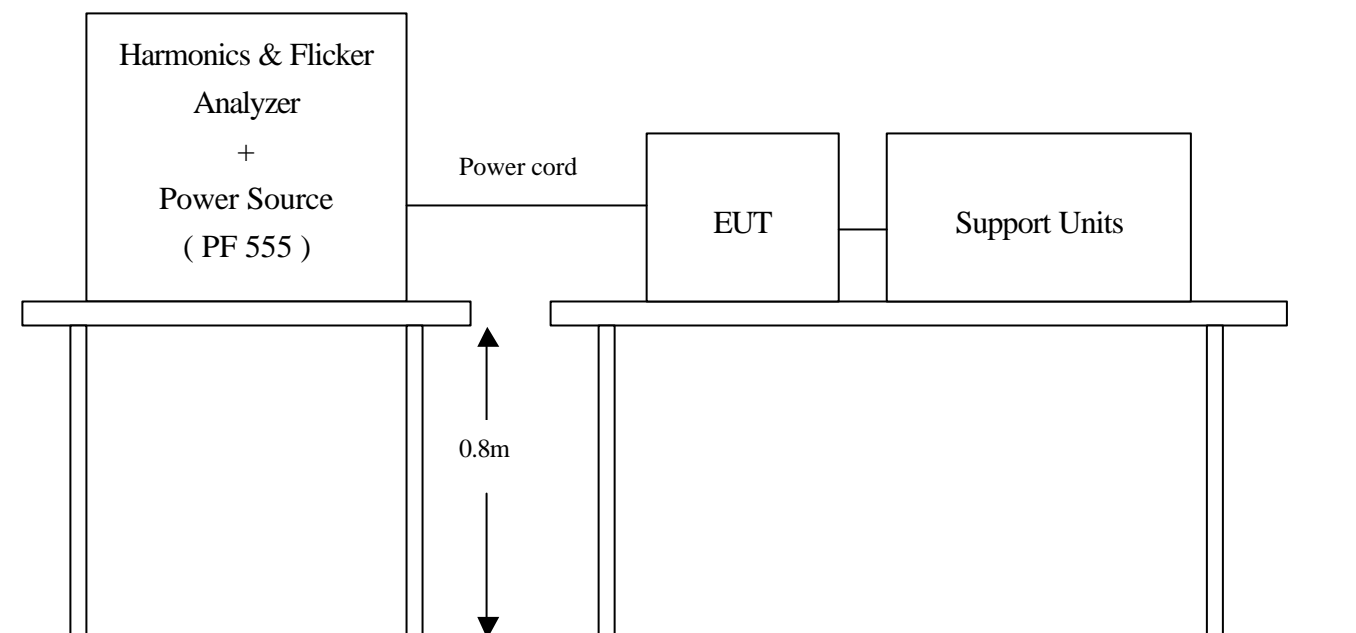

Result:

Please see the attached test data.



EN 61000-3-2 TEST REPORT 2002/5/9 09:52 PM

Unit: LCD MONITOR

Mdel No.: CMB70

Remarks: TEMP: 23? HUM 53%

Operator: LUNG TSAI

=====
TEST SETUP

Test Freq.:	50.00 Hz.	Test Voltage:	230.0 vac
Waveform :	SINE	Test Time:	2.5 mi n.
Classification :	CLASS A	Test Type:	STEADY-STATE

Prog. Zo Enabled:	YES	Prog. Zo:	0.000
-------------------	-----	-----------	-------

Mtor Driven with Phase Angle Control:	NO
Impedance selected:	DIRECT

Synthetic R+L Enabled:	NO
Resistance: 0.380 Ohms	Inductance: 460.000 uH

MAX WATTS: 36.0W



TEST DATA

Result: PASS

Harmonic Current Results

Hn	AMPS	LO Limit	HI Limit	Result
0	0.000	0.000	0.000	PASS
1	0.160	NaN	NaN	PASS
2	0.001	1.080	1.080	PASS
3	0.135	2.300	2.300	PASS
4	0.001	0.430	0.430	PASS
5	0.124	1.140	1.140	PASS
6	0.001	0.300	0.300	PASS
7	0.115	0.770	0.770	PASS
8	0.001	0.230	0.230	PASS
9	0.102	0.400	0.400	PASS
10	0.001	0.184	0.184	PASS
11	0.089	0.330	0.330	PASS
12	0.001	0.153	0.153	PASS
13	0.074	0.210	0.210	PASS
14	0.001	0.131	0.131	PASS
15	0.060	0.150	0.150	PASS
16	0.001	0.115	0.115	PASS
17	0.045	0.132	0.132	PASS
18	0.001	0.102	0.102	PASS
19	0.032	0.118	0.118	PASS
20	0.001	0.092	0.092	PASS
21	0.021	0.107	0.107	PASS



22	0.000	0.084	0.084	PASS
23	0.013	0.098	0.098	PASS
24	0.000	0.077	0.077	PASS
25	0.009	0.090	0.090	PASS
26	0.000	0.071	0.071	PASS
27	0.009	0.083	0.083	PASS
28	0.000	0.066	0.066	PASS
29	0.011	0.078	0.078	PASS
30	0.000	0.061	0.061	PASS
31	0.012	0.073	0.073	PASS
32	0.000	0.058	0.058	PASS
33	0.012	0.068	0.068	PASS
34	0.000	0.054	0.054	PASS
35	0.010	0.064	0.064	PASS
36	0.000	0.051	0.051	PASS
37	0.008	0.061	0.061	PASS
38	0.000	0.048	0.048	PASS
39	0.006	0.058	0.058	PASS
40	0.000	0.046	0.046	PASS

END OF REPORT



EN 61000-3-3 TEST REPORT 2002/5/9 10:09 PM

Unit: LCD MONITOR

Mdel No.: CMB70 (Continue)

Remarks: TEMP: 23? HUM 53%

Operator: LUNG TSAI

=====
TEST SETUP

Test Freq.: 50.00 Hz. Test Voltage: 230.0 vac
Waveform: SINE
Test Time: 10.0 min. Tshort: 10.0 min.

Prog. Zo Enabled: YES Prog. Zo: 0.000

Voltage Change less than once per Hour: NO
Impedance selected: DIRECT

Synthetic R+L Enabled: NO
Resistance: 0.380 Ohms Inductance: 460.000 uH



TEST DATA

Result: PASS

	EUT Data	Limit	Result	Test Enabled
Pst max	0.001	1.00	PASS	true
Plt max	0.001	0.65	PASS	true
dc %	0.00	3.00	PASS	true
dmax %	0.00	4.00	PASS	true
d(t) sec.	0.00	0.20	PASS	true

Power Source Data

Source Pst max	0.021	0.400	PASS	true
% THD	0.03	3.00	PASS	true

END OF REPORT



EN 61000-3-3 TEST REPORT 2002/5/9 10:23 PM

Unit: LCD MONITOR

Mdel No.: CMB70 (Manual Switch)

Remarks: TEMP: 23? HUM 53%

Operator: LUNG TSAI

=====
TEST SETUP

Test Freq.: 50.00 Hz. Test Voltage: 230.0 vac

Waveform: SINE

Test Time: 10.0 min. Tshort: 10.0 min.

Prog. Zo Enabled: YES Prog. Zo: 0.000

Voltage Change less than once per Hour: NO

Impedance selected: DIRECT

Synthetic R+L Enabled: NO

Resistance: 0.380 Ohms Inductance: 460.000 uH



TEST DATA

Result: PASS

	EUT Data	Limit	Result	Test Enabled
Pst max	0.001	1.00	PASS	true
Plt max	0.001	0.65	PASS	true
dc %	0.00	3.00	PASS	true
dmax %	0.00	4.00	PASS	true
d(t) sec.	0.00	0.20	PASS	true

Power Source Data

Source Pst max	0.021	0.400	PASS	true
% THD	0.03	3.00	PASS	true

END OF REPORT

SECTION 2 -- IMMUNITY TESTS (EN 55024:1998)

Electrostatic discharge (ESD) immunity test (IEC 61000-4-2)

Radiated electromagnetic field (RS) immunity test (IEC 61000-4-3)

Fast transient / Burst (EFT) immunity test (IEC 61000-4-4)

Surge immunity test (IEC 61000-4-5)

Conducted disturbances inducted by radio-frequency fields, (CS) immunity test (IEC 61000-4-6)

Power-frequency magnetic field immunity test (IEC 61000-4-8)

Voltage dips, short interruption and voltage variation immunity test (IEC 61000-4-11)

1. IEC 61000-4-2 (ELECTROSTATIC DISCHARGE)

ELECTROSTATIC DISCHARGE (ESD) IMMUNITY TEST

Port : Enclosure
Basic Standard : IEC 61000-4-2
Test Level : ± 8 kV (Air Discharge)
 : ± 4 kV (Contact Discharge)
 : ± 4 kV (Indirect Discharge)
Performance Criteria : B (Standard require)
Tester : Lung Tsai
Temperature/Humidity : 23? /53?

Block Diagram of Test Setup:

(The 470 k ohm resistors are installed per standard requirement)

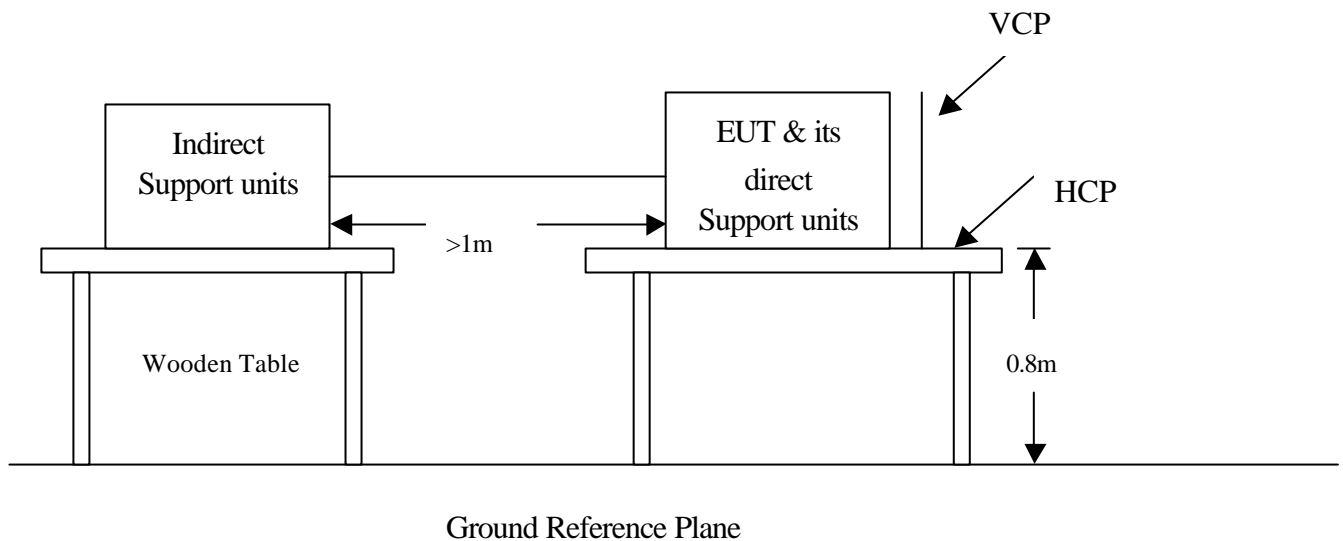



Test Procedure:

1. The EUT was located 0.1 m minimum from all side of the HCP.
2. The indirect support units were located 1 m minimum away from the EUT, but direct support unit was/were located at same location as EUT on the HCP and keep at a distance of 10 cm with EUT.
3. A scroll 'H' test program was loaded and executed in Windows mode.
4. The EUT sent above message to EUT and related peripherals through the test.
5. Active the communication function if the EUT with such port(s).
6. As per the requirement of EN 55024; applying direct contact discharge at the sides other than front of EUT at minimum 50 discharges (25 positive and 25 negative) if applicable, can't be applied direct contact discharge side of EUT then the indirect discharge shall be applied. One of the test points shall be subjected to at least 50 indirect discharge (contact) to the front edge of horizontal coupling plane.
7. Other parts of EUT where it is not possible to perform contact discharge then selecting appropriate points of EUT for air discharge, a minimum of 10 single air discharges shall be applied.
8. The application of ESD to the contact of open connectors is not required.
9. The EUT direct connection units also need to be applied ESD at the port of EUT cable connected.
10. Putting a mark on EUT to show tested points. The following test condition was followed during the tests.

Note: As per the IEC 61000-4-2:2001, with two 470k bleed resistors cable is connected between the EUT and HCP during the test applicable for power ungrounded or battery operating unit only.

The electrostatic discharges were applied as follows:

Amount of Discharges	Voltage	Coupling	Result (Pass/Fail)
Mini 25 /Point	±4kV	Contact Discharge	Pass
Mini 25 /Point	±4kV	Indirect Discharge HCP (Front)	Pass
Mini 25 /Point	±4kV	Indirect Discharge VCP (Left)	Pass
Mini 25 /Point	±4kV	Indirect Discharge VCP (Right)	Pass
Mini 25 /Point	±4kV	Indirect Discharge VCP (Back)	N/A
Mini 10 /Point	±8kV	Air Discharge	Pass

**** The tested points to EUT, please refer to attached page.**

(Blue arrow mark for Contact Discharge and red arrow mark for Air Discharge)

Performance & Result:

- Criteria A:** The apparatus continues to operate as intended. No degradation of performance or loss of function is allowed below a performance level specified by the manufacturer, when the apparatus is used as intended. In some cases the performance level may be replaced by a permissible loss of performance.
- Criteria B:** The apparatus continues to operate as intended after the test. No degradation of performance or loss of function is allowed below a performance level specified by the manufacturer, when the apparatus is used as intended. In some cases the performance level may be replaced by a permissible loss of performance. During the test, degradation of performance is however allowed.
- Criteria C:** Temporary loss of function is allowed, provided the functions self recoverable or can be restored by the operation of controls.

<input checked="" type="checkbox"/> PASS <input type="checkbox"/> FAILED
Observation: No any function degraded during the tests.

The Tested Points of EUT

(Photo 1 of 3)



(Photo 2 of 3)

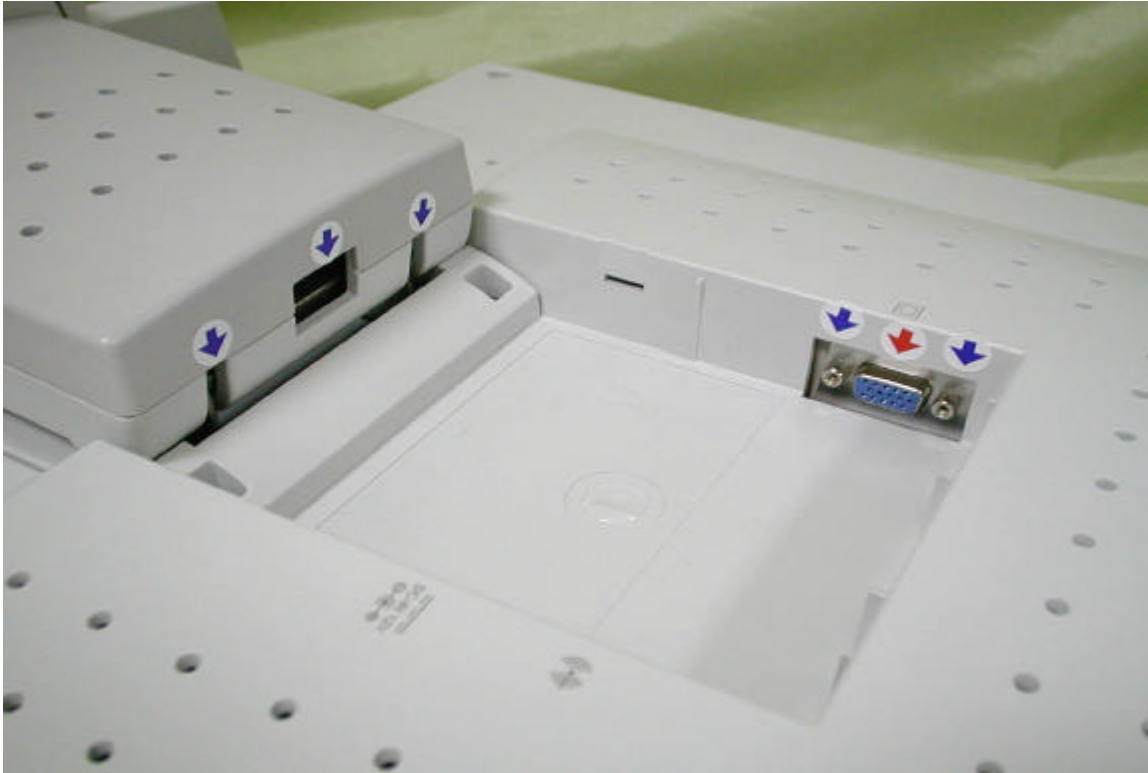

(Photo 3 of 3)



2. IEC 61000-4-3 (RADIATED ELECTROMAGNETIC FIELD)

RADIATED ELECTROMAGNETIC FIELD IMMUNITY TEST

Port : Enclosure
Basic Standard : IEC 61000-4-3
Requirements : 3 V/m / with 80% AM. 1kHz Modulation.
Performance Criteria : A (Standard require)
Tester : Tommy Lin
Temperature : 23?
Humidity : 53?

Block Diagram of Test Setup:

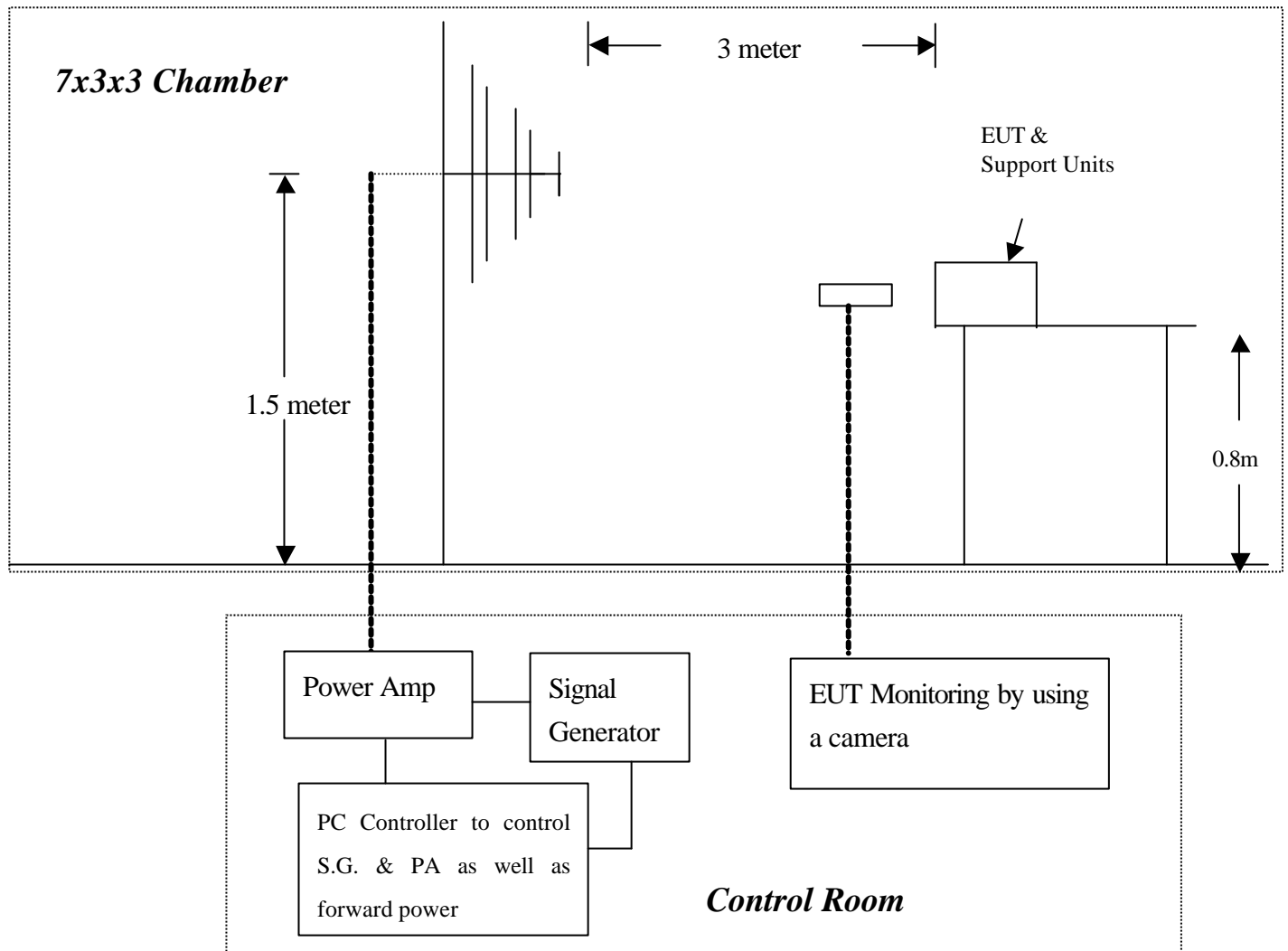



Test Procedure:

1. The EUT was located at the edge of supporting table keep 3 meter away from transmitting antenna, it just the calibrated square area of field uniformity. The support units were located outside of the uniformity area, but the cable(s) connected with EUT were exposed to the calibrated field as per IEC 61000-4-3.
2. A scroll ‘H’ messages were displayed on part of screen of EUT and an enlarged ‘H’ characters were displayed on the other part of screen of EUT.
3. Adjusting the monitoring camera to monitor the ‘H’ message as clear as possible.
4. Setting the testing parameters of RS test software per IEC 61000-4-3.
5. Performing the pre-test at each side of with double specified level (6V/m) at 4% steps.
6. From the result of pre-test in step 5, choice the worst side of EUT for final test from 80 MHz to 1000 MHz at 1% steps.
7. Recording the test result in following table.
8. It is not necessary to perform test as per annex A of EN 55024:1998 if the EUT doesn’t belong to TTE product.

IEC 61000-4-3 Preliminary test conditions:

Test level : 6V/m
Steps : 4 % of fundamental;
Dwell Time : 3 sec

Range (MHz)	Field	Modulation	Polarity	Position (°)	Result (Pass/Fail)
80-1000	6V	Yes	H	Front	Pass
80-1000	6V	Yes	V	Front	Pass
80-1000	6V	Yes	H	Right	Pass
80-1000	6V	Yes	V	Right	Pass
80-1000	6V	Yes	H	Back	Pass
80-1000	6V	Yes	V	Back	Pass
80-1000	6V	Yes	H	Left	Pass
80-1000	6V	Yes	V	Left	Pass

IEC 61000-4-3 Final test conditions:

Test level : 3V/m
Steps : 1 % of fundamental;
Dwell Time : 3 sec

Range (MHz)	Field	Modulation	Polarity	Position (°)	Result (Pass/Fail)
80-1000	3V	Yes	H	Front	Pass
80-1000	3V	Yes	V	Front	Pass



Performance & Result:

- Criteria A:** The apparatus continues to operate as intended. No degradation of performance or loss of function is allowed below a performance level specified by the manufacturer, when the apparatus is used as intended. In some cases the performance level may be replaced by a permissible loss of performance.

- Criteria B:** The apparatus continues to operate as intended after the test. No degradation of performance or loss of function is allowed below a performance level specified by the manufacturer, when the apparatus is used as intended. In some cases the performance level may be replaced by a permissible loss of performance. During the test, degradation of performance is however allowed.

- Criteria C:** Temporary loss of function is allowed, provided the functions self-recoverable or can be restored by the operation of controls.

<input checked="" type="checkbox"/> PASS <input type="checkbox"/> FAILED
Observation: No any function degraded during the tests.

3. IEC 61000-4-4 (FAST TRANSIENTS/BURST)

FAST TRANSIENTS/BURST IMMUNITY TEST

Port	: On Power Supply Lines
Basic Standard	: IEC 61000-4-4
Requirements	: +/- 1kV for Power Supply Lines
Performance Criteria	: B (Standard require)
Tester	: Lung Tsai
Temperature	: 23?
Humidity	: 53?

Block Diagram of Test Setup:

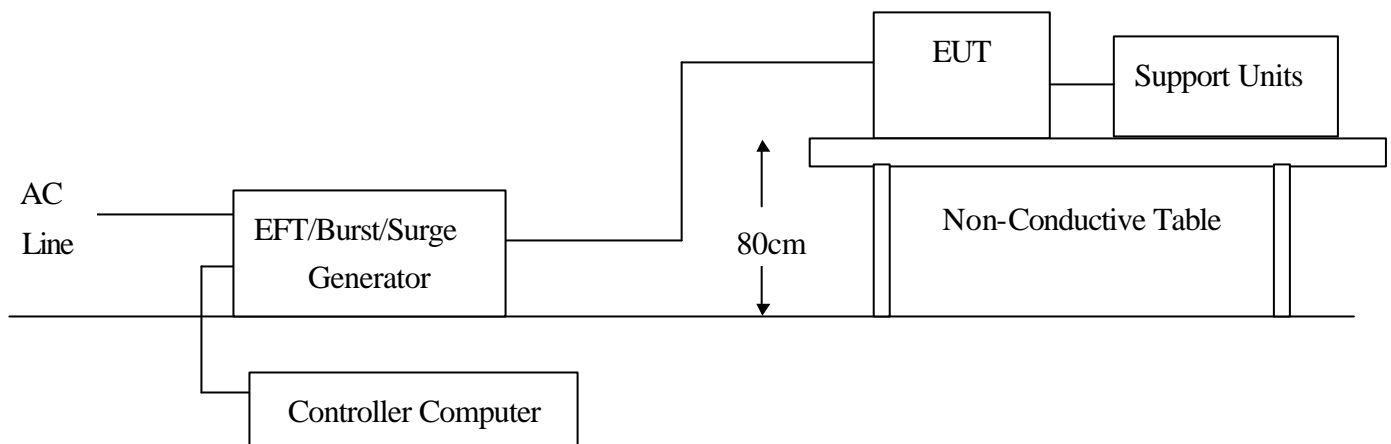



Test Procedure:

1. The EUT and support units were located on a wooden table 0.8 m away from ground reference plane.
2. A 1.0 meter long power cord was attached to EUT during the test.
3. The length of communication cable between communication port and clamp was keeping within 1 meter.
4. A test program was loaded and executed in Windows mode.
5. The data was sent to EUT filling the screens with upper case of “H” patterns.
6. The test program exercised related support units sequentially.
7. Repeating step 3 to 6 through the test and increase test voltage to the EUT ports from minimum to standard request or client request.
8. Recording the test result as shown in following table.

Test conditions:

Impulse Frequency: 5kHz
Tr/Th: 5/50ns
Burst Duration: 15ms
Burst Period: 3Hz

Inject Line	Voltage kV	Inject Method	Result (Pass/Fail)
L1	+/- 1	Direct	Pass
N	+/- 1	Direct	Pass
PE	+/- 1	Direct	Pass
L1+N	+/- 1	Direct	Pass
L1+PE	+/- 1	Direct	Pass
N+PE	+/- 1	Direct	Pass
L1 + N + PE	+/- 1	Direct	Pass

Performance & Result:

- Criteria A:** The apparatus continues to operate as intended. No degradation of performance or loss of function is allowed below a performance level specified by the manufacturer, when the apparatus is used as intended. In some cases the performance level may be replaced by a permissible loss of performance.
- Criteria B:** The apparatus continues to operate as intended after the test. No degradation of performance or loss of function is allowed below a performance level specified by the manufacturer, when the apparatus is used as intended. In some cases the performance level may be replaced by a permissible loss of performance. During the test, degradation of performance is however allowed.
- Criteria C:** Temporary loss of function is allowed, provided the functions self recoverable or can be restored by the operation of controls.

<input checked="" type="checkbox"/> PASS <input type="checkbox"/> FAILED
Observation: No any function degraded during the tests.

4. IEC 61000-4-5 (SURGE IMMUNITY)

SURGE IMMUNITY TEST

Port	: Power Cord
Basic Standard	: IEC 61000-4-5
Requirements	: +/- 1kV (Line to Line) : +/- 2kV (Line to Ground)
Performance Criteria	: B (Standard require)
Tester	: Lung Tsai
Temperature	: 23?
Humidity	: 53?

Block Diagram of Test Setup:

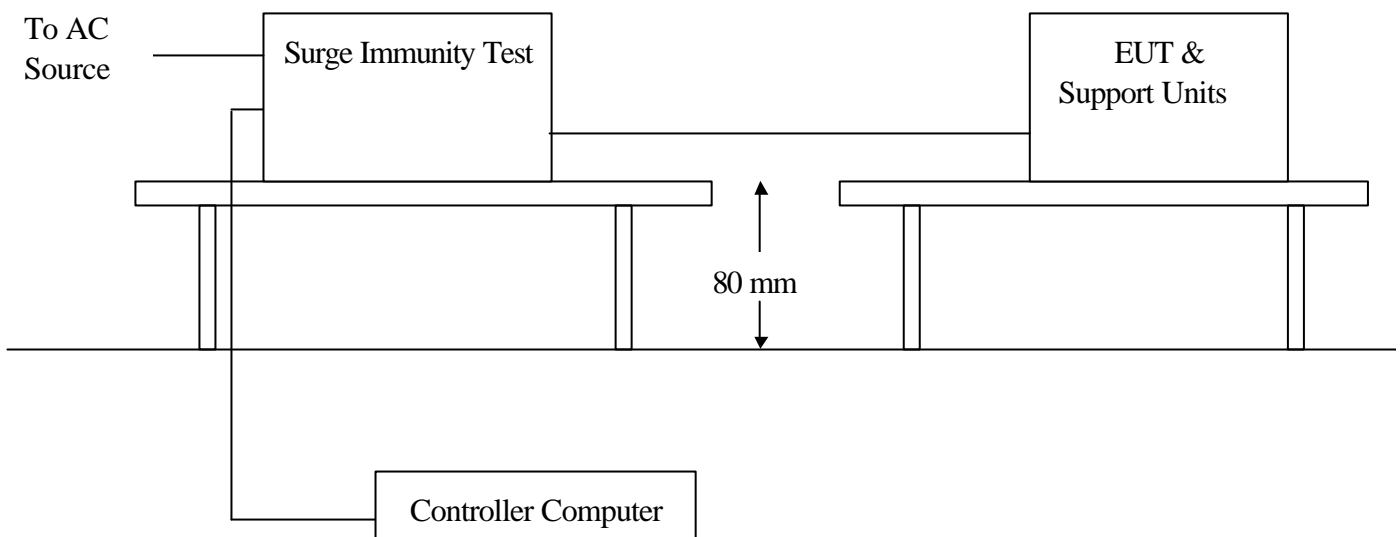



Test Procedure:

1. The EUT and support units were located on a wooden table 0.8 m away from ground floor.
2. A test program was loaded and executed in Windows mode.
3. The data was sent to EUT filling the screens with upper case of “H” patterns.
4. The test program exercised related support units sequentially.
5. Repeating step 3 to 4 through the test and increase test voltage to the EUT ports fro minimum to standard request or client request.
6. Recording the test result as shown in following table.

Test conditions:

Voltage Waveform : 1.2/50 us
Current Waveform : 8/20 us
Polarity : Positive/Negative
Phase angle : 0°, 90°, 270°
Number of Test : 5

Coupling Line	Voltage (kV)	Polarity	Coupling Method	Result (Pass/Fail)
L1-L2	1	Positive	Capacitive	Pass
L1-PE	2	Positive	Capacitive	Pass
L2-PE	2	Positive	Capacitive	Pass
L1-L2	1	Negative	Capacitive	Pass
L1-PE	2	Negative	Capacitive	Pass
L2-PE	2	Negative	Capacitive	Pass

Performance & Result:

- Criteria A:** The apparatus continues to operate as intended. No degradation of performance or loss of function is allowed below a performance level specified by the manufacturer, when the apparatus is used as intended. In some cases the performance level may be replaced by a permissible loss of performance.
- Criteria B:** The apparatus continues to operate as intended after the test. No degradation of performance or loss of function is allowed below a performance level specified by the manufacturer, when the apparatus is used as intended. In some cases the performance level may be replaced by a permissible loss of performance. During the test, degradation of performance is however allowed.
- Criteria C:** Temporary loss of function is allowed, provided the functions self recoverable or can be restored by the operation of controls.

<input checked="" type="checkbox"/> PASS <input type="checkbox"/> FAILED
Observation: No any function degraded during the tests.

5. IEC 61000-4-6 (CONDUCTED DISTURBANCE/INDUCED BY RADIO-FREQUENCY FIELD)

Port : AC Port
Basic Standard : IEC 61000-4-6
Requirements : 3V with modulated
Injection Method : CDN-M3
Performance Criteria : A (Standard require)
Tester : Lung Tsai
Temperature : 23?
Humidity : 53?

Block Diagram of Test Setup:

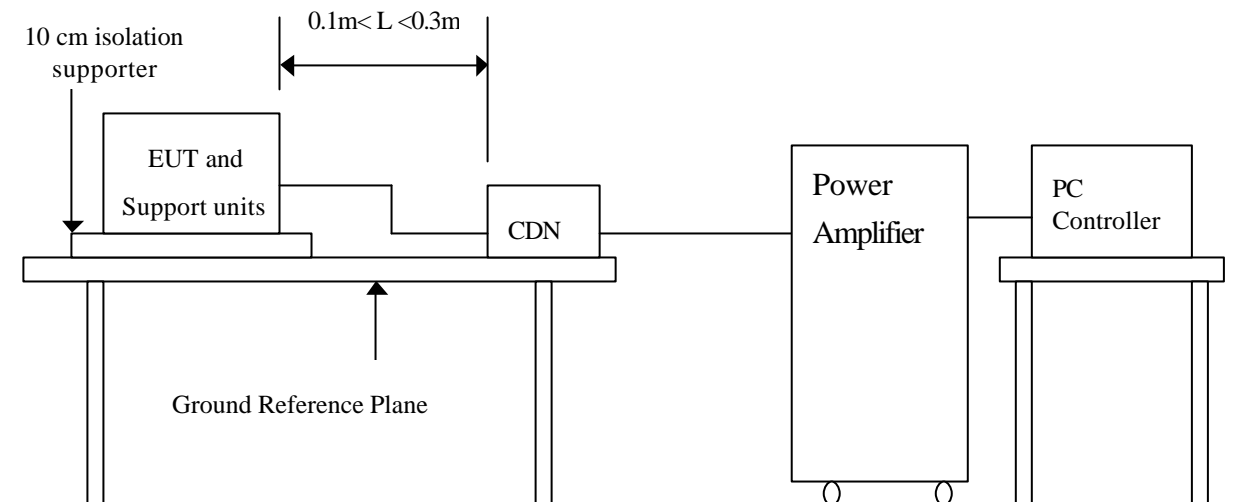



Test Procedure:

1. The EUT and support units were located at a ground reference plane with the interposition of a 0.1 m thickness insulating support and the CDN was located on GRP directly.
2. A 'H' messages were displayed on screen of EUT.
3. Adjusting the monitoring camera to monitor the 'H' message as clear as possible.
4. Setting the testing parameters of CS test software per IEC 61000-4-6.
5. Recording the test result in following table.

Test conditions:

Frequency Range : 0.15MHz-80MHz
Frequency Step : 1% of fundamental
Dwell Time : 3 sec

Range (MHz)	Field	Modulation	Result (Pass/Fail)
0.15-80	3V	Yes	Pass

Performance & Result:

- Criteria A:** The apparatus continues to operate as intended. No degradation of performance or loss of function is allowed below a performance level specified by the manufacturer, when the apparatus is used as intended. In some cases the performance level may be replaced by a permissible loss of performance.
- Criteria B:** The apparatus continues to operate as intended after the test. No degradation of performance or loss of function is allowed below a performance level specified by the manufacturer, when the apparatus is used as intended. In some cases the performance level may be replaced by a permissible loss of performance. During the test, degradation of performance is however allowed.
- Criteria C:** Temporary loss of function is allowed, provided the functions self-recoverable or can be restored by the operation of controls.

<input checked="" type="checkbox"/> PASS <input type="checkbox"/> FAILED
Observation: No any function degraded during the tests.



6. IEC 61000-4-8 (POWER FREQUENCY MAGNETIC FIELD IMMUNITY TEST)

Port	: Enclosure
Basic Standard	: IEC 61000-4-8
Requirements	: 3 A/m
Performance Criteria	: A (Standard Required)
Tester	: Terry Su
Temperature	: N/A
Humidity	: N/A

****Note:** Not applicable, because no any component can be influenced by power magnetic fields.

7. IEC 61000-4-11

(VOLTAGE DIPS, SHORT INTERRUPTIONS AND VOLTAGE VARIATIONS)

VOLTAGE DIPS / SHORT INTERRUPTIONS

Port : AC mains
Basic Standard : IEC 61000-4-11 (1994)
Requirement : PHASE ANGLE 0, 45, 90, 135, 180, 225, 270, 315 degrees

Voltage Dips	Test Level	Reduction	Duration	Performance
	% U_T	(%)	(periods)	Criteria
	<5	>95	0.5	B
	70	30	25	C

Voltage Interceptions	Test Level	Reduction	Duration	Performance
	% U_T	(%)	(periods)	Criteria
	<5	>95	250	C

Test Interval : Min. 10 sec.
Tester : Lung Tsai
Temperature : 23?
Humidity : 53?

Block Diagram of Test Setup:

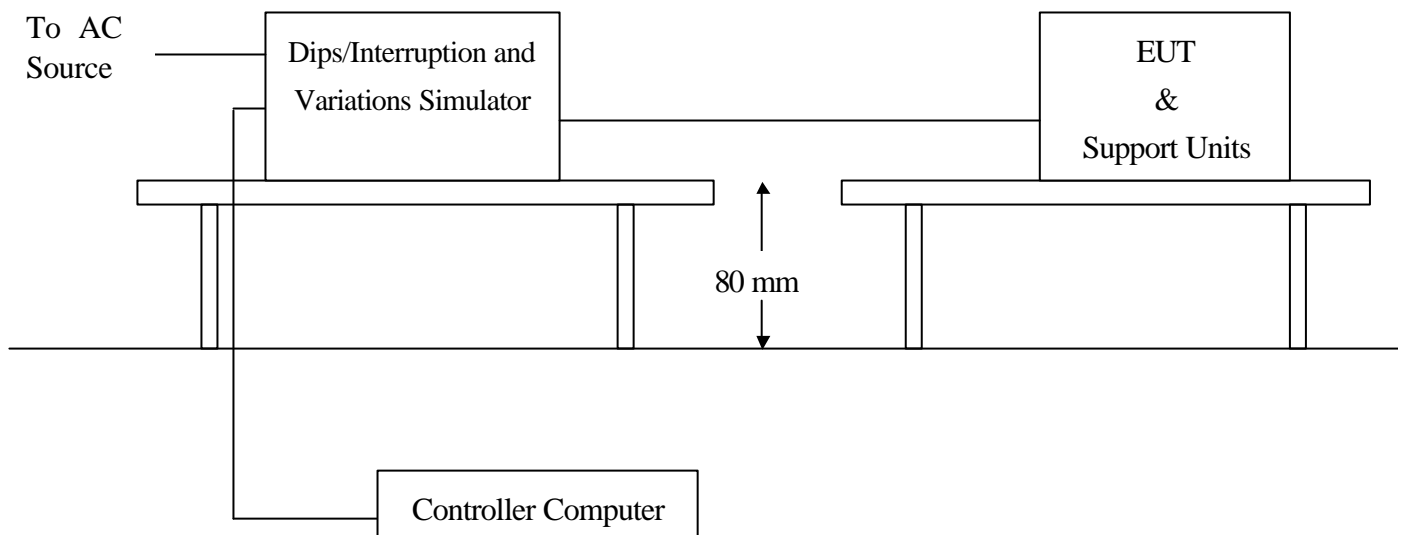



Test Procedure:

1. The EUT and support units were located on a wooden table, 0.8 m away from ground floor.
2. A test program was loaded and executed in Windows mode.
3. The data was sent to EUT filling the screens with upper case of “H” patterns.
4. The test program exercised related support units sequentially.
5. Setting the parameter of tests and then Perform the test software of test simulator.
6. Conditions changes to occur at 0 degree crossover point of the voltage waveform.
7. Repeating step 3 to 4 through the test.
8. Recording the test result in test record form.

Test conditions:

The duration with a sequence of three dips/interruptions with interval of 10 s minimum
(Between each test event)

Voltage Dips:

Test Level % U _T	Reduction (%)	Duration (periods)	Observation	Meet Performance Criteria
0	100	0.5	Normal	A
70	30	25	Normal	A

Voltage Interruptions:

Test Level % U _T	Reduction (%)	Duration (periods)	Observation	Meet Performance Criteria
0	100	250	EUT shut down, but can be auto recovered as the events disappear.	B

Normal: No any functions degrade during and after the test.

Performance & Result:

Criteria A: The apparatus continues to operate as intended. No degradation of performance or loss of function is allowed below a performance level specified by the manufacturer, when the apparatus is used as intended. In some cases the performance level may be replaced by a permissible loss of performance.

Criteria B: The apparatus continues to operate as intended after the test. No degradation of performance or loss of function is allowed below a performance level specified by the manufacturer, when the apparatus is used as intended. In some cases the performance level may be replaced by a permissible loss of performance. During the test, degradation of performance is however allowed.

Criteria C: Temporary loss of function is allowed, provided the functions self recoverable or can be restored by the operation of controls.



<input checked="" type="checkbox"/> PASS	<input type="checkbox"/> FAILED
---	--



APPENDIX 1

PHOTOGRAPHS OF TEST SETUP

LINE CONDUCTED EMISSION TEST (EN 55022)
Front View



Back View

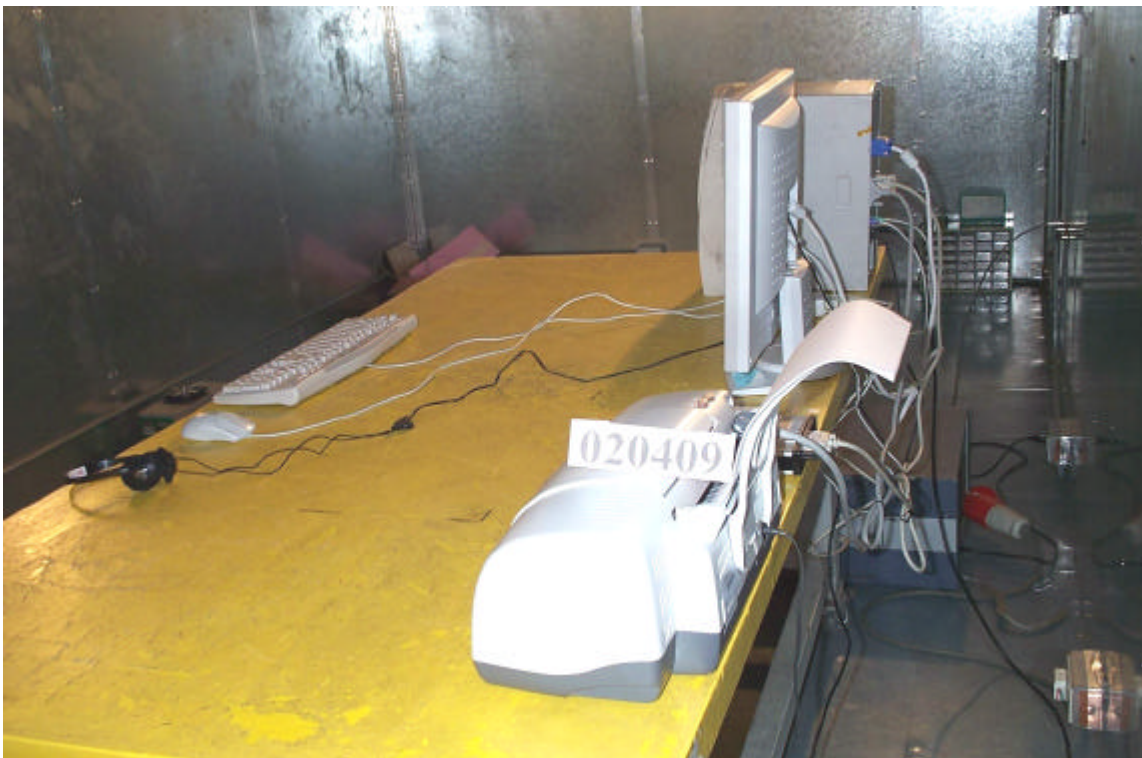

RADIATED EMISSION TEST (EN 55022)

Front View



Back View



***POWER HARMONIC & VOLTAGE FLUCTUATION / FLICKER TEST
(EN 61000-3-2 & EN 61000-3-3)***



ELECTROSTATIC DISCHARGE TEST(IEC 61000-4-2)



RADIATED ELECTROMAGNETIC FIELD (IEC 61000-4-3)



FAST TRANSIENTS/BURST TEST (IEC 61000-4-4)



SURGE IMMUNITY TEST (IEC 61000-4-5)



***CONDUCTED DISTURBANCE, INDUCED BY RADIO-FREQUENCY
FIELDS TEST (IEC 61000-4-6)***



VOLTAGE DIPS / INTERRUPTION TEST (IEC 61000-4-11)





APPENDIX 2

PHOTOGRAPHS OF EUT

Front View of AU



Back View of AU

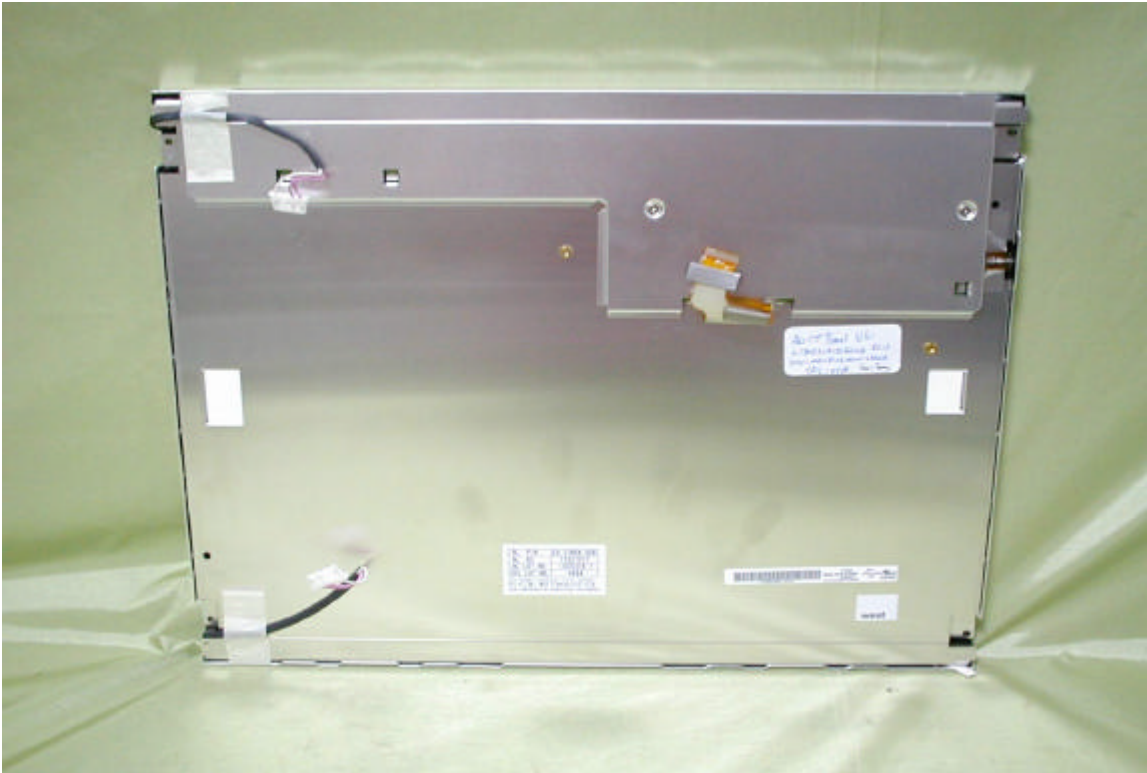

Front View of HYUNDAI



Back View of HYUNDAI

