

# REALTEK

## RTL8169S-32

### INTEGRATED GIGABIT ETHERNET CONTROLLER (NIC)

## DATASHEET

Rev. 1.8

20 June 2005

Track ID: JATR-1076-21



## REALTEK

Realtek Semiconductor Corp.

No. 2, Industry E. Rd. IX, Science-Based Industrial Park, Hsinchu 300, Taiwan

Tel: +886-3-5780211 Fax: +886-3-5776047

[www.realtek.com.tw](http://www.realtek.com.tw)

**COPYRIGHT**

©2005 Realtek Semiconductor Corp. All rights reserved. No part of this document may be reproduced, transmitted, transcribed, stored in a retrieval system, or translated into any language in any form or by any means without the written permission of Realtek Semiconductor Corp.

**TRADEMARKS**

Realtek is a trademark of Realtek Semiconductor Corporation. Other names mentioned in this document are trademarks/registered trademarks of their respective owners.

**DISCLAIMER**

Realtek provides this document “as is”, without warranty of any kind, neither expressed nor implied, including, but not limited to, the particular purpose. Realtek may make improvements and/or changes in this document or in the product described in this document at any time. This document could include technical inaccuracies or typographical errors.

**USING THIS DOCUMENT**

This document is intended for use by the software engineer when programming for the Realtek RTL8169S-32 controller chip. Information pertaining to the hardware design of products using these chips is contained in a separate document.

Though every effort has been made to ensure that this document is current and accurate, more information may have become available subsequent to the production of this guide. In that event, please contact your Realtek representative for additional information that may help in the development process.

**REVISION HISTORY**

Revision	Release Date	Summary
1.0	2003/03/20	First release.
1.1	2003/04/12	Revised pin name and pin assignments.
1.2	2003/06/24	Minor 233-pin TFBGA pin number corrections. IEEE 802.3z changed to IEEE 802.3ab in General Description.
1.3	2003/09/23	Add the voltage variation to DC characteristics.
1.4	2003/09/24	Remove “JTAG support” from the Features section. The RTL8169S does not support JTAG.
1.5	2004/01/16	EEDI/AUX and EEDO description changed in Table 3, page 7.
1.6	2004/02/26	VDD18 parameters changed in Table 12, page 21, and Table 15, page 22.
1.7	2004/08/12	Revised Pin 126 (VDD18A) description (see Table 8, page 9, Table 11, page 21, Table 12, page 21, and Table 15, page 22).
1.8	2005/06/20	Remove RTL8110S-64 support. The RTL8110S-64 is no longer available. Add part numbers for Lead Free and Green Package in Table 20, page 37.

---

## Table of Contents

---

<b>1. GENERAL DESCRIPTION</b> .....	<b>1</b>
<b>2. FEATURES</b> .....	<b>2</b>
<b>3. SYSTEM APPLICATIONS</b> .....	<b>2</b>
<b>4. PIN ASSIGNMENTS</b> .....	<b>3</b>
4.1. PACKAGE IDENTIFICATION .....	3
<b>5. PIN DESCRIPTIONS</b> .....	<b>4</b>
5.1. POWER MANAGEMENT/ISOLATION.....	4
5.2. PCI INTERFACE .....	5
5.3. EEPROM .....	7
5.4. TRANSCEIVER INTERFACE.....	7
5.5. CLOCK .....	8
5.6. REGULATOR & REFERENCE.....	8
5.7. LEDs .....	8
5.8. POWER & GROUND .....	9
5.9. NC (NOT CONNECTED).....	9
<b>6. FUNCTIONAL DESCRIPTION</b> .....	<b>10</b>
6.1. TRANSCEIVER .....	10
6.1.1. <i>Transmitter</i> .....	10
6.1.2. <i>Receiver</i> .....	10
6.2. MAC.....	11
6.3. NEXT PAGE .....	11
6.4. MII/GMII INTERFACE.....	12
6.4.1. <i>MII</i> .....	12
6.4.2. <i>GMII</i> .....	12
6.5. LEDs .....	12
6.5.1. <i>Link Monitor</i> .....	12
6.5.2. <i>RX LED</i> .....	13
6.5.3. <i>TX LED</i> .....	14
6.5.4. <i>TX/RX LED</i> .....	15
6.5.5. <i>LINK/ACT LED</i> .....	16

---

6.6.	FLASH/EEPROM INTERFACE.....	17
6.7.	POWER MANAGEMENT.....	18
<b>7.</b>	<b>CHARACTERISTICS.....</b>	<b>21</b>
7.1.	ABSOLUTE MAXIMUM RATINGS.....	21
7.2.	RECOMMENDED OPERATING CONDITIONS.....	21
7.3.	CRYSTAL REQUIREMENTS.....	21
7.4.	THERMAL CHARACTERISTICS.....	22
7.5.	DC CHARACTERISTICS.....	22
7.6.	AC CHARACTERISTICS.....	23
7.6.1.	<i>Serial EEPROM Interface Timing</i> .....	23
7.7.	PCI BUS OPERATION TIMING.....	24
7.7.1.	<i>PCI Bus Timing Parameters</i> .....	24
7.7.2.	<i>PCI Clock Specification</i> .....	26
7.7.3.	<i>PCI Transactions</i> .....	27
<b>8.</b>	<b>MECHANICAL DIMENSIONS.....</b>	<b>35</b>
8.1.	128-PIN QFP MECHANICAL DIMENSIONS.....	35
8.2.	NOTES FOR 128-PIN QFP DIMENSIONS.....	36
<b>9.</b>	<b>ORDERING INFORMATION.....</b>	<b>37</b>

---

---

## List of Tables

---

TABLE 1. POWER MANAGEMENT/ISOLATION .....	4
TABLE 2. PCI INTERFACE.....	5
TABLE 3. EEPROM .....	7
TABLE 4. TRANSCEIVER INTERFACE .....	7
TABLE 5. CLOCK .....	8
TABLE 6. REGULATOR & REFERENCE .....	8
TABLE 7. LEDES .....	8
TABLE 8. POWER & GROUND.....	9
TABLE 9. NC (NOT CONNECTED).....	9
TABLE 10. FLASH/EEPROM INTERFACE .....	17
TABLE 11. ABSOLUTE MAXIMUM RATINGS .....	21
TABLE 12. RECOMMENDED OPERATING CONDITIONS .....	21
TABLE 13. CRYSTAL REQUIREMENTS.....	21
TABLE 14. THERMAL CHARACTERISTICS.....	22
TABLE 15. DC CHARACTERISTICS.....	22
TABLE 16. EEPROM ACCESS TIMING PARAMETERS .....	23
TABLE 17. PCI BUS TIMING PARAMETERS .....	24
TABLE 18. MEASUREMENT CONDITION PARAMETERS.....	25
TABLE 19. CLOCK AND RESET SPECIFICATIONS .....	26
TABLE 20. ORDERING INFORMATION .....	37

---

---

## List of Figures

---

FIGURE 1. PIN ASSIGNMENTS .....	3
FIGURE 2. RX LED .....	13
FIGURE 3. TX LED .....	14
FIGURE 4. TX/RX LED.....	15
FIGURE 5. LINK/ACT LED .....	16
FIGURE 6. SERIAL EEPROM INTERFACE TIMING .....	23
FIGURE 7. OUTPUT TIMING MEASUREMENT CONDITIONS .....	25
FIGURE 8. INPUT TIMING MEASUREMENT CONDITIONS .....	25
FIGURE 9. 3.3V CLOCK WAVEFORM .....	26
FIGURE 10. CLOCK SKEW DIAGRAM .....	26
FIGURE 11. I/O READ .....	27
FIGURE 12. I/O WRITE.....	27
FIGURE 13. CONFIGURATION READ .....	28
FIGURE 14. CONFIGURATION WRITE .....	29
FIGURE 15. BUS ARBITRATION .....	29
FIGURE 16. MEMORY READ BELOW 4GB (32-BIT ADDRESS, 32-BIT DATA) .....	30
FIGURE 17. MEMORY WRITE BELOW 4GB (32-BIT ADDRESS, 32-BIT DATA).....	31
FIGURE 18. TARGET INITIATED TERMINATION - DISCONNECT.....	31
FIGURE 19. TARGET INITIATED TERMINATION - ABORT .....	32
FIGURE 20. MASTER INITIATED TERMINATION - ABORT .....	32
FIGURE 21. PARITY OPERATION – ONE EXAMPLE .....	33
FIGURE 22. MEMORY READ ABOVE 4GB (DAC, 64-BIT ADDRESS, 32-BIT DATA) .....	34
FIGURE 23. MEMORY WRITE ABOVE 4GB (DAC, 64-BIT ADDRESS, 32-BIT DATA).....	34

---

## 1. General Description

The Realtek RTL8169S-32 Ethernet controller combines a triple-speed IEEE 802.3 compliant Media Access Controller (MAC) with a triple-speed Ethernet transceiver, 32-bit PCI bus controller, and embedded memory. With state-of-the-art DSP technology and mixed-mode signal technology, it offers high-speed transmission over CAT 5 UTP or CAT 3 UTP (10Mbps only) cable. Functions such as Crossover Detection & Auto-Correction, polarity correction, adaptive equalization, cross-talk cancellation, echo cancellation, timing recovery, and error correction are implemented to provide robust transmission and reception capability at high speeds.

The device supports the PCI v2.2 bus interface for host communications with power management, and is compliant with the IEEE 802.3 specification for 10/100Mbps Ethernet and the IEEE 802.3ab specification for 1000Mbps Ethernet. It also supports an auxiliary power auto-detect function, and will auto-configure related bits of the PCI power management registers in PCI configuration space.

To achieve the most efficient power management possible, Advanced Configuration and Power Interface (ACPI) power management support is provided for modern operating systems that are capable of Operating System directed Power Management (OSPM).

In addition to the ACPI feature, the RTL8169S-32 supports remote wake-up (including AMD Magic Packet, Re-LinkOk, and Microsoft<sup>®</sup> Wake-up frame) in both ACPI and APM (Advanced Power Management) environments. The LWAKE pin provides four different output signals including active high, active low, positive pulse, and negative pulse. The versatility of the LWAKE pin provides motherboards with Wake-On-LAN (WOL) functionality. To support WOL from a deep power down state (e.g. D3cold, i.e. main power is off and only auxiliary exists), the auxiliary power source must be able to provide the needed power for the RTL8169S-32.

The RTL8169S is fully compliant with Microsoft<sup>®</sup> NDIS5 (IP, TCP, UDP) Checksum and Segmentation Task-offload features, and supports IEEE 802.1Q Virtual bridged Local Area Network (VLAN). The above features contribute to lowering CPU utilization, especially benefiting performance when in operation on a network server. The devices also boost their PCI performance by supporting PCI Memory Read Line & Memory Read Multiple when transmitting, and Memory Write and Invalidate when receiving. To better qualify for server use, the RTL8169S-32 supports the PCI Dual Address Cycle (DAC) command when the assigned buffers reside at a physical memory address higher than 4 Gigabytes.

## 2. Features

- Integrated 10/100/1000 transceiver
- Auto-Negotiation with Next page capability
- Supports PCI 2.2, 32-bit, 33/66MHz
- Supports pair swap/polarity/skew correction
- Crossover Detection & Auto-Correction
- Wake-on-LAN and remote wake-up support
- Microsoft<sup>®</sup> NDIS5 Checksum Offload (IP, TCP, UDP) and largesend offload support
- Supports Full Duplex flow control (IEEE 802.3x)
- Fully compliant with IEEE 802.3, IEEE 802.3u, IEEE 802.3ab
- Supports IEEE 802.1Q VLAN tagging
- Serial EEPROM and/or Flash support
- 3.3V signaling, 5V PCI I/O tolerant
- Transmit/Receive FIFO (8K/64K) support
- Supports power down/link down power saving
- 128-pin QFP

## 3. System Applications

- Gigabit Ethernet Network Interface Cards/Workstation Cards



## 4. Pin Assignments

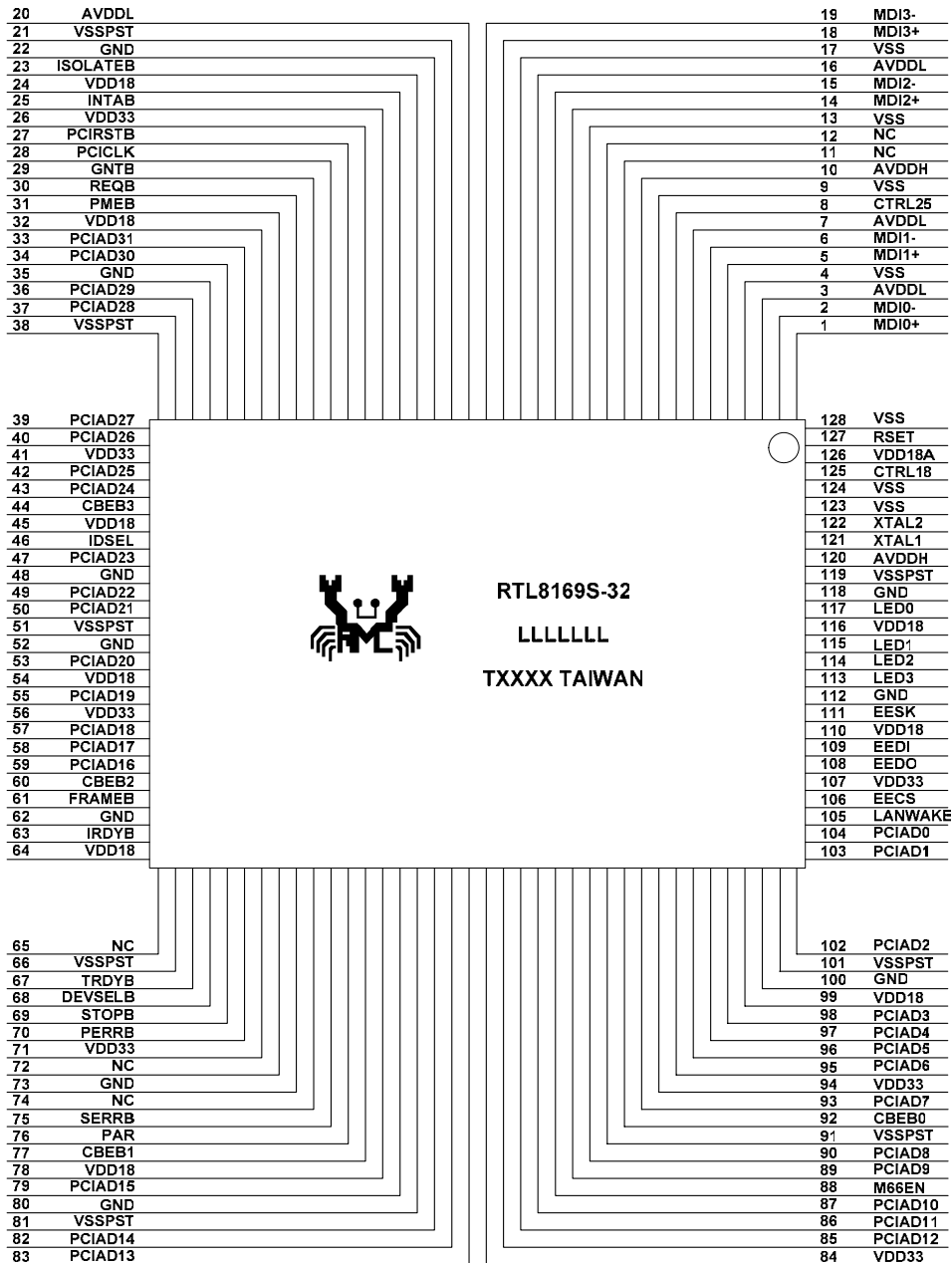

Figure 1. Pin Assignments

### 4.1. Package Identification

Lead (Pb)-free package is indicated by an 'L' in the location marked 'T' in Figure 1.

Green package is indicated by a 'G' in the location marked 'T' in Figure 1.

## 5. Pin Descriptions

The following signal type codes are used in the tables:

I: Input.

O: Output

T/S: Tri-State bi-directional input/output pin.

S/T/S: Sustained Tri-State.

O/D: Open Drain.

### 5.1. Power Management/Isolation

**Table 1. Power Management/Isolation**

Symbol	Type	Pin No.	Description															
PMEB (PME#)	O/D	31	Power Management Event. Open drain, active low. Used to request a change in the current power management state and/or to indicate that a power management event has occurred.															
ISOLATEB (ISOLATE#)	I	23	Isolate Pin. Active low. Used to isolate the RTL8169S from the PCI bus. The RTL8169S will not drive its PCI outputs (excluding PME#) and will not sample its PCI input (including PCIRSTB and PCICLK) as long as the Isolate pin is asserted.															
LANWAKE	O	105	LAN WAKE-UP Signal (When CardB_En=0, bit2 Config3). This signal is used to inform the motherboard to execute the wake-up process. The motherboard must support Wake-On-LAN (WOL). There are 4 choices of output that may be asserted from the LANWAKE pin (active high, active low, positive pulse, and negative pulse). We can configure the LANWAKE output via two CONFIG bits: LWACT (Config1.4) and LWPTN (Config4.2). <table border="1" style="margin: 10px auto;"> <thead> <tr> <th colspan="2">LWAKE Output</th> <th colspan="2">LWACT</th> </tr> <tr> <td colspan="2"></td> <th>0</th> <th>1</th> </tr> </thead> <tbody> <tr> <th rowspan="2">LWPTN</th> <th>0</th> <td>Active high</td> <td>Active low</td> </tr> <tr> <th>1</th> <td>Positive pulse</td> <td>Negative pulse</td> </tr> </tbody> </table> <p>The default output is an active high signal. Once a PME event is received, the LANWAKE and PME# assert at the same time if the LWPME (bit4, CONFIG4) is set to 0. If the LWPME is set to 1, the LANWAKE asserts only when PME# asserts and ISOLATEB is low.</p>	LWAKE Output		LWACT				0	1	LWPTN	0	Active high	Active low	1	Positive pulse	Negative pulse
LWAKE Output		LWACT																
		0	1															
LWPTN	0	Active high	Active low															
	1	Positive pulse	Negative pulse															

## 5.2. PCI Interface

**Table 2. PCI Interface**

Symbol	Type	Pin No.	Description
PCIADPIN31-0	T/S	33, 34, 36, 37, 39, 40, 42, 43, 47, 49, 50, 53, 55, 57, 58, 59, 79, 82, 83, 85, 86, 87, 89, 90, 93, 95, 96, 97, 98, 102, 103, 104	AD31-0: 32-bit PCI address and data multiplexed pins. The address phase is the first clock cycle in which FRAMEB is asserted. During the address phase, AD31-0 contains a physical address (32 bits). For I/O, this is a byte address, and for configuration and memory, it is a double-word address. The RTL8169S supports both big-endian and little-endian byte ordering. Write data is stable and valid when IRDYB is asserted. Read data is stable and valid when TRDYB is asserted. Data I is transferred during those clocks where both IRDYB and TRDYB are asserted. AD16-0: Boot PROM Address Bus. These pins are used to access up to a 128k-byte flash memory or EPROM. AD31-24: Boot PROM data bus during Boot PROM mode.
CBEBPIN3-0	T/S	44, 60, 77, 92	PCI bus command and byte enables multiplexed pins. During the address phase of a transaction, CBEBPIN3-0 defines the bus command. During the data phase, CBEBPIN3-0 are used as Byte Enables. The Byte Enables are valid for the entire data phase and determine which byte lanes carry meaningful data. CBEBPIN0 applies to byte 0, and CBEBPIN3 applies to byte 3.
PCICLK	I	28	PCI Clock. This clock input provides timing for all PCI transactions and is input for the PCI device. Supports up to a 66MHz PCI clock.
DEVSELB	S/T/S	68	Device Select. As a bus master, the RTL8169S samples this signal to ensure that a PCI target recognizes the destination address for the data transfer. As a target, the RTL8169S asserts this signal low when it recognizes its target address after FRAMEB is asserted.
FRAMEB	S/T/S	61	Cycle Frame. As a bus master, this pin indicates the beginning and duration of an access. FRAMEB is asserted low to indicate the start of a bus transaction. While FRAMEB is asserted, data transfer continues. When FRAMEB is de-asserted, the transaction is in the final data phase. As a target, the device monitors this signal before decoding the address to check if the current transaction is addressed to it.
GNTB	I	29	Grant. This signal is asserted low to indicate to the RTL8169S that the central arbiter has granted the ownership of the bus to the RTL8169S. This input is used when the device is acting as a bus master.
REQB	T/S	30	Request. The RTL8169S will assert this signal low to request the ownership of the bus from the central arbiter.
IDSEL	I	46	Initialization Device Select. This pin allows the device to identify when configuration read/write transactions are intended for it.
INTAB	O/D	25	Interrupt A. Used to request an interrupt. It is asserted low when an interrupt condition occurs, as defined by the Interrupt Status, Interrupt Mask.

Symbol	Type	Pin No.	Description
IRDYB	S/T/S	63	Initiator Ready. This indicates the initiating agent's ability to complete the current data phase of the transaction. As a bus master, this signal will be asserted low when the device is ready to complete the current data phase transaction. This signal is used in conjunction with the TRDYB signal. Data transaction takes place at the rising edge of CLK when both IRDYB and TRDYB are asserted low. As a target, this signal indicates that the master has put data on the bus.
TRDYB	S/T/S	67	Target Ready. This indicates the target agent's ability to complete the current phase of the transaction. As a bus master, this signal indicates that the target is ready for the data during write operations, or is ready to provide the data during read operations. As a target, this signal will be asserted low when the (slave) device is ready to complete the current data phase transaction. This signal is used in conjunction with the IRDYB signal. Data transaction takes place at the rising edge of CLK when both IRDYB and TRDYB are asserted low.
PAR	T/S	76	Parity. This signal indicates even parity across PCIADPIN31-0 and CBEB3-0 including the PAR pin. PAR is stable and valid one clock after each address phase. For data phase, PAR is stable and valid one clock after either IRDYB is asserted on a write transaction or TRDYB is asserted on a read transaction. Once PAR is valid, it remains valid until one clock after the completion of the current data phase. As a bus master, PAR is asserted during address and write data phases. As a target, PAR is asserted during read data phases.
M66EN	I	88	66MHZ_ENABLE. This pin indicates to the device whether the bus segment is operating at 66 or 33MHz. When this pin is asserted (active high), the current PCI bus segment that the device resides on operates in 66MHz mode. If this pin is de-asserted, the current PCI bus segment operates in 33MHz mode.
PERRB	S/T/S	70	Parity Error. This pin is used to report data parity errors during all PCI transactions except a Special Cycle. PERRB is driven active (low) two clocks after a data parity error is detected by the device receiving data, and the minimum duration of PERRB is one clock for each data phase with parity error detected.
SERRB	O/D	75	System Error. If an address parity error is detected and Configuration Space Status register bit 15 (detected parity error) is enabled, the device asserts the SERRB pin low and bit 14 of the Status register in Configuration Space.
STOPB	S/T/S	69	Stop. Indicates that the current target is requesting the master to stop the current transaction.
PCIRSTB	I	27	Reset. When PCIRSTB is asserted low, the device performs an internal system hardware reset. PCIRSTB must be held for a minimum period of 120 ns.

### 5.3. EEPROM

**Table 3. EEPROM**

Symbol	Type	Pin No.	Description
EESK	O	111	Serial data clock.
EEDI/AUX	O/I	109	EEDI: Output to serial data input pin of EEPROM. AUX: Input pin to detect if Aux. Power exists or not on initial power-on. This pin should be connected to EEPROM. To support wakeup from ACPI D3cold or APM power-down, this pin must be pulled high to aux. power via a resistor. If this pin is not pulled high to Aux. Power, the RTL8169S assumes that no Aux. Power exists.
EEDO	I	108	Input from serial data output pin of EEPROM.
EECS/BROM CSB	O	106	EECS: EEPROM chip select BROMCSB: This is the chip select signal of the Boot PROM.

### 5.4. Transceiver Interface

**Table 4. Transceiver Interface**

Symbol	Type	Pin No.	Description
MDI[0]+	I/O	1	In MDI mode, this is the first pair in 1000Base-T, i.e. the BI_DA+/- pair, and is the transmit pair in 10Base-T and 100Base-TX. In MDI crossover mode, this pair acts as the BI_DB+/- pair, and is the receive pair in 10Base-T and 100Base-TX.
MDI[0]-	I/O	2	
MDI[1]+	I/O	5	In MDI mode, this is the second pair in 1000Base-T, i.e. the BI_DB+/- pair, and is the transmit pair in 10Base-T and 100Base-TX. In MDI crossover mode, this pair acts as the BI_DA+/- pair, and is the transmit pair in 10Base-T and 100Base-TX.
MDI[1]-	I/O	6	
MDI[2]+	I/O	14	In MDI mode, this is the third pair in 1000Base-T, i.e. the BI_DC+/- pair. In MDI crossover mode, this pair acts as the BI_DD+/- pair.
MDI[2]-	I/O	15	
MDI[3]+	I/O	18	In MDI mode, this is the fourth pair in 1000Base-T, i.e. the BI_DD+/- pair. In MDI crossover mode, this pair acts as the BI_DC+/- pair.
MDI[3]-	I/O	19	

## 5.5. Clock

**Table 5. Clock**

Symbol	Type	Pin No.	Description
Xtal1	I	121	Input of 25MHz clock reference.
Xtal2	O	122	output of 25MHz clock reference.

## 5.6. Regulator & Reference

**Table 6. Regulator & Reference**

Symbol	Type	Pin No.	Description
CTRL25	O	8	Regulator Control. Voltage control to external 2.5V regulator.
CTRL18	O	125	Regulator Control. Voltage control to external 1.8V regulator.
RSET	I	127	Reference. External Resistor Reference.

## 5.7. LEDs

**Table 7. LEDs**

Symbol	Type	Pin No.	Description				
LED0/ BROMO EB	O	117	<b>LEDS1-0</b>	<b>00</b>	<b>01</b>	<b>10</b>	<b>11</b>
			LED0	Tx/Rx	ACT(Tx/Rx)	Tx	LINK10/ ACT
LED1	O	115	LED1	LINK1 00	LINK10/100/1 000	LINK10/100/1 000	LINK100/ ACT
LED2	O	114	LED2	LINK1 0	FULL	Rx	FULL
LED3	O	113	LED3	LINK1 000	-	FULL	LINK1000/A CT

**BROMOEB:** This enables the output buffer of the Boot PROM or Flash memory during a read operation.

Note 1: During power down mode, the LED signals are logic high.

Note 2: LEDSI-0's initial value comes from 93C46/93C56.

## 5.8. Power & Ground

**Table 8. Power & Ground**

Symbol	Type	Pin No.	Description
VDD18A	Power	126	Analog 1.8V power supply.
VDD18	Power	24, 32, 45, 54, 64, 78, 99, 110, 116	Digital 1.8V power supply.
VDD33	Power	26, 41, 56, 71, 84, 94, 107	Digital 3.3V power supply.
GND/VSSPST	Power	21, 22, 35, 38, 48, 51, 52, 62, 66, 73, 80, 81, 91, 100, 101, 112, 118, 119	Digital Ground
AVDDL	Power	3, 7, 16, 20	Analog 2.5V power supply.
AVDDH	Power	10, 120	Analog 3.3V power supply.
VSS	Power	4, 9, 13, 17, 123, 124, 128	Analog Ground

## 5.9. NC (Not Connected)

**Table 9. NC (Not Connected)**

Symbol	Type	Pin No.	Description
NC		11, 12, 65, 72, 74	Not Connected.

## 6. Functional Description

### 6.1. Transceiver

#### 6.1.1. Transmitter

In 10M mode, the Tx MAC retrieves packet data from the Tx Buffer Manager and sends it out through the transmitting physical layer interface. The transmit 4-bit nibbles (TXD[3:0]) clocked at 2.5Mhz (TXC), are serialized into 10Mbps serial data. Then, the 10Mbps serial data is converted into a Manchester-encoded data stream and is transmitted onto the media by the DAC converter.

In 100M mode, the transmitted 4-bit nibbles (TXD[3:0]) from the MAC, clocked at 25Mhz (TXC), are converted into 5B symbol code via 4B/5B coding technology, scrambled and serialized, before being converted to 125Mhz NRZ and NRZI signals. After that, the NRZI signal is passed to the MLT3 encoder, then to the DAC converter for transmission onto the media.

In 1000M mode, the RTL8169S's PCS layer receives data bytes from the MAC through the GMII interface and performs the generation of continuous code-groups through 4D-PAM5 coding technology. Then, those code groups are passed through a waveform shaping filter to minimize EMI effects, and are transmitted onto the 4-pair CAT5 cable at 125MBaud/s through a DAC converter.

#### 6.1.2. Receiver

In MII (10Mbps) mode, the received differential signal is converted into a Manchester-encoded data stream. The stream is processed with a Manchester decoder, and is de-serialized into 4-bit wide nibbles. The 4-bit nibbles are presented to the MII interface at a clock speed of 2.5MHz. In 100Mbps mode, the MLT3 signal is processed with an ADC, equalizer, BLW (Baseline Wander) correction, timing recovery, MLT3 and NRZI decoder, descrambler, 4B/5B decoder, and then is presented to the MII interface in 4-bit wide nibbles at a clock speed of 25MHz.

In GMII mode, the input signal from the media first passes through the on-chip sophisticated hybrid circuit to subtract the transmitted signal from the input signal for effective reduction of near-end echo. The received signal is processed with adaptive equalization, BLW (Baseline Wander) correction, cross-talk cancellation, echo cancellation, timing recovery, error correction, and 4D-PAM5 decoding. Then, the 8-bit wide data is recovered and is sent to the GMII interface at a clock speed of 125MHz. The Rx MAC retrieves the packet data from the receive MII/GMII interface and sends it to the Rx Buffer Manager.



## **6.2. MAC**

The RTL8169S supports new descriptor-based buffer management that significantly reduces host CPU utilization and is particularly effective in server applications. The new buffer management algorithm provides Microsoft Large-Send offload, IP checksum offload, TCP checksum offload, UDP checksum offload, and IEEE 802.1P, 802.1Q VLAN tagging capabilities. The device supports up to 1024 consecutive descriptors in memory for transmit and receive separately, which means there might be 3 descriptor rings, one a high priority transmit descriptor ring, another a normal priority transmit descriptor ring, and the other a receive descriptor ring. Each descriptor ring may consist of up to 1024 consecutive descriptors. Each descriptor consists of 4 consecutive double words. The start address of each descriptor ring should be 256-byte aligned. Software must pre-allocate enough buffers and configure all descriptor rings before transmitting and/or receiving packets. Descriptors can be chained to form a packet in both Tx and Rx. Refer to the Realtek RTL8169S Programming Guide for detailed information. Any Tx buffers pointed to by the Tx descriptors should be at least 4 bytes.

The RTL8169S will automatically pad any packets less than 64 bytes to 64-bytes long (including a 4-byte CRC) before transmitting that packet onto the network medium. If a packet consists of two or more descriptors, then the descriptors in command mode should have the same configuration, except EOR, FS, or LS bits.

## **6.3. Next Page**

If 1000Base-T mode is advertised, three additional Next Pages are automatically exchanged between the two link partners. Users can set Reg4.15 to 1 to exchange extra Next Pages via Reg7 and Reg8 as defined in IEEE 802.3ab.

## **6.4. MII/GMII Interface**

### **6.4.1. MII**

The RTL8169S supports 10Mbps and 100Mbps link operation. During the operation, the PHY communicates with the MAC through the MII as defined in the IEEE 802.3 (clause 22) specifications. The MII consists of a transmit data interface (TxEN, TxER, TXD[3:0], and TxCLK), a receive data interface (RxDV, RxER, RXD[3:0], and RxCLK), two status signals (CRS and COL) and a management interface (MDC and MDIO). In this mode of operation, both Transmit and Receive clocks are supplied by the PHY.

### **6.4.2. GMII**

In 1000Base-T mode, the GMII interface is selected, the 125MHz transmit clock is expected on GTXCLK, TXCLK sources 25MHz, 2.5MHz, or 0MHz clock depending on the operation mode, and RXCLK sources the 125MHz receive clock.

## **6.5. LEDs**

The RTL8169S supports four LED signals in four different configurable operation modes. The modes are shown in Table 7, page 8.

### **6.5.1. Link Monitor**

The Link Monitor senses a link, such as LINK10, LINK100, LINK1000, LINK10/100/1000. Whenever a link is established, the specific link LED pin is driven low. Once disconnected, the link LED pin is driven high indicating that no network connection exists.

### 6.5.2. RX LED

In 10/100/1000Mbps mode, blinking of the Rx LED indicates that receive activity is occurring.

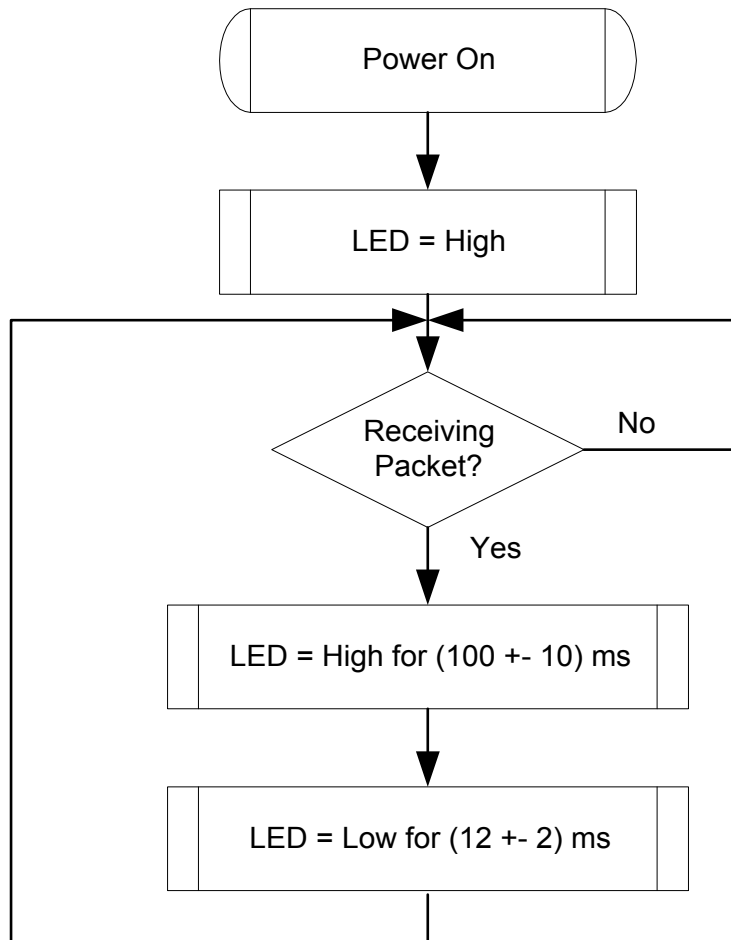

**Figure 2. RX LED**

### 6.5.3. TX LED

In 10/100/1000Mbps mode, blinking of the Tx LED indicates that transmit activity is occurring.

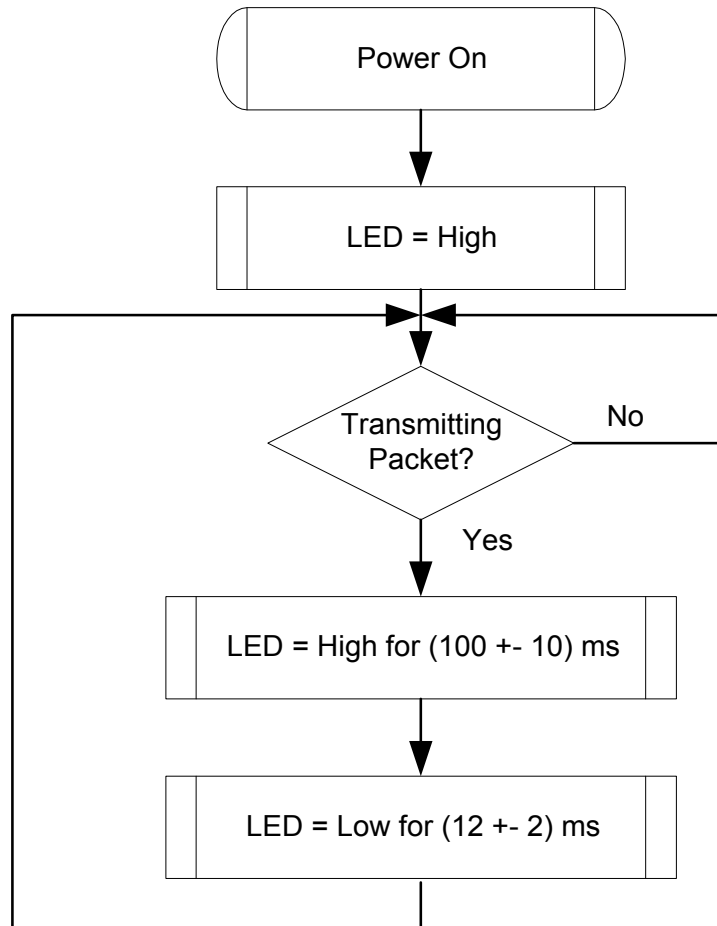
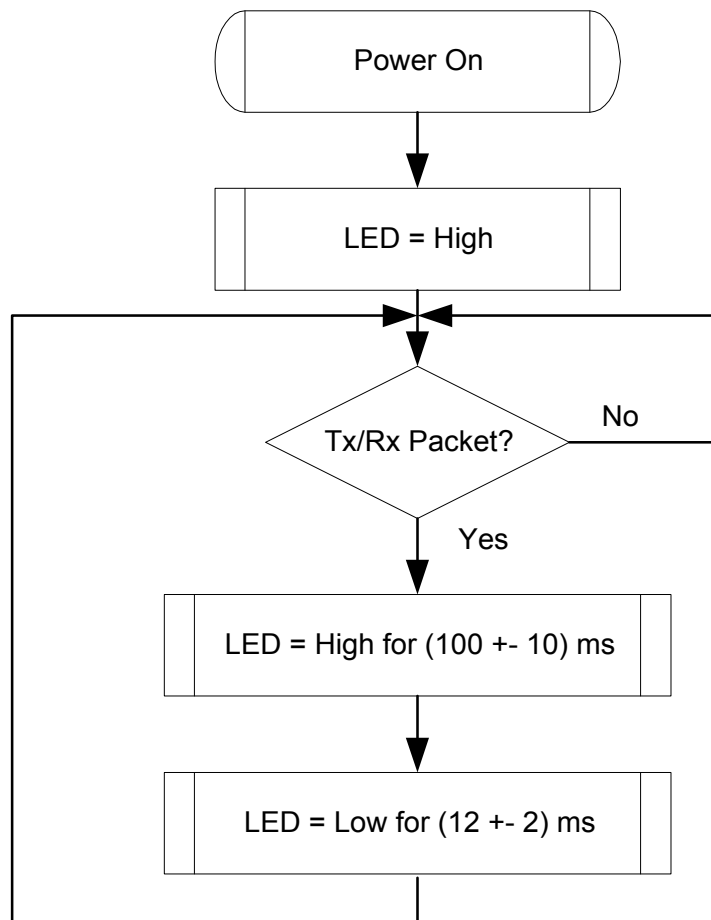

Figure 3. TX LED

#### 6.5.4. TX/RX LED

In 10/100/1000Mbps mode, blinking of the Tx/Rx LED indicates that both transmit and receive activity is occurring.



**Figure 4. TX/RX LED**

### 6.5.5. LINK/ACT LED

In 10/100/1000Mbps mode, blinking of the LINK/ACT LED indicates that the RTL8169S is linked and operating properly. When this LED is high for extended periods, it indicates that a link problem exists.

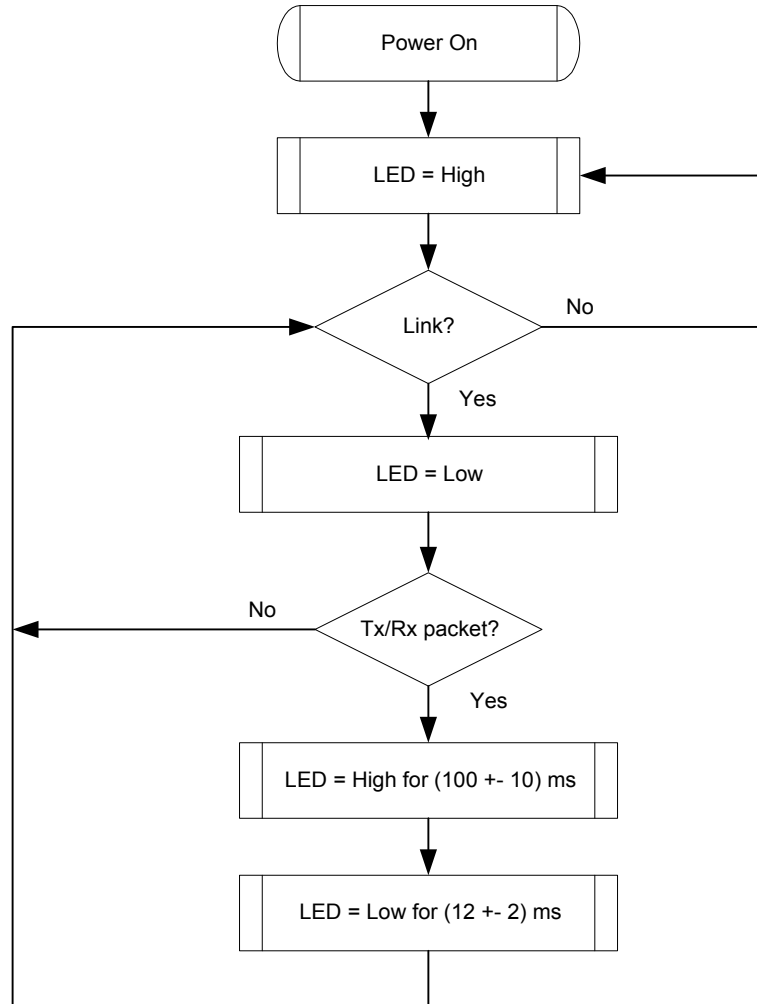

**Figure 5. LINK/ACT LED**

## 6.6. Flash/EEPROM Interface

The Flash interface consists of address bus MA(16:0) and data bus MD(7:0) which share the pin with PCI interface AD(16:0) and AD(32:24), respectively. It also consists of several control signals: WEB, OEB(LED0), CSB(E ECS). The RTL8169S supports the attachment of an external EEPROM. The 93C46 is a 1K-bit EEPROM (the 93C56 is a 2K-bit EEPROM).

The EEPROM interface provides the ability for the RTL8169S to read from and write data to an external serial EEPROM device. Values in the external EEPROM allow default fields in PCI configuration space and I/O space to be overridden following a reboot or software EEPROM auto load command. The RTL8169S will auto load values from the EEPROM. If the EEPROM is not present, the RTL8169S initialization uses default values for the appropriate Configuration and Operational Registers. Software can read and write to the EEPROM using ‘bit-bang’ accesses via the 9346CR Register. The interface consists of EESK, EECS, EEDO, and EEDI.

**Table 10. Flash/EEPROM Interface**

<b>Flash</b>	<b>Description</b>
MA[16:0] (PCIAD16:0)	Boot PROM Address Bus. These pins are used to access up to a 128k-byte flash memory or EEPROM.
MD7-0(PCIAD31:24)	Boot PROM data bus when in Boot PROM mode.
CSB(E ECS/BROMCSB)	The chip select signal of the Boot PROM.
OEB(LED0/BROMOEB)	Enables the output buffer of the Boot PROM or Flash memory during a read operation.
<b>EEPROM</b>	<b>Description</b>
EECS	93C46 (93C56) chip select
EESK	EEPROM serial data clock
EEDI/Aux	Input data bus/Input pin to detect if Aux. Power exists or not on initial power-on. This pin should be connected to Boot PROM. To support wakeup from ACPI D3cold or APM power-down, this pin must be pulled high to aux. power via a resistor. If this pin is not pulled high to Aux. Power, the RTL8169S assumes that no Aux. Power exists.
EEDO	Output data bus

## 6.7. Power Management

The RTL8169S is compliant with ACPI (Rev 1.0, 1.0b, 2.0), PCI Power Management (Rev 1.1), and Network Device Class Power Management Reference Specification (V1.0a), such as to support an OS-directed Power Management (OSPM) environment.

The RTL8169S can monitor the network for a Wakeup Frame, a Magic Packet, or a Re-LinkOk, and notify the system via PME# when such a packet or event occurs. Then, the whole system can be restored to a normal state to process incoming jobs.

When the RTL8169S is in power down mode (D1 ~ D3):

- The Rx state machine is stopped, and the RTL8169S monitors the network for wakeup events such as a Magic Packet, Wakeup Frame, and/or Re-LinkOk, in order to wake up the system. When in power down mode, the RTL8169S will not reflect the status of any incoming packets in the ISR register and will not receive any packets into the Rx FIFO buffer.
- The FIFO status and packets that have already been received into the Rx FIFO before entering power down mode are held by the RTL8169S.
- Transmission is stopped. PCI bus master mode is stopped. The Tx FIFO buffer is held.
- After restoration to a D0 state, the RTL8169S transfers data that was not moved into the Tx FIFO buffer during power down mode. Packets that were not transmitted completely last time are re-transmitted.

The D3cold\_support\_PME bit (bit15, PMC register) and the Aux\_I\_b2:0 bits (bit8:6, PMC register) in PCI configuration space depend on the existence of Aux power (bit15, PMC) = 1.

If EEPROM D3cold\_support\_PME bit (bit15, PMC) = 0, the above 4 bits are all 0's.

Example:

### **If EEPROM D3c\_support\_PME = 1:**

- If Aux. power exists, then PMC in PCI config space is the same as EEPROM PMC (if EEPROM PMC = C2 F7, then PCI PMC = C2 F7).
- If Aux. power is absent, then PMC in PCI config space is the same as EEPROM PMC except the above 4 bits are all 0's (if EEPROM PMC = C2 F7, the PCI PMC = 02 76).

In the above case, if wakeup support is desired when main power is off, it is suggested that the EEPROM PMC be set to C2 F7 (Realtek EEPROM default value).



**If EEPROM D3c\_support\_PME = 0:**

- If Aux. power exists, then PMC in PCI config space is the same as EEPROM PMC (if EEPROM PMC = C2 77, then PCI PMC = C2 77).
- If Aux. power is absent, then PMC in PCI config space is the same as EEPROM PMC except the above 4 bits are all 0's (if EEPROM PMC = C2 77, then PCI PMC = 02 76).

In the above case, if wakeup support is not desired when main power is off, it is suggested that the EEPROM PMC be set to 02 76.

Link Wakeup occurs only when the following conditions are met:

- The LinkUp bit (CONFIG3#4) is set to 1, the PMEn bit (CONFIG1#0) is set to 1, and the PME# can be asserted in the current power state.
- The Link status is re-established.

Magic Packet Wakeup occurs only when the following conditions are met:

- The destination address of the received Magic Packet is acceptable to the RTL8169S, e.g. a broadcast, multicast, or unicast packet addressed to the current RTL8169S adapter.
- The received Magic Packet does not contain a CRC error.
- The Magic bit (CONFIG3#5) is set to 1, the PMEn bit (CONFIG1#0) is set to 1, and the PME# can be asserted in the current power state.
- The Magic Packet pattern matches, i.e. 6 \* FFh + MISC (can be none) + 16 \* DID (Destination ID) in any part of a valid (Fast) Ethernet packet.

A Wakeup Frame event occurs only when the following conditions are met:

- The destination address of the received Wakeup Frame is acceptable to the RTL8110S, e.g. a broadcast, multicast, or unicast address to the current RTL8110S adapter.
- The received Wakeup Frame does not contain a CRC error.
- The PMEn bit (CONFIG1#0) is set to 1.
- The 16-bit CRC\* of the received Wakeup Frame matches with the 16-bit CRC\* of the sample Wakeup Frame pattern given by the local machine's OS. Or, the RTL8169S is configured to allow direct packet wakeup, e.g. a broadcast, multicast, or unicast network packet.

\*16-bit CRC: The RTL8169S supports two normal wakeup frames (covering 64 mask bytes from offset 0 to 63 of any incoming network packet) and three long wakeup frames (covering 128 mask bytes from offset 0 to 127 of any incoming network packet).

The PME# signal is asserted only when the following conditions are met:

- The PMEn bit (bit0, CONFIG1) is set to 1.
- The PME\_En bit (bit8, PMCSR) in PCI Configuration Space is set to 1.
- The RTL8169S may assert PME# in the current power state or in isolation state, depending on the PME\_Support (bit15-11) setting of the PMC register in PCI Configuration Space.
- A Magic Packet, LinkUp, or Wakeup Frame has been received.
- Writing a 1 to the PME\_Status (bit15) of the PMCSR register in the PCI Configuration Space clears this bit and causes the RTL8169S to stop asserting a PME# (if enabled).

When the device is in power down mode, e.g. D1-D3, the IO, MEM, and Boot ROM spaces are all disabled. After a RST# assertion, the device's power state is restored to D0 automatically if the original power state was D3<sub>cold</sub>. There is no hardware delay at the device's power state transition. When in ACPI mode, the device does not support PME (Power Management Enable) from D0 (this is the Realtek default setting of the PMC register auto loaded from EEPROM). The setting may be changed from the EEPROM, if required). The RTL8169S also supports the legacy LAN WAKE-UP function. The LWAKE pin is used to notify legacy motherboards to execute the wake-up process whenever the device receives a wakeup event, such as a Magic Packet.

The LWAKE signal is asserted according to the following settings:

1. LWPME bit (bit4, CONFIG4):
  - LWAKE can only be asserted when PMEB is asserted and ISOLATEB is low.
  - LWAKE is asserted whenever a wakeup event occurs.
2. Bit1 of DELAY byte (offset 1Fh, EEPROM):
  - LWAKE signal is enabled.
  - LWAKE signal is disabled.

## 7. Characteristics

### 7.1. Absolute Maximum Ratings

**WARNING:** Absolute maximum ratings are limits beyond which permanent damage may be caused to the device, or device reliability will be affected. All voltages are specified reference to GND unless otherwise specified.

**Table 11. Absolute Maximum Ratings**

Description/Symbol	Minimum	Maximum	Unit
Supply Voltage (VDD33, AVDDH)	-0.5	4	V
Supply Voltage (VDD25)	-0.5	3	V
Supply Voltage (VDD18, VDD18A)	-0.5	2	V
Input Voltage (DCinput)	-0.5	VDD33 + 0.5	V
Output Voltage (DCoutput)	-0.5	VDD33 + 0.5	V
Storage Temperature	-55	+125	°C

### 7.2. Recommended Operating Conditions

**Table 12. Recommended Operating Conditions**

Description	Pins	Minimum	Typical	Maximum	Unit
Supply Voltage VDD	VDD33, AVDDH	3.0	3.3	3.6	V
	VDD25	2.25	2.5	2.75	V
	VDD18, VDD18A	1.6	1.8	2.0	V
Ambient Temperature T <sub>A</sub>		0		70	°C
Maximum Junction Temperature				125	°C

### 7.3. Crystal Requirements

**Table 13. Crystal Requirements**

Symbol	Description/Condition	Minimum	Typical	Maximum	Unit
F <sub>ref</sub>	Parallel resonant crystal reference frequency, fundamental mode, AT-cut type.		25		MHz
F <sub>ref</sub> Stability	Parallel resonant crystal frequency stability, fundamental mode, AT-cut type. T <sub>a</sub> =25°C.	-50		+50	ppm
F <sub>ref</sub> Tolerance	Parallel resonant crystal frequency tolerance, fundamental mode, AT-cut type. T <sub>a</sub> =-20°C ~+70°C.	-30		+30	ppm
F <sub>ref</sub>	Reference clock input duty cycle.	40		60	%

Symbol	Description/Condition	Minimum	Typical	Maximum	Unit
Duty Cycle					
$C_L$	Load Capacitance.			27	pF
ESR	Equivalent Series Resistance.			10	$\Omega$
DL	Drive Level.			0.5	mW

## 7.4. Thermal Characteristics

**Table 14. Thermal Characteristics**

Parameter	Minimum	Maximum	Units
Storage Temperature	-55	+125	$^{\circ}\text{C}$
Ambient Operating Temperature	0	70	$^{\circ}\text{C}$

## 7.5. DC Characteristics

**Table 15. DC Characteristics**

Symbol	Parameter	Conditions	Minimum	Typical	Maximum	Units
VDD33	3.3V Supply Voltage		3.0	3.3	3.6	V
VDD18, VDD18A	1.8V Supply Voltage		1.6	1.8	2.0	V
VDD25	2.5V Supply Voltage		2.25	2.5	2.75	V
$V_{oh}$	Minimum High Level Output Voltage	$I_{oh} = -8\text{mA}$	$0.9 * V_{cc}$		$V_{cc}$	V
$V_{ol}$	Maximum Low Level Output Voltage	$I_{ol} = 8\text{mA}$			$0.1 * V_{cc}$	V
$V_{ih}$	Minimum High Level Input Voltage		$0.5 * V_{cc}$		$V_{cc}+0.5$	V
$V_{il}$	Maximum Low Level Input Voltage		-0.5		$0.3 * V_{cc}$	V
$I_{in}$	Input Current	$V_{in} = V_{cc}$ or GND	-1.0		1.0	$\mu\text{A}$
$I_{oz}$	Tri-State Output Leakage Current	$V_{out} = V_{cc}$ or GND	-10		10	$\mu\text{A}$
$I_{cc33}$	Average Operating Supply Current from 3.3V	At 1Gbps with heavy network traffic		170		mA
$I_{cc18}$	Average Operating Supply Current from 1.8V	At 1Gbps with heavy network traffic		660		mA

## 7.6. AC Characteristics

### 7.6.1. Serial EEPROM Interface Timing

93C46(64\*16)/93C56(128\*16)

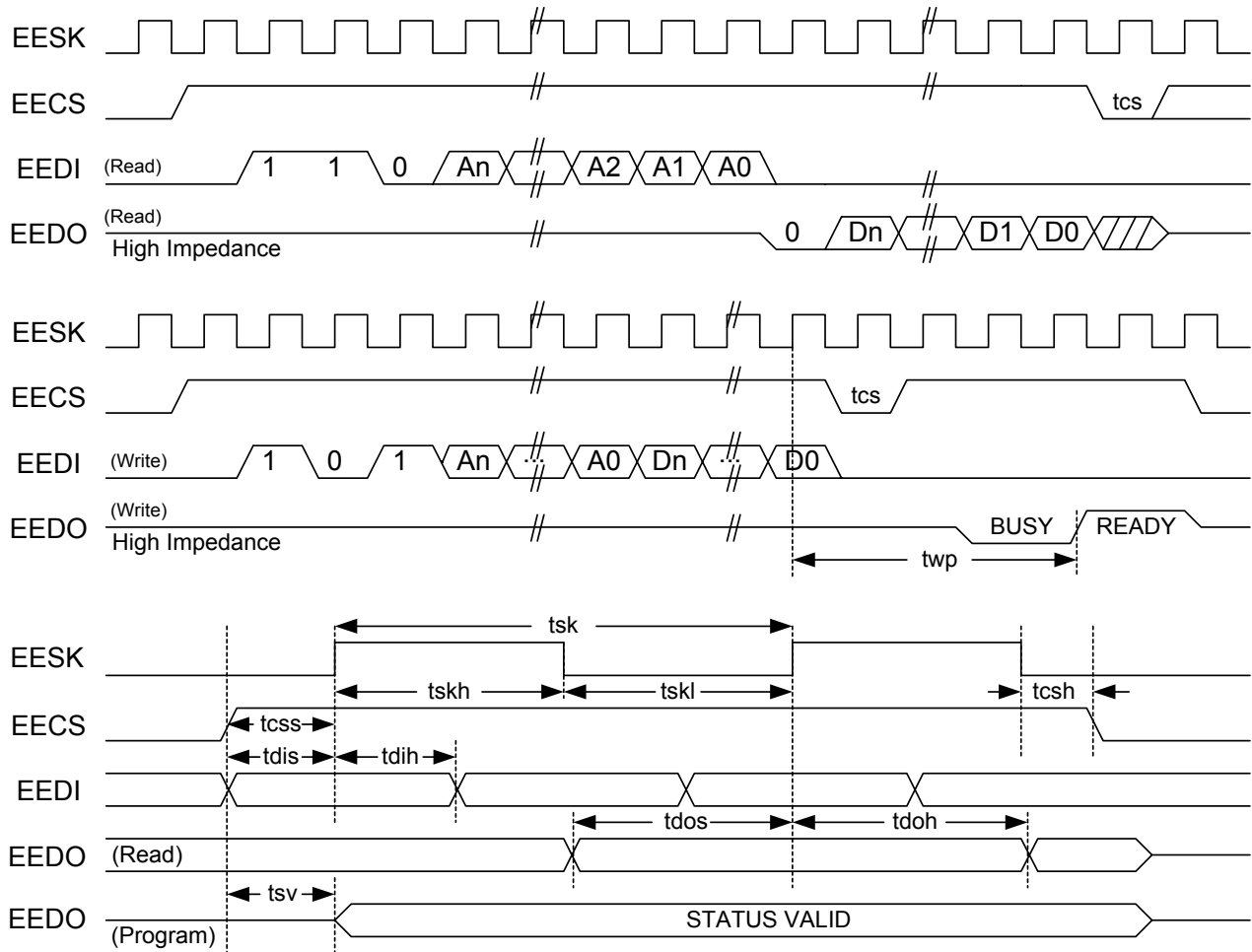

**Figure 6. Serial EEPROM Interface Timing**

**Table 16. EEPROM Access Timing Parameters**

Symbol	Parameter	EEPROM Type	Min.	Max.	Unit
tcs	Minimum CS Low Time	9346/9356	1000/250		ns
twp	Write Cycle Time	9346/9356		10/10	ms
tsk	SK Clock Cycle Time	9346/9356	4/1		μs
tskh	SK High Time	9346/9356	1000/500		ns
tskl	SK Low Time	9346/9356	1000/250		ns
tcss	CS Setup Time	9346/9356	200/50		ns

Symbol	Parameter	EEPROM Type	Min.	Max.	Unit
tcs	CS Hold Time	9346/9356	0/0		ns
tdis	DI Setup Time	9346/9356	400/50		ns
tdih	DI Hold Time	9346/9356	400/100		ns
tdos	DO Setup Time	9346/9356	2000/500		ns
tdoh	DO Hold Time	9346/9356		2000/500	ns
tsv	CS to Status Valid	9346/9356		1000/500	ns

## 7.7. PCI Bus Operation Timing

### 7.7.1. PCI Bus Timing Parameters

Table 17. PCI Bus Timing Parameters

Symbol	Parameter	66MHz		33MHz		Parameter
		Min	Max	Min	Symbol	
T val	CLK to Signal Valid Delay-based signals	2	6	2	11	ns
T val (ptp)	CLK to Signal Valid Delay-point to point	2	6	2	12	ns
T on	Float to Active Delay	2		2		ns
T off	Active to Float Delay		14		28	ns
T su	Input Setup Time to CLK-based signals	3		7		ns
T su (ptp)	Input Setup Time to CLK-point to point	5		10		ns
T h	Input Hold Time from CLK	0		0		ns
T rst	Reset active time after power stable	1		1		ms
T rst-clk	Reset active time after CLK STABLE	100		100		μs
T rst-off	Reset Active to Output Float delay		40		40	ns
T rhfa	RSTB High to First configuration Access	2 <sup>25</sup>		2 <sup>25</sup>		clocks
T rhff	RSTB High to First FRAMEB assertion	5		5		clocks

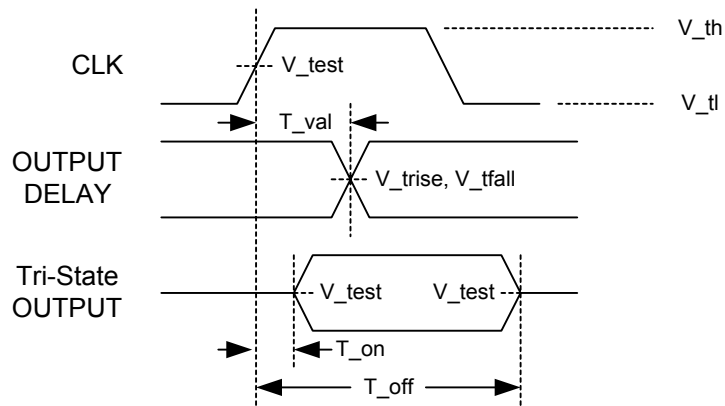

**Figure 7. Output Timing Measurement Conditions**

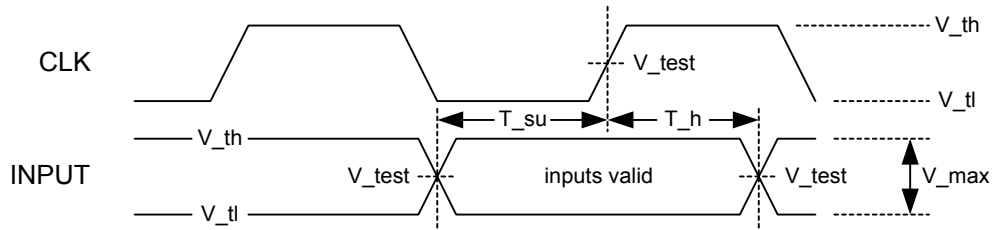
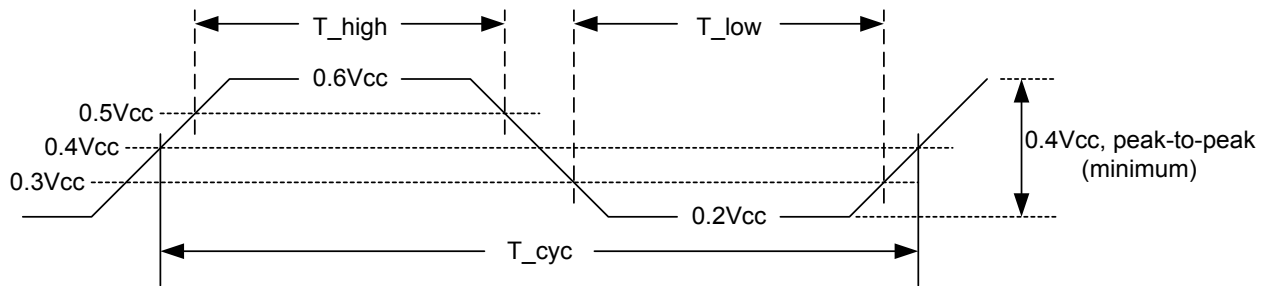

**Figure 8. Input Timing Measurement Conditions**

**Table 18. Measurement Condition Parameters**

Symbol	Level	Units
V <sub>th</sub>	0.6V <sub>cc</sub>	V
V <sub>tl</sub>	0.2V <sub>cc</sub>	V
V <sub>test</sub>	0.4V <sub>cc</sub>	V
V <sub>trise</sub>	0.285V <sub>cc</sub>	V
V <sub>tfall</sub>	0.615V <sub>cc</sub>	V
V <sub>max</sub>	0.4V <sub>cc</sub>	V
Input Signal Edge Rate	1	V/ns

### 7.7.2. PCI Clock Specification



**Figure 9. 3.3V Clock Waveform**

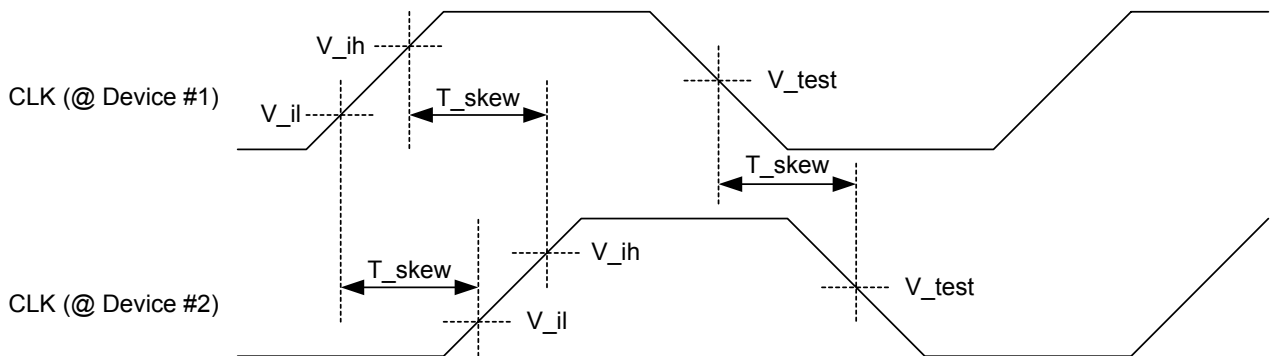
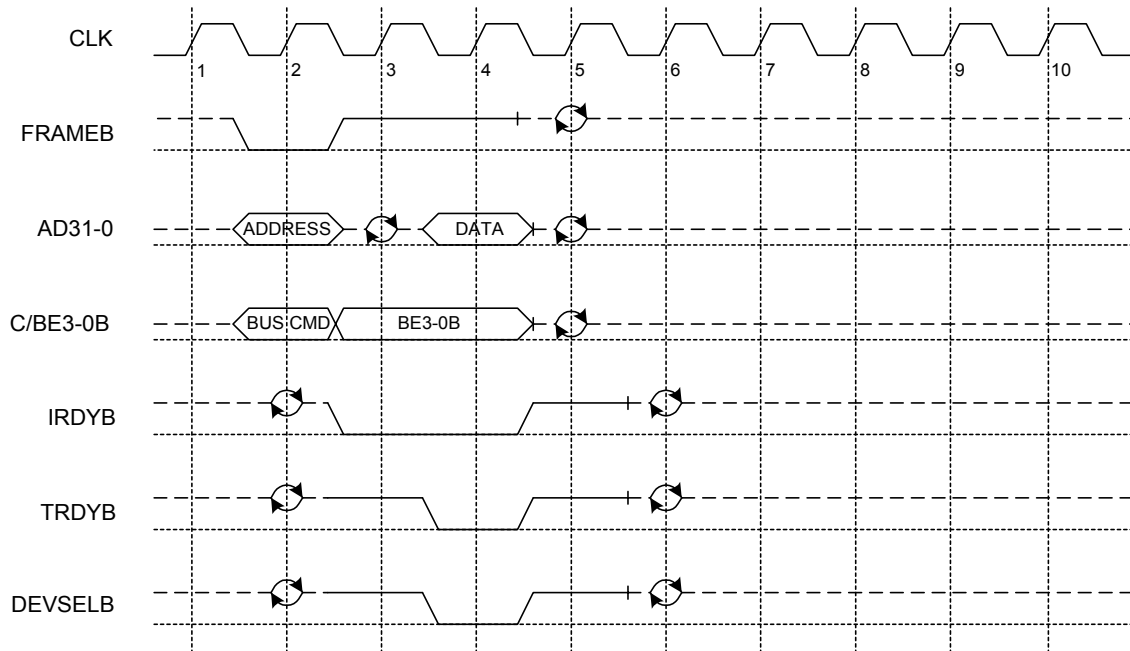
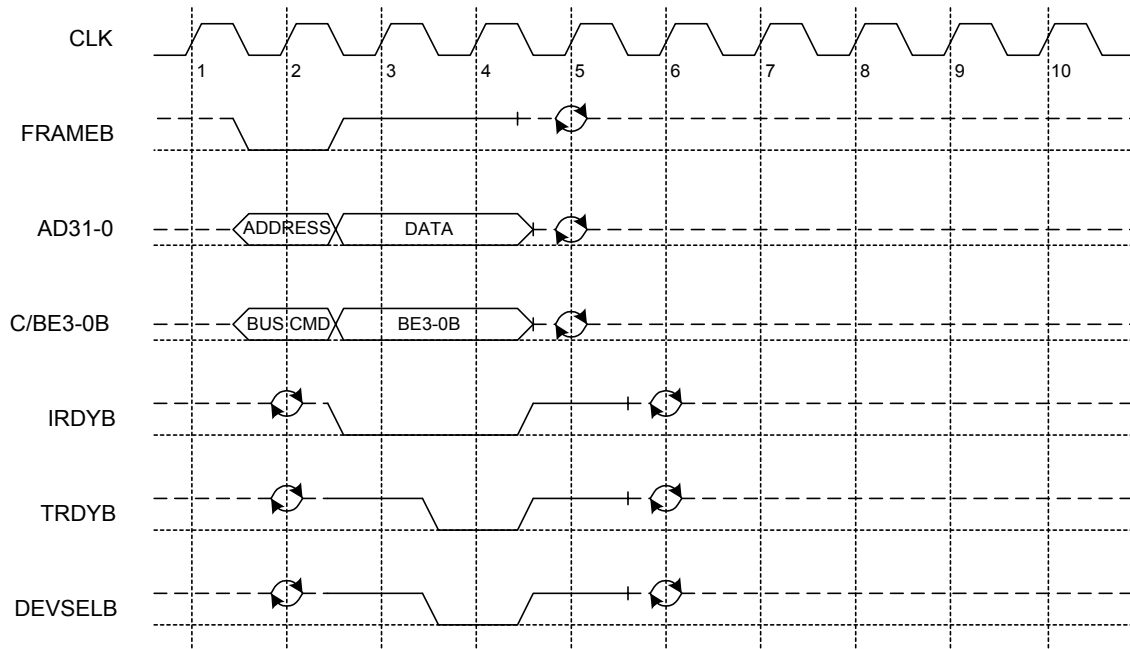

**Figure 10. Clock Skew Diagram**

**Table 19. Clock and Reset Specifications**

Symbol	Parameter	66MHz		33MHz		Parameter
		Min	Max	Min	Symbol	
T <sub>cyc</sub>	CLK Cycle Time	15	30	30	∞	ns
T <sub>high</sub>	CLK High Time	6		11		ns
T <sub>low</sub>	CLK Low Time	6		11		ns
--	CLK Slew Rate	1.5	4	1	4	V/ns
--	RST# Slew Rate	50	-	50	-	mV/ns
T <sub>skew</sub>	CLK Skew		1		2	ns

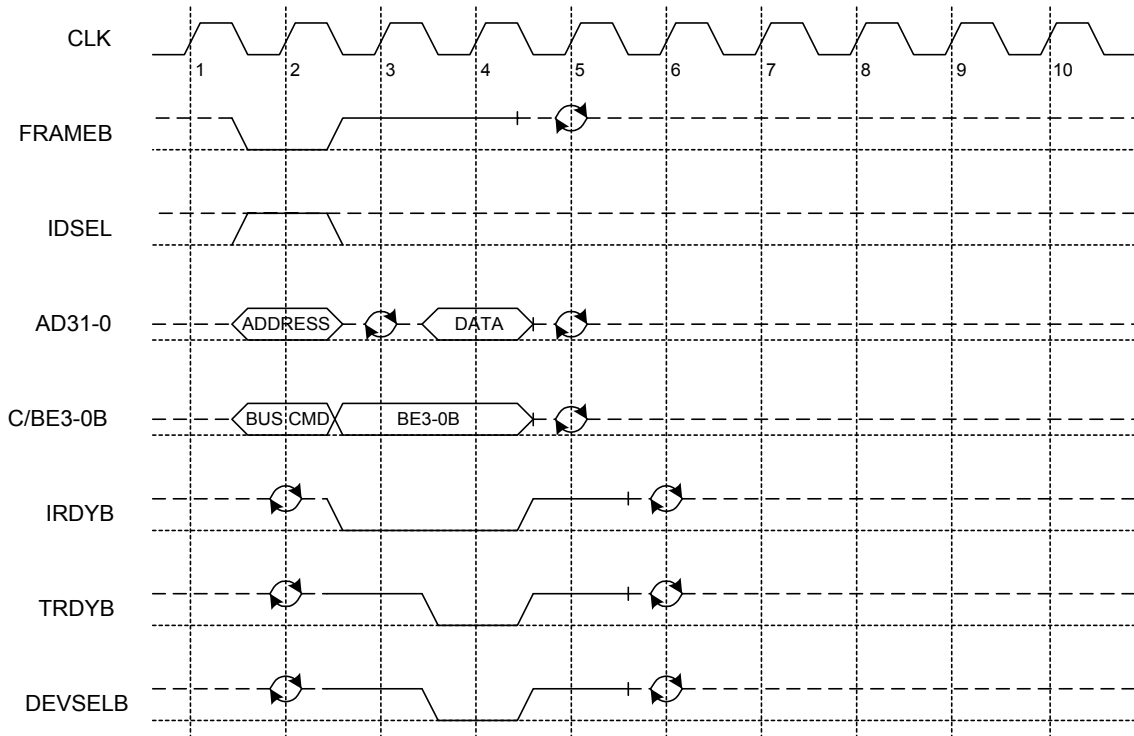

**7.7.3. PCI Transactions**

**Figure 11. I/O Read**

**Figure 12. I/O Write**

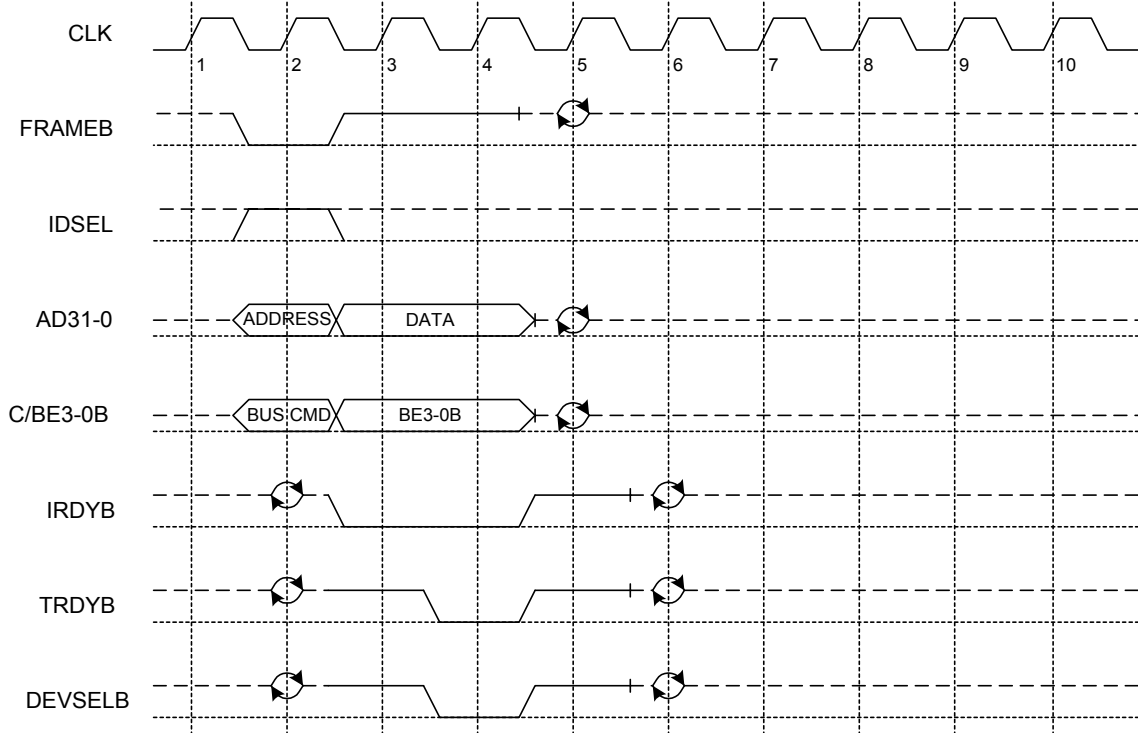

**Figure 13. Configuration Read**

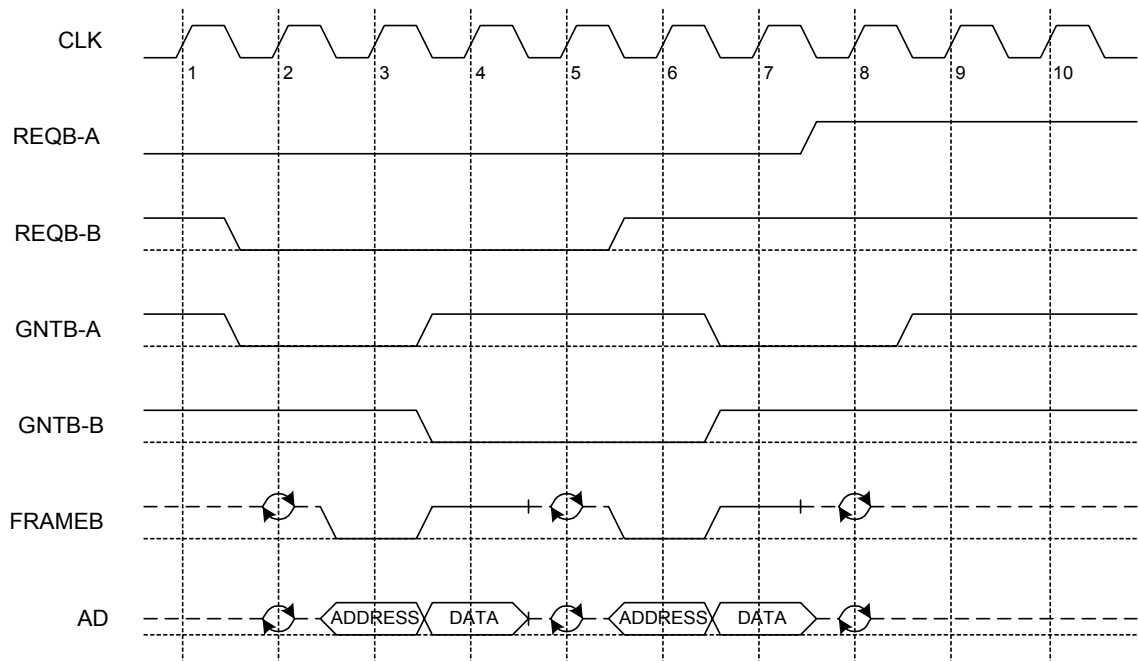

**Figure 14. Configuration Write**



**Figure 15. Bus Arbitration**

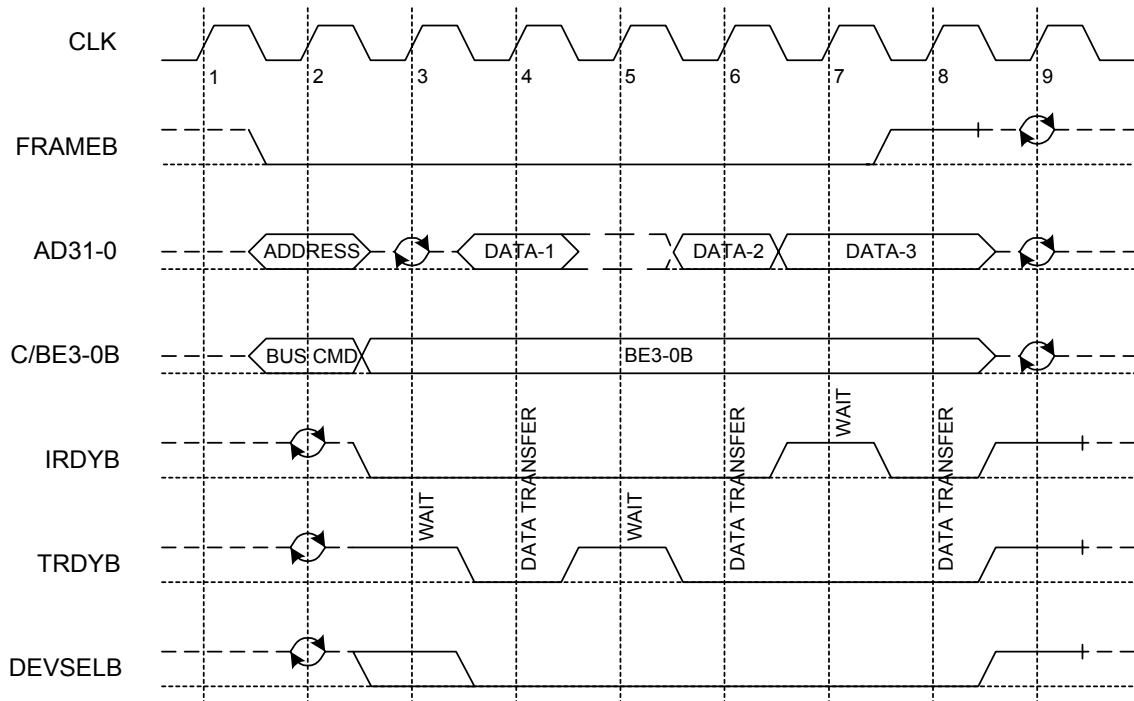

**Figure 16. Memory Read below 4GB (32-bit address, 32-bit data)**

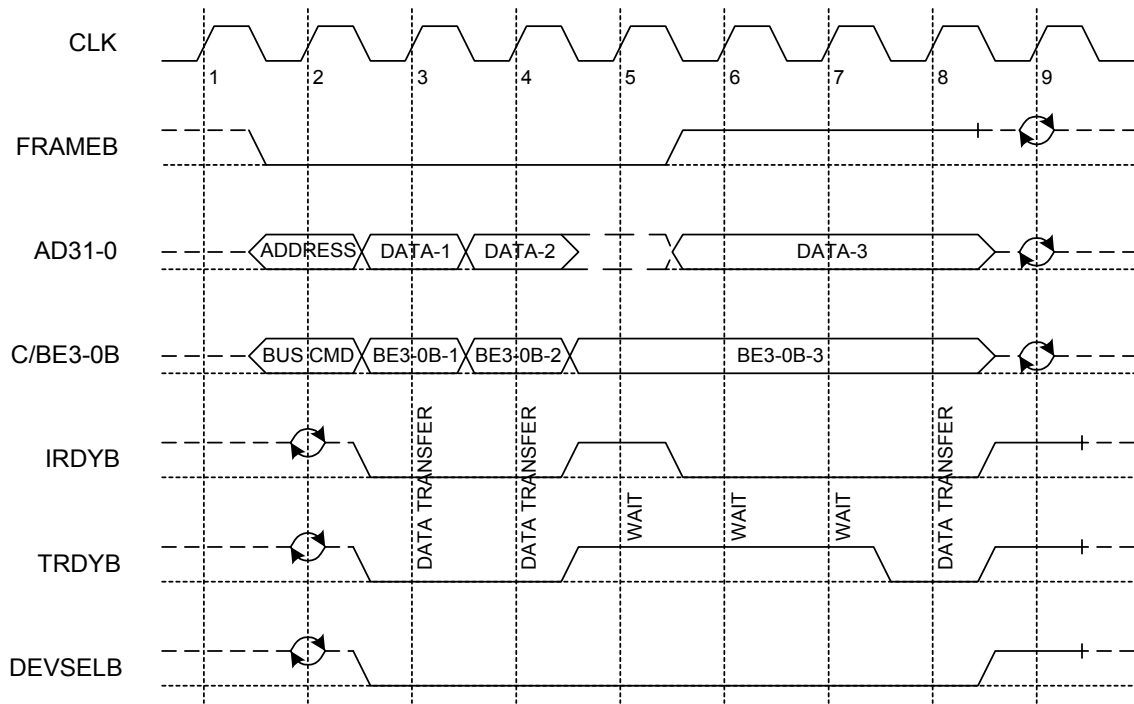

**Figure 17. Memory Write below 4GB (32-bit address, 32-bit data)**

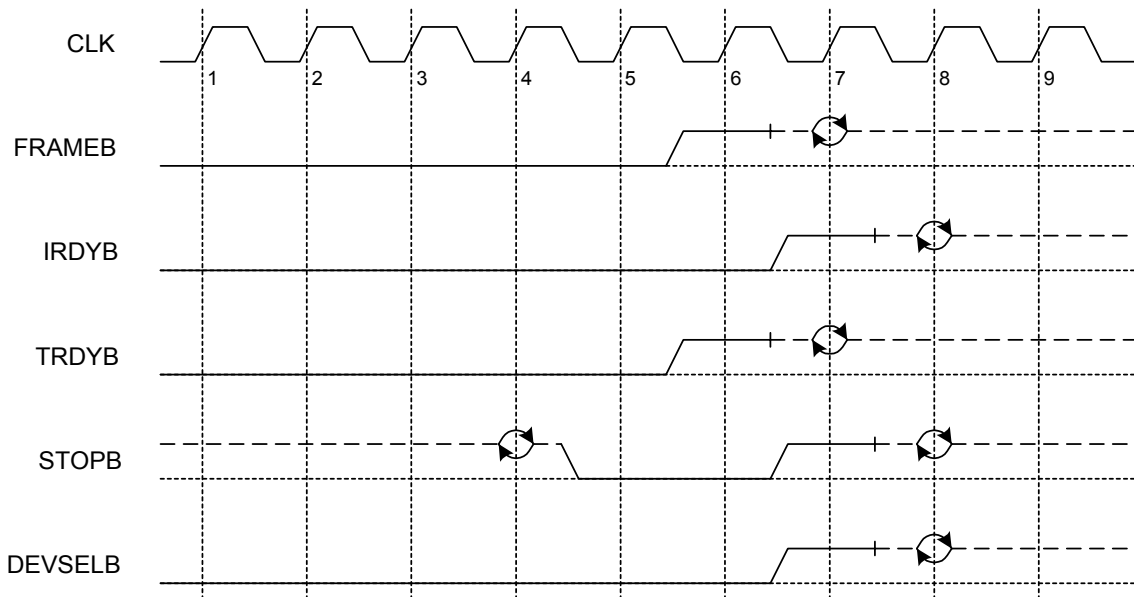

**Figure 18. Target Initiated Termination - Disconnect**

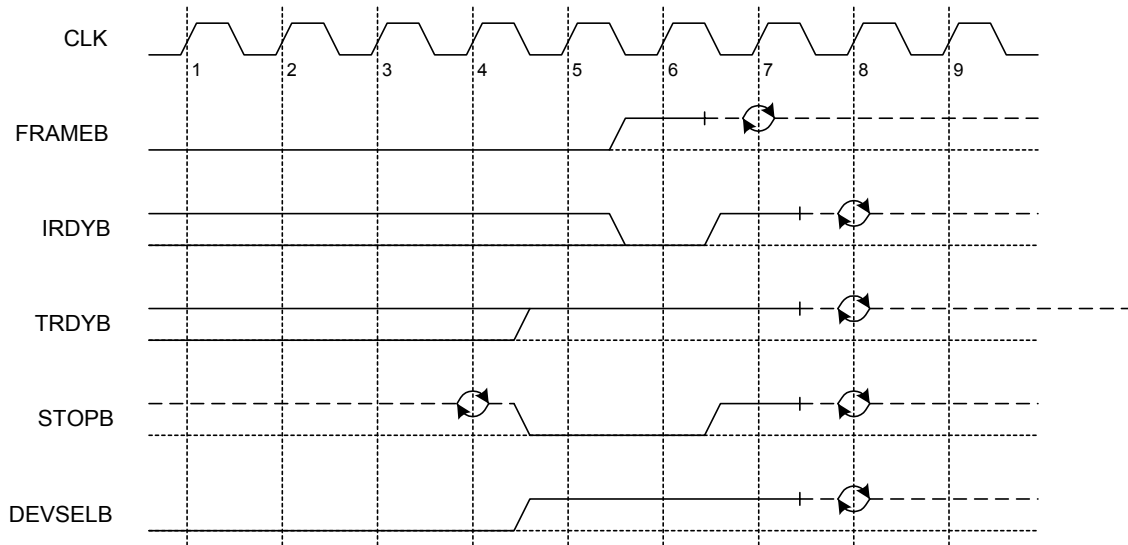

**Figure 19. Target Initiated Termination - Abort**

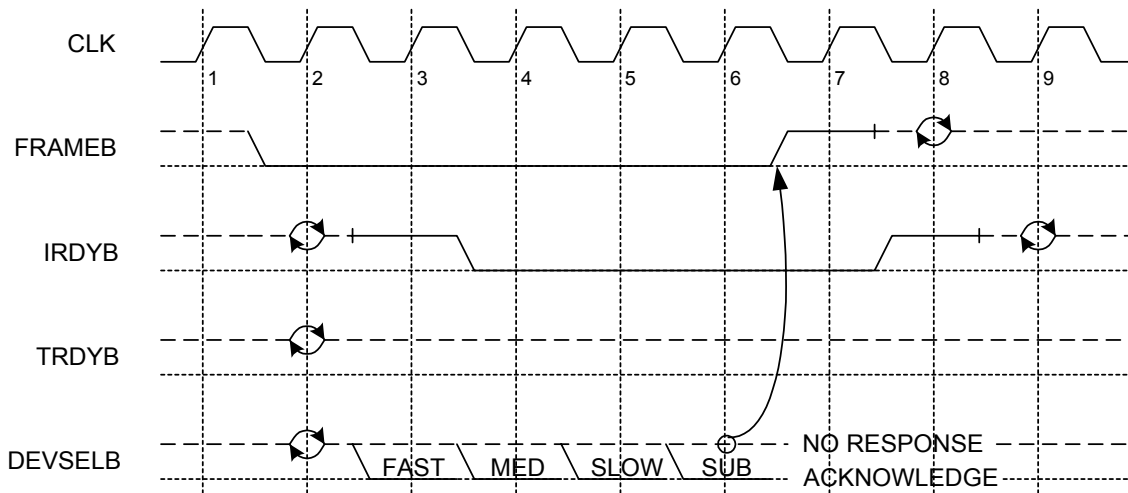

**Figure 20. Master Initiated Termination - Abort**

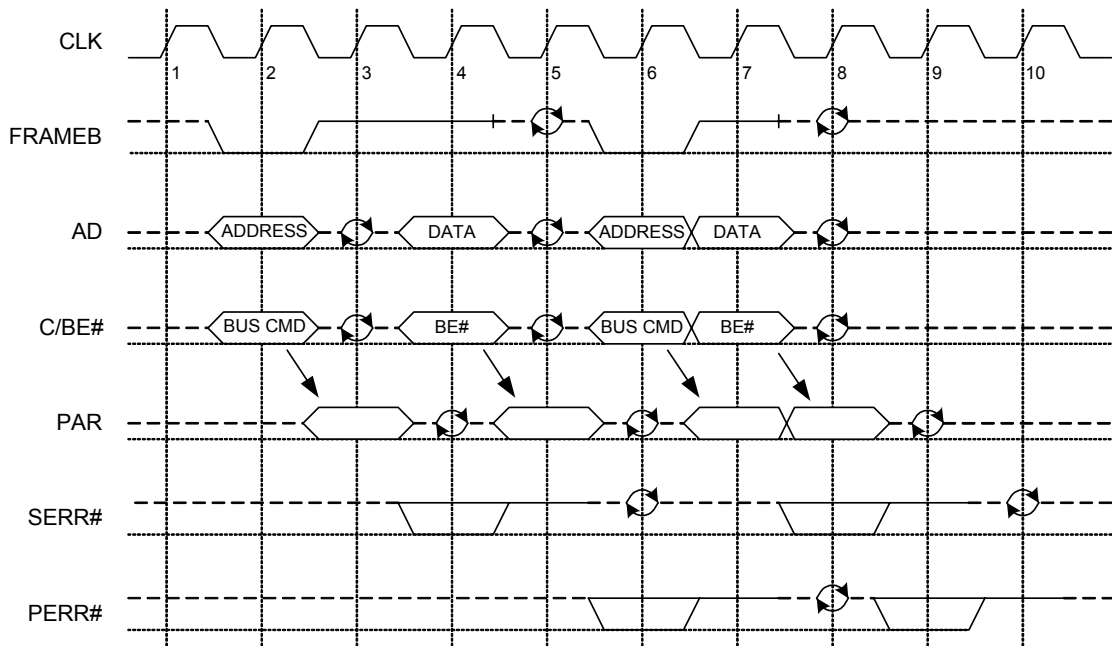

**Figure 21. Parity Operation – One Example**

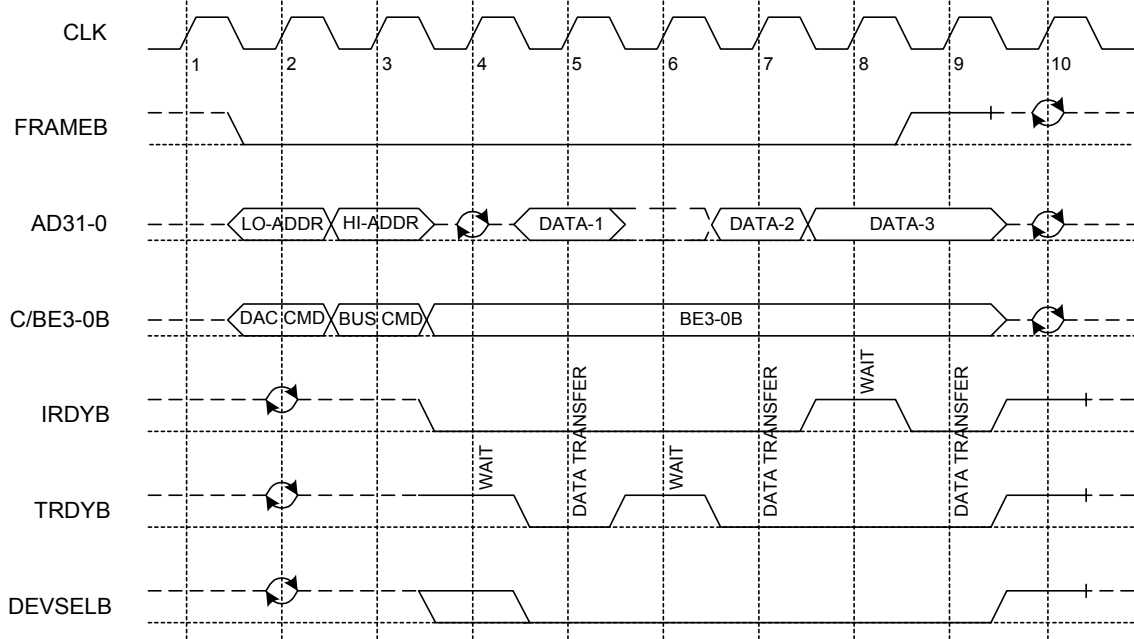

**Figure 22. Memory Read above 4GB (DAC, 64-bit address, 32-bit data)**

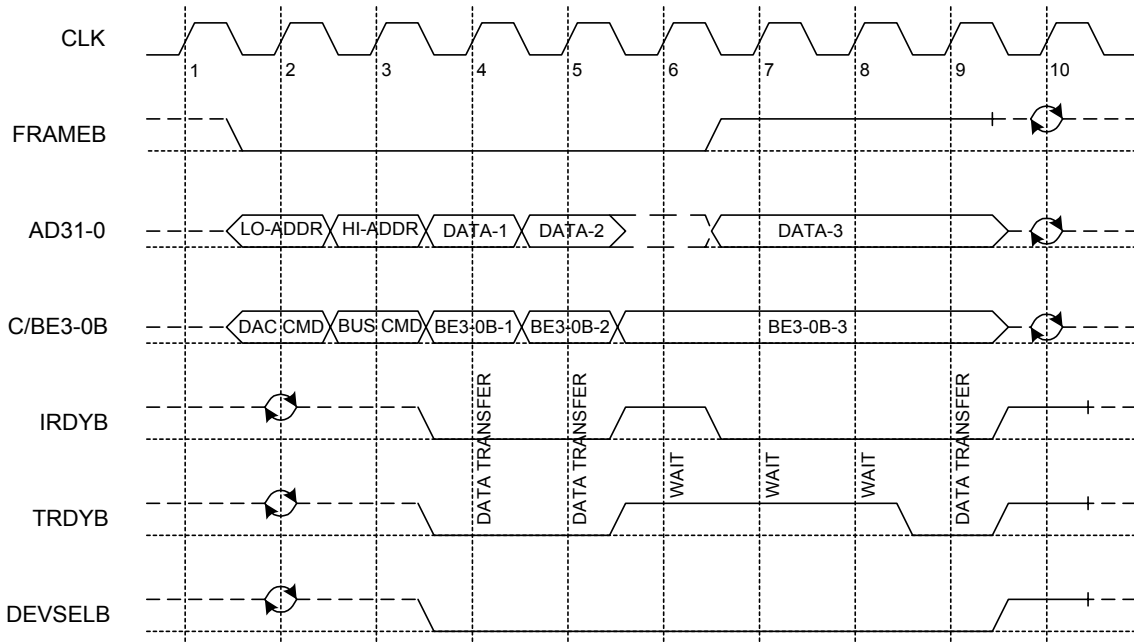
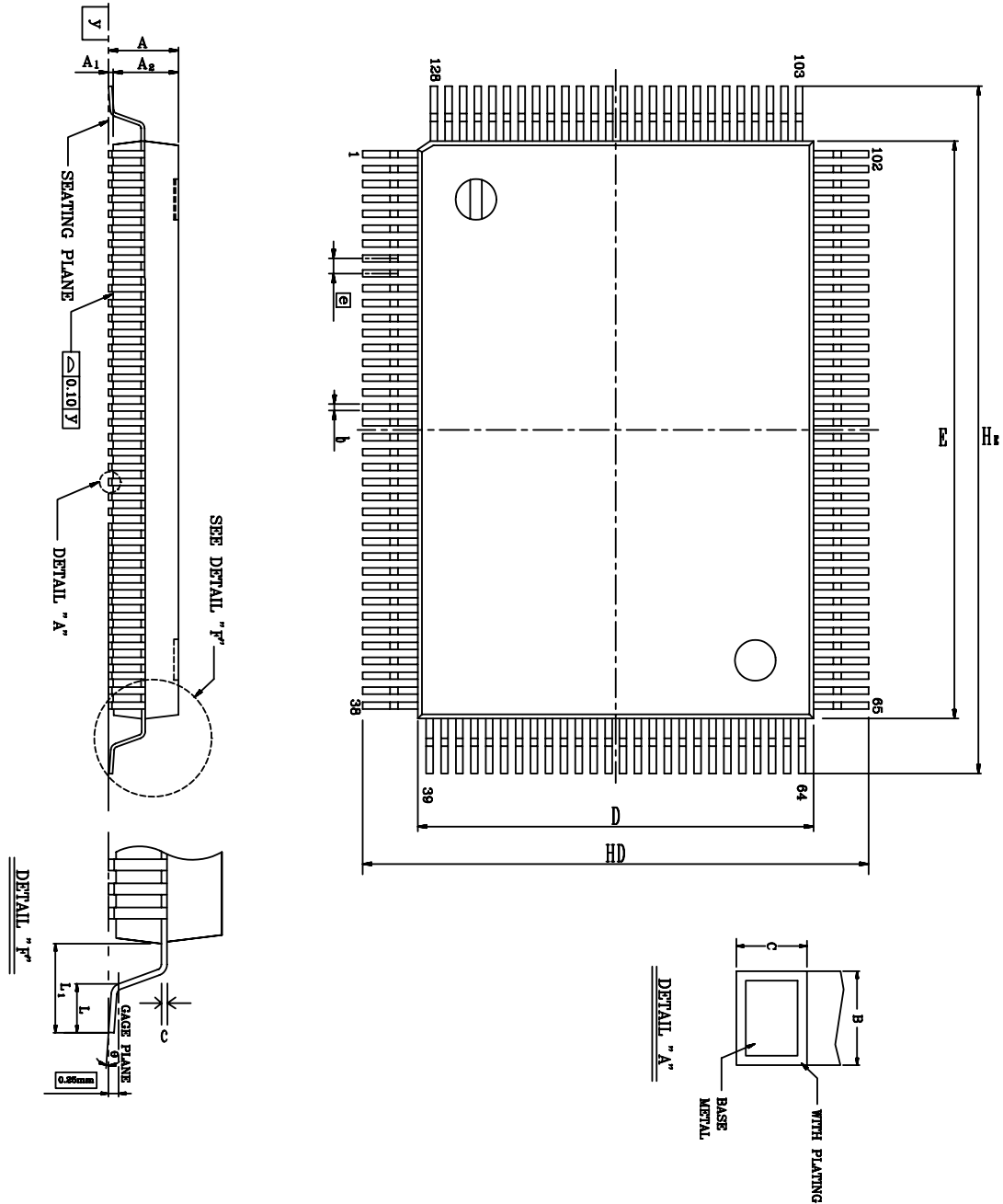

**Figure 23. Memory Write above 4GB (DAC, 64-bit address, 32-bit data)**



## 8. Mechanical Dimensions

### 8.1. 128-Pin QFP Mechanical Dimensions



See the Mechanical Dimensions notes on the next page.

## 8.2. Notes for 128-Pin QFP Dimensions

Symbol	Dimensions in inches			Dimensions in mm		
	Min	Typical	Max	Min	Typical	Max
<b>A</b>	-	-	0.134	-	-	3.40
<b>A1</b>	0.004	0.010	0.036	0.10	<b>0.25</b>	0.91
<b>A2</b>	0.102	0.112	0.122	2.60	<b>2.85</b>	3.10
<b>b</b>	0.005	0.009	0.013	0.12	<b>0.22</b>	0.32
<b>c</b>	0.002	0.006	0.010	0.05	<b>0.15</b>	0.25
<b>D</b>	0.541	0.551	0.561	13.75	<b>14.00</b>	14.25
<b>E</b>	0.778	0.787	0.797	19.75	<b>20.00</b>	20.25
<b>e</b>	0.020 BSC			<b>0.50 BSC</b>		
<b>HD</b>	0.665	0.677	0.689	16.90	<b>17.20</b>	17.50
<b>HE</b>	0.902	0.913	0.925	22.90	<b>23.20</b>	23.50
<b>L</b>	0.027	0.035	0.043	0.68	<b>0.88</b>	1.08
<b>L1</b>	0.053	0.063	0.073	1.35	<b>1.60</b>	1.85
<b>y</b>	-	-	0.004	-	-	0.10
<b>θ</b>	0°	-	12°	0°	-	12°

Notes:

1. Dimensions D & E do not include interlead flash.
2. Dimension b does not include dambar protrusion/intrusion.
3. Controlling dimension: Millimeter
4. General appearance spec. Should be based on final visual inspection.

TITLE: 128 QFP (14x20 mm ) PACKAGE OUTLINE			
-CU L/F, FOOTPRINT 3.2 mm			
LEADFRAME MATERIAL			
APPROVE		DOC. NO.	
		VERSION	
		PAGE	
CHECK		DWG NO.	Q128 - 1
		DATE	
REALTEK SEMICONDUCTOR CORP.			

## 9. Ordering Information

**Table 20. Ordering Information**

<b>Part Number</b>	<b>Package</b>	<b>Status</b>
RTL8169S-32	128-pin QFP	MP
RTL8169S-32-LF	128-pin QFP Lead (Pb)-Free	MP
RTL8169S-32-GR	128-pin QFP Green Package	MP

*Note: See page 3 for Lead (Pb)-Free/Green package identification.*

---

**Realtek Semiconductor Corp.****Headquarters**

No. 2, Industry East Road IX, Science-based  
Industrial Park, Hsinchu, 300, Taiwan, R.O.C.

Tel: 886-3-5780211 Fax: 886-3-5776047

[www.realtek.com.tw](http://www.realtek.com.tw)